

# HITACHI INVERTER

## J100 E5 SERIES

### INSTRUCTION MANUAL

Single phase input 200V class

Three phase input 400V class

**Power Drive Services Ltd.**

Unit 1, Victoria St. Ind. Est.

Leigh,

Lancs, WN7 5SE

Tel: 01942 260206

Fax: 01942 260525

Web:- [www.inverter.co.uk](http://www.inverter.co.uk)

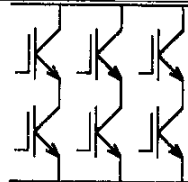

After reading this manual, keep it at hand for future reference.

**Hitachi, Ltd.**

Tokyo Japan

NB526X

# SAFETY

For the Best Results with J100 Series inverter, read this manual and all of the warning sign attached to the inverter carefully before installing and operating it, and follow the instructions exactly. Keep this manual handy for your quick reference.

## Definitions and Symbols

A safety instruction (message) is given with a hazard alert symbol and a signal word; **WARNING** or **CAUTION**. Each signal word has the following meaning throughout this manual.



This symbol means hazardous high voltage. It used to call your attention to items or operations that could be dangerous to your and other persons operating this equipment.

Read these message and follow these instructions carefully.



This is the "Safety Alert Symbol." This symbol is used to call your attention to items or operations that could be dangerous to your or other persons operating this equipment. Read these messages and follow these instructions carefully.



### **WARNING WARNING**

Indicates a potentially hazardous situation which, if not avoided, can result in serious injury or death.



### **CAUTION CAUTION**

Indicates a potentially hazardous situation which, if not avoided, can result in minor to moderate injury, or serious damage of product.

The matters described under **CAUTION** may, if not avoided, lead to serious results depending on the situation. Important matters are described in **CAUTION** (as well as **WARNING**), so be sure to observe them.

### **NOTE**

**NOTE:** Notes indicate an area or subject of special merit, emphasizing either the product's capabilities or common errors in operation or maintenance.



### **HAZARDOUS HIGH VOLTAGE**

Motor control equipment and electronic controllers are connected to hazardous line voltages. When servicing drives and electronic controllers, there might be exposed components with cases or protrusions at or above line potential. Extreme care should be taken to protect against shock.

Stand on an insulating pad and make it a habit to use only one hand when checking components. Always work with another person in case an emergency occurs. Disconnect power before checking controllers or performing maintenance. Be sure equipment is properly grounded. Wear safety glasses whenever working on an electronic controllers or rotating electrical equipment.

# SAFETY

For the Best Results with J100 Series inverter, read this manual and all of the warning sign attached to the inverter carefully before installing and operating it, and follow the instructions exactly. Keep this manual handy for your quick reference.

## Definitions and Symbols

A safety instruction (message) is given with a hazard alert symbol and a signal word; **WARNING** or **CAUTION**. Each signal word has the following meaning throughout this manual.



This symbol means hazardous high voltage. It used to call your attention to items or operations that could be dangerous to your and other persons operating this equipment.

Read these message and follow these instructions carefully.



This is the "Safety Alert Symbol." This symbol is used to call your attention to items or operations that could be dangerous to your or other persons operating this equipment. Read these messages and follow these instructions carefully.



### **WARNING WARNING**

Indicates a potentially hazardous situation which, if not avoided, can result in serious injury or death.



### **CAUTION CAUTION**

Indicates a potentially hazardous situation which, if not avoided, can result in minor to moderate injury, or serious damage of product.

The matters described under **CAUTION** may, if not avoided, lead to serious results depending on the situation. Important matters are described in **CAUTION** (as well as **WARNING**), so be sure to observe them.

### **NOTE**

**NOTE:** Notes indicate an area or subject of special merit, emphasizing either the product's capabilities or common errors in operation or maintenance.



### **HAZARDOUS HIGH VOLTAGE**

Motor control equipment and electronic controllers are connected to hazardous line voltages. When servicing drives and electronic controllers, there might be exposed components with cases or protrusions at or above line potential. Extreme care should be taken to protect against shock.

Stand on an insulating pad and make it a habit to use only one hand when checking components. Always work with another person in case an emergency occurs. Disconnect power before checking controllers or performing maintenance. Be sure equipment is properly grounded. Wear safety glasses whenever working on an electronic controllers or rotating electrical equipment.

**⚠ WARNING** This equipment has high leakage current and must be perminatly hard wired to earth via two independent cable.

**⚠ MOTORS**

- a) Class I motor must be connected to protective earth via low resistive path ( $< 0.1\Omega$ )
- b) Any motor used must be of suitable rating.
- c) Motors may have hazardous moving parts, in this event suitable protection must be provided.

**⚠ CAUTION**

Alarm connection may contain hazardous live voltage even when inverter is disconnected. In case of removing flont cover for maintenance or inspection, confirm that incoming power for alarm connection is surely disconnected.

**⚠ CAUTION**

Hazardous (main) terminals for any interconnection (motor, contact breaker, filter etc) must be inaccesible in end installation.

**⚠ CAUTION**

This equipment should be installed in an enclosure meeting requirements of IP4X(see EN60529). The end application must be in accordance with BS EN60204-1(with reference to manual page4-1 and 4-2,the diagram measurements to be suitably amended).

**⚠ CAUTION**

Cnnection to field wiring terminals must be reliably fixed having two independent means of support.Using terminal with cable support (figure below),or cable gland,cable clamp etc.

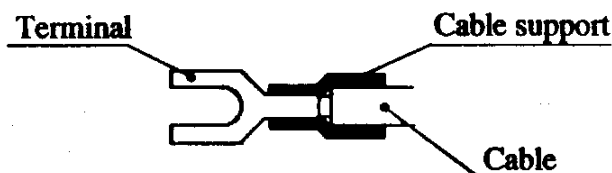

**⚠ CAUTION**

A double pole disconnection device must be fitted to the incoming mains supply close to theinverter. Additionally, a protection device meeting IEC947-1/IEC947-3 must be fitted at this point(Protection device data shown in page 5-8)

The above instructions.together wiht any other requirements highlighted in this manual.must be complied with for continued LVD compliance.

# PRECAUTIONS FOR EMC (Electro Magnetic Compatibility)

It is required to satisfy the EMC directive (89/336/EEC) when using J100 inverter in EU country. To satisfy EMC directive and to comply with standard, the followings should be kept.

## **⚠ WARNING:**

This equipment should be installed, adjusted and serviced by qualified personal familiar with construction and operation of the equipment and the hazards involved. Failure to observe this precaution could result in bodily injury.

### 1. Power supply to J100 inverter

- 1) Voltage fluctuation  $\pm 10\%$  or less.
- 2) Voltage unbalance  $\pm 3\%$  or less.
- 3) Frequency variation  $\pm 4\%$  or less.
- 4) Voltage distortion THD=10% or less.

### 2. Installation

- 1) Use filter designed for J100 inverter.
- 2) Install the filter and inverter into locked cabinet meeting requirements of IP4X.

### 3. Wiring

- 1) Shielded wire(screened cable) is required for motor wiring, and length is less than 50m.
- 2) Length is 20m to 50m, carrier frequency must be setting 5kHz.
- 3) Separate the main circuit wiring from signal/process circuit wiring.

### 4.Environment condition

When using a filter, keep the following condition.

#### ① Ambient temperature and carrier frequency

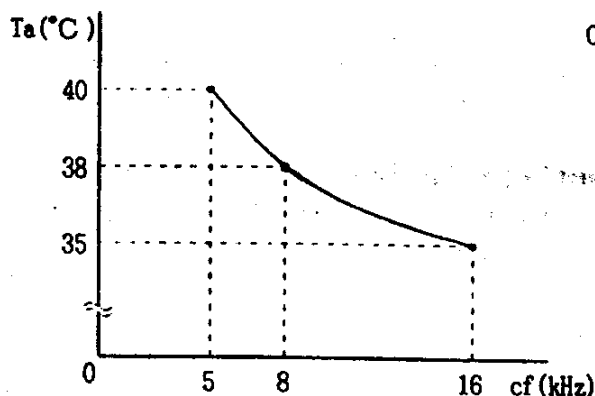

Carrier frequency can be changed by function A10, see page 8-18

② Humidity : 20 to 90% RH (no dew condensation)

③ Vibrations : 5.9 m/s<sup>2</sup> (0.6G) 10-55Hz

④ Location : 1000 meter or less altitude, indoor (no corrosive gas or dust)

### Revision History Table

No.	Revision Contents	The Date of Issue	Operation Manual No.

## TABLE OF CONTENTS

	Page
1. SAFETY PRECAUTIONS .....	1-1
2. INSPECTION UPON UNPACKING .....	2-1
3. APPEARANCE AND NAMES OF PARTS .....	3-1
4. INSTALLATION.....	4-1
5. WIRING .....	5-1
6. OPERATION .....	6-1
7. FUNCTION OF CONTROL CIRCUIT TERMINAL.....	7-1
8. OPERATION OF THE DIGITAL OPERATOR .....	8-1
9. PROTECTIVE FUNCTIONS .....	9-1
10. TROUBLESHOOTING .....	10-1
11. MAINTENANCE AND INSPECTION .....	11-1
12. STANDARD SPECIFICATIONS .....	12-1
13. FUNCTIONS WHEN USING THE OPTIONAL REMOTE OPERATOR.....	13-1
14. SERVICE .....	14-1
APPENDIX 1 J100 SERIES DATA SETTING VALUES (FOR THE DIGITAL OPERATOR) .....	A-1
APPENDIX 2 J100 SERIES DATA SETTING VALUES (FOR THE REMOTE OPERATOR) .....	A-4
APPENDIX 3 CAPACITOR LIFE CURVE.....	A-7

## 1. SAFETY PRECAUTIONS

### 1. Installation

#### CAUTION

- Be sure to install the unit on flame resistant material such as metal. .... p. 4-1  
Otherwise, there is a danger of fire.
- Be sure not to place anything inflammable in the vicinity. .... p. 4-1  
Otherwise, there is a danger of fire.
- Be sure not to let the foreign matter enter such as cut wire refuse, spatter from welding, iron refuse, wire, dust, etc. .... p. 4-1  
Otherwise, there is a danger of fire.
- Be sure to install it in a place which can bear the weight according to the specifications in the text (4. Installation). .... p. 4-1  
Otherwise, it may fall and there is a danger of injury.
- Be sure to install the unit on a perpendicular wall which is not subject to vibration. .... p. 4-1  
Otherwise, it may fall and there is a danger of injury.
- Be sure not to install and operate an inverter which is damaged or parts of which are missing. .... p. 4-1  
Otherwise, there is a danger of injury.
- Be sure to install it in a room which is not exposed to direct sunlight and is well ventilated. Avoid environments which tend to be high in temperature, high in humidity or to have dew condensation, as well as places with dust, corrosive gas, explosive gas, inflammable gas, grinding-fluid mist, salt damage, etc. .... p. 4-1  
Otherwise, there is a danger of fire.
- Be sure that the wall surface is a nonflammable material, such as steel plate. .... p. 4-2

### 2. Wiring

#### WARNING

- Be sure to ground the unit. .... p. 5-1  
Otherwise, there is a danger of electric shock and/or fire.
- Wiring work shall be carried out by electrical experts. .... p. 5-1  
Otherwise, there is a danger of electric shock and/or fire.
- Implement wiring after checking that the power supply is off. .... p. 5-1  
It might incur electric shock and/or fire.
- After installing the main body, carry out wiring. .... p. 5-1  
Otherwise, there is a danger of electric shock and/or injury.





### 3. Control and operation

#### WARNING

- Be sure to turn on the input power supply after mounting the surface cover. While being energized, be sure not to remove the cover. Otherwise, there is a danger of electric shock. .... p. 6-1
- Be sure not to operate the switches with wet hands. Otherwise, there is a danger of electric shock. .... p. 6-1
- While the inverter is energized, be sure not to touch the inverter terminals even during stoppage. Otherwise, there is a danger of electric shock. .... p. 6-1
- If the retry mode is selected, it may suddenly restart during the trip stop. Be sure not to approach the machine. (Be sure to design the machine so that personnel safety will be secured even if it restarts.) Otherwise, there is a danger of injury. .... p. 6-1, p. 8-24
- Even if the power supply is cut for a short period of time, it may restart operation after the power supply is recovered if the operation command is given. If it may incur danger to personnel, be sure to make a circuit so that it will not restart after power recovery. Otherwise, there is a danger of injury. .... p. 6-1
- The Stop Key is effective only when the function is set. Be sure to prepare the Key separately from the emergency stop. Otherwise, there is a danger of injury. .... p. 6-1
- After the operation command is given, if the alarm reset is conducted, it will restart suddenly. Be sure to set the alarm reset after checking the operation command is off. Otherwise, there is a danger of injury. .... p. 6-1 p. 7-13
- Be sure not to touch the inside of the energized inverter or to put a bar into it. Otherwise, there is a danger of electric shock and/or fire. .... p. 6-1
- When the power is turned on when the running command is on, the motor starts rotation and it is dangerous. Before turning the power on, confirm that the running command is not on. .... p. 7-4
- When the Stop key function is ineffective, pressing the Stop key does not cancel the stop and trip. Be sure to provide an emergency stop switch separately. When the operation command destination is a digital operator, this selection is ineffective. .... p. 8-27

 **CAUTION**

- Radiating fin and discharging resistor will have high temperature. .... p. 6-2  
Be sure not to touch them.  
Otherwise, there is a danger of getting burned.
- Low to high speed operation of the inverter can be easily set. Be sure ..... p. 6-2  
to operate it after checking the tolerance of the motor and machine.  
Otherwise, there is a danger of injury.
- If a motor is operated at a frequency higher than 60Hz, be sure to ..... p. 6-2  
check the speeds of the motor and the machine with each  
manufacturer, and after getting their consent, operate them.  
Otherwise, there is a danger of machine breakage.
- Check the following before and during the test run. .... p. 6-4  
Otherwise, there is a danger of machine breakage.
  - Was the short-cut bar between +1 and + removed?
  - Was the direction of the motor correct?
  - Was the inverter tripped during acceleration or deceleration?
  - Were the rpm and frequency meter correct?
  - Were there any abnormal motor vibrations or noise?

**4. Maintenance, inspection and part replacement**

 **WARNING**

- After a lapse of more than 5 minutes after turning off the input power ..... p. 11-1  
supply, perform the maintenance and inspection.  
Otherwise, there is a danger of electric shock.  
Before starting maintenance and inspection, be sure to check the  
charge lamp beside the control terminal is off.
- Make sure that only qualified persons will perform maintenance, ..... p. 11-1  
inspection and part replacement. (Before starting the work, remove  
metallic objects from your person (wristwatch, bracelet, etc.)  
(Be sure to use tools protected with insulation.)  
Otherwise, there is a danger of electric shock and/or injury.

 **WARNING**

- When removing connectors, never pull the wires. (Wires for cooling ..... p. 11-1  
fan and thermal relay)  
Otherwise, there is a danger of fire due to wire breakage and/or injury.

## 5. Others

### WARNING

- Never modify the unit.  
Otherwise, there is a danger of electric shock and/or injury.

### CAUTION

- Withstand voltage tests and insulation resistance tests (megger tests) are executed before the units are shipped, so that there is no need to conduct these tests before operation.

When conducting megger tests as a part of daily inspection, be sure that these tests are only executed between the main circuit and the ground. Do not execute megger tests on the control circuit.

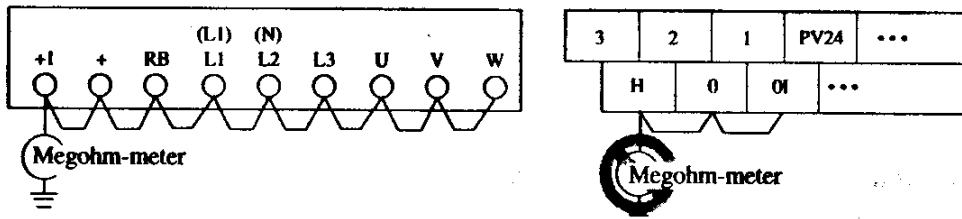

- Remove short wiring on the power PCB before conducting the test. And be sure to attach short wiring after the test. (for 400V class only)

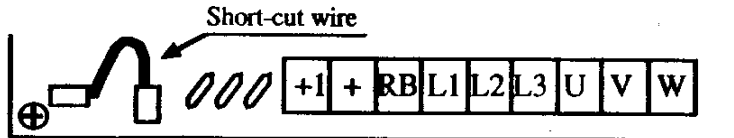

- Do not attach or remove wiring or connectors when power is applied. Also, do not check signals during operation.
- Do not stop operation by switching off the electromagnetic contactors on the primary or secondary sides of the inverter.

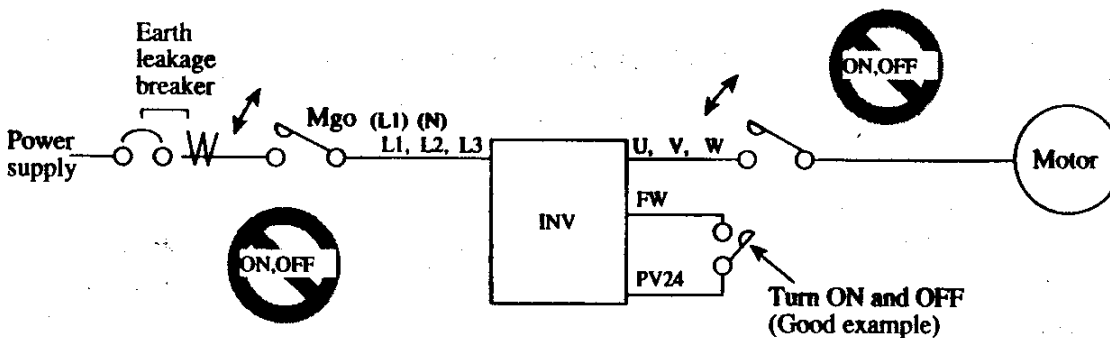

When there has been an instantaneous power failure, and if an operation instruction has been given, then the unit may restart operation after the power failure has ended. If there is a possibility that such an occurrence may harm humans, then install an electromagnetic contactor (Mgo) on the power supply side, so that the circuit does not allow automatic restarting after the power supply recovers. If the optional remote operator is used and the retry function has been selected, this will also cause automatic restarting when an operation instruction has been input, so please be careful.

**⚠ CAUTION**

- Do not insert leading power factor capacitors or surge absorbers between the output terminals of the inverter and the motor.

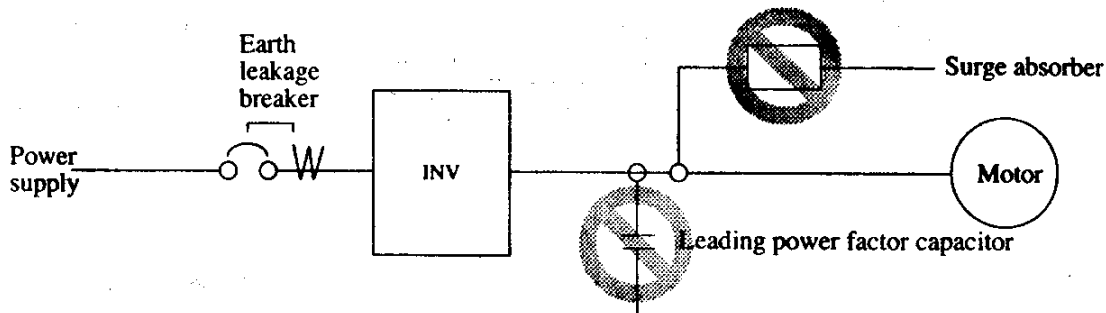

- Be sure to ground the grounding terminal,  $\oplus$ .
- When inspecting the unit, after turning the power supply off be sure to wait until the CHARGE lamp beside the control terminal is off before opening the cover.

(If the lamp is lit or still flickering, then the internal capacitor's residual voltage is still dangerous.)

- **MOTOR TERMINAL SURGE VOLTAGE SUPPRESSION FILTER (FOR THE 400 V CLASS)**

In a system using an inverter of the voltage control PWM system, a surge voltage caused by the cable constants such as the cable length (especially when the distance between the motor and inverter is 10 m or more) and cabling method may occur at the motor terminal.

A dedicated filter of the 400 V class for suppressing this surge voltage is available, Please order one.

- **PROTECTION AGAINST NOISE INTERFERENCE FROM INVERTER**

The inverter uses many semiconductor switching elements such as transistors and IGBTs. Thus, a radio set or measuring instrument located near the inverter is susceptible to noise interference.

To protect the instruments from erroneous operation due to noise interference, they should be installed well apart from the inverter. It is also effective to shield the whole inverter structure.

Addition of an EMI filter on the input side of the inverter also reduces the effect of noise from commercial power line on external devices.

Note that external dispersion of noise from the power line can be minimized by connecting an EMI filter on the primary side of inverter.

## ⚠ CAUTION

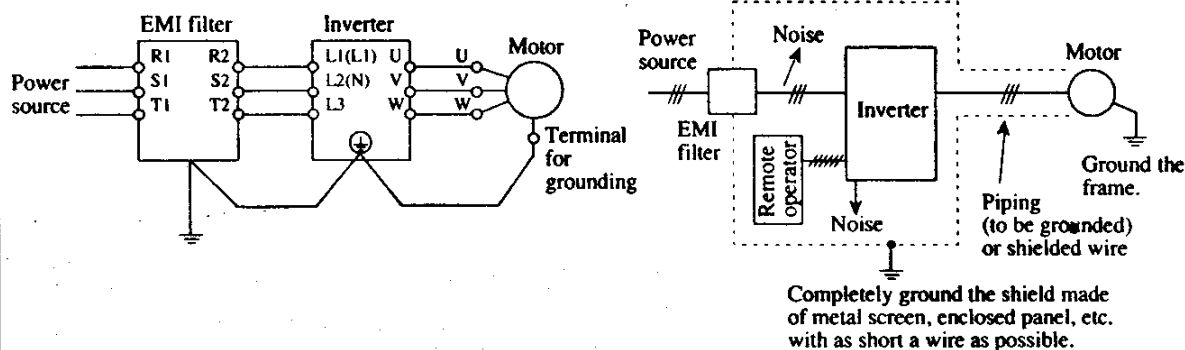

### ● EFFECTS OF DISTRIBUTOR LINES ON INVERTERS

In the cases below involving a general-purpose inverter, a large peak current flows on the power supply side, sometimes destroying the converter module. Where such situations are foreseen, or the paired equipment must be highly reliable, install an AC reactor between the power supply and the inverter.

- (A) The unbalance factor of the power supply is 3% or higher.
- (B) The power supply capacity is at least 10 times greater than the inverter capacity (and the power supply capacity, 500 kVA or more).
- (C) Abrupt power supply changes are expected.

Examples:

- (1) Several inverters are interconnected with a short bus.
- (2) A thyristor converter and an inverter are interconnected with a short bus.
- (3) An installed phase advance capacitor opens and closes.

In cases (A), (B) or (C), we recommend installing an AC reactor of 3% (in a voltage drop at rated current) with respect to the supply voltage on the power supply side.

- When occurring an EEPROM error ( **E B** ), be sure to confirm the setting value again.
- When setting b contact to the reverse command ([REV] terminal), the inverter state automatically. Do not set to b contact.

### GENERAL CAUTION

In all the illustrations in this manual, covers and safety devices are occasionally removed to describe the details. When the product is operated, make sure that the covers and safety devices are placed as they were specified originally and operate it according to the instruction manual.

## 2. INSPECTION UPON UNPACKING

Before installation and wiring, be sure to check the following:

- Make sure that there was no damage during transportation the unit.
- After unpacking the unit, make sure that the package contains one inverter and one operation manual
- Make sure that the product is the one you ordered by checking the specifications label on the front of the cover.

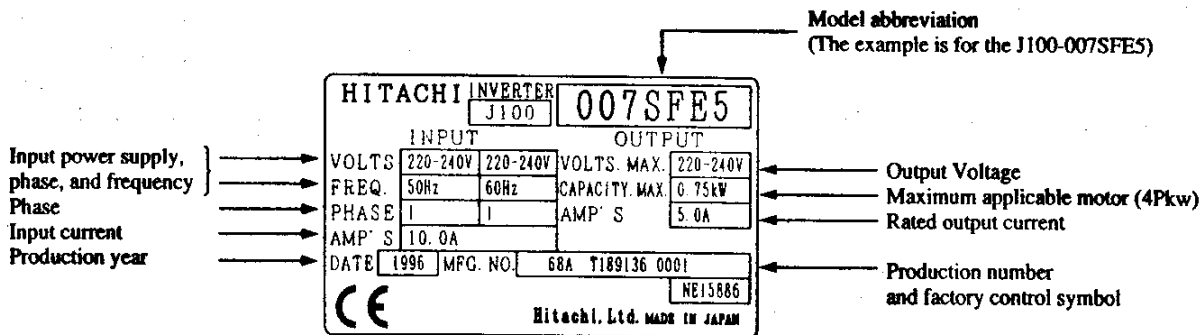

### Contents of Specifications Label

If you discover any problems, contact your sales agent immediately.

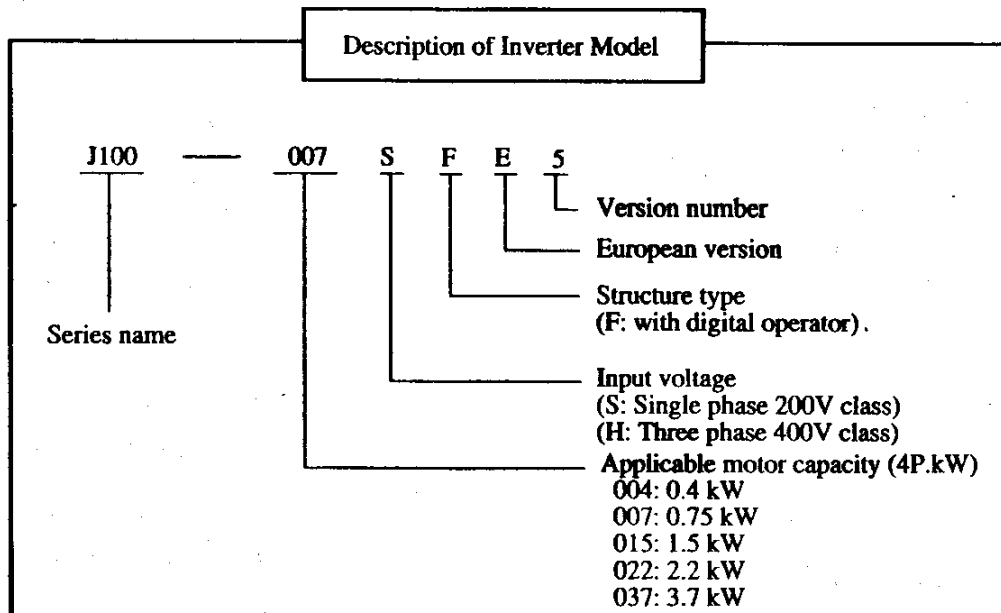

### 3. APPEARANCE AND NAMES OF PARTS

#### 3.1 Removing and reattaching the front cover

After removing the screws for attaching the front cover, the cover can be removed as shown below:

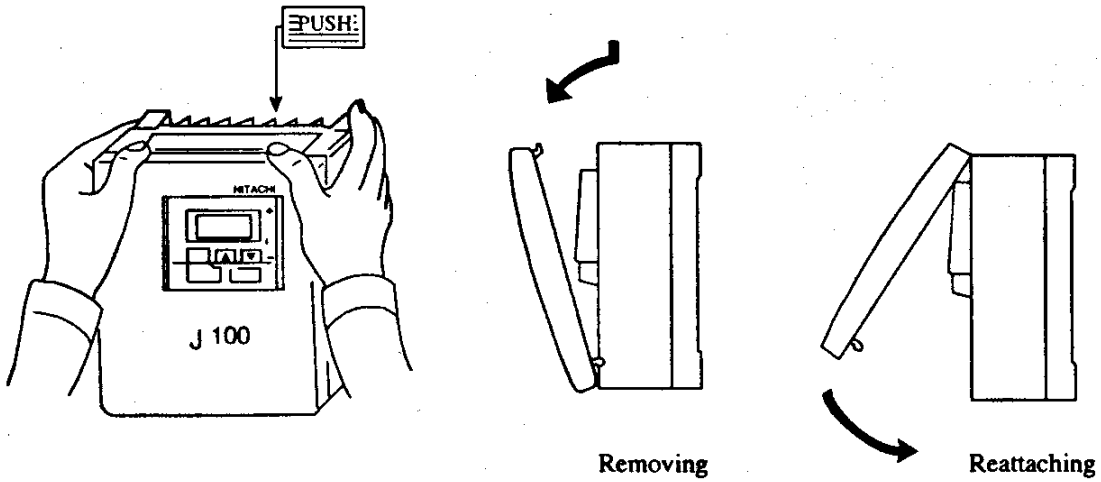

#### 3.2 Names of parts

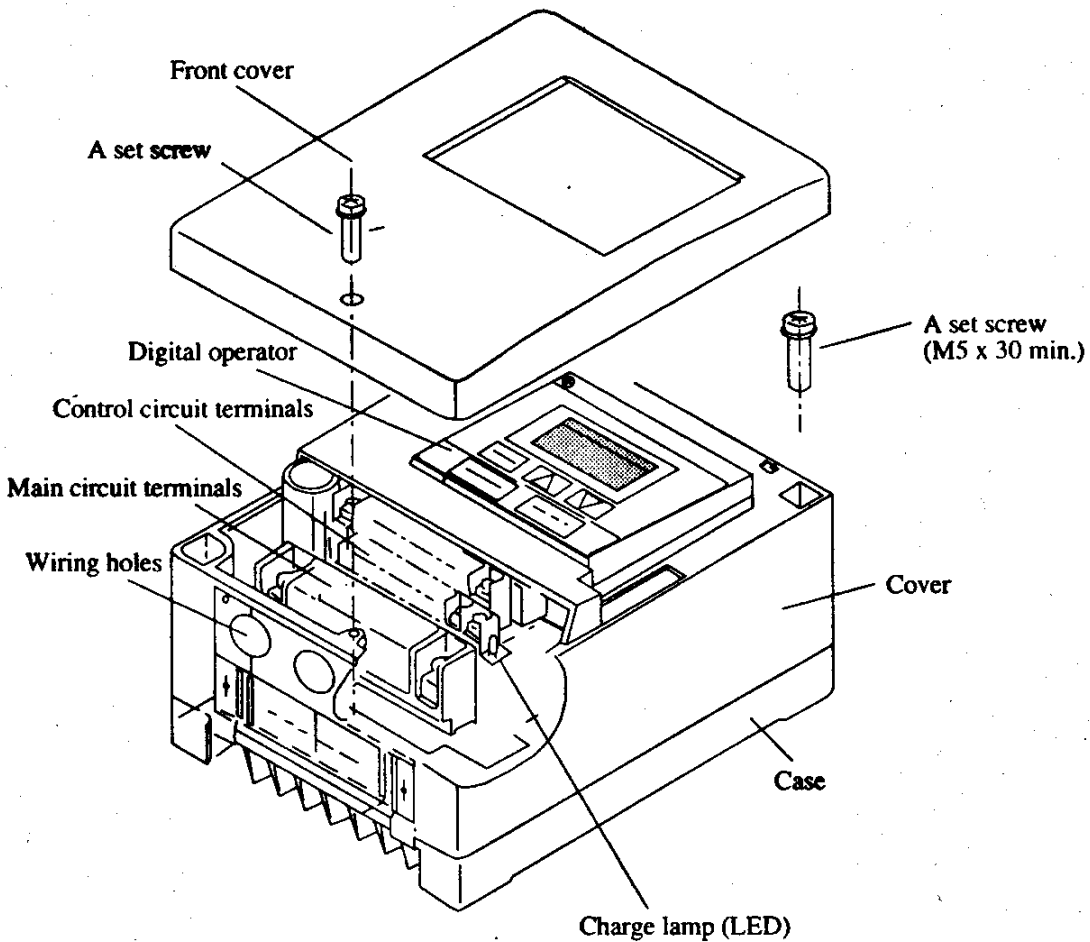



## 4. INSTALLATION

### CAUTION

- Be sure to install the unit on flame resistant material such as metal. Otherwise, there is a danger of fire.
- Be sure not to place anything inflammable in the vicinity. Otherwise, there is a danger of fire.
- Be sure not to let the foreign matter enter such as cut wire refuse, spatter from welding, iron refuse, wire, dust, etc. Otherwise, there is a danger of fire.
- Be sure to install it in a place which can bear the weight according to the specifications in the text (4. Installation). Otherwise, it may fall and there is a danger of injury.
- Be sure to install the unit on a perpendicular wall which is not subject to vibration. Otherwise, it may fall and there is a danger of injury.
- Be sure not to install and operate an inverter which is damaged or parts of which are missing. Otherwise, there is a danger of injury.
- Be sure to install it in a room which is not exposed to direct sunlight and is well ventilated. Avoid environments which tend to be high in temperature, high in humidity or to have dew condensation, as well as places with dust, corrosive gas, explosive gas, inflammable gas, grinding-fluid mist, salt damage, etc. Otherwise, there is a danger of fire.

For cooling purposes, be sure that the inverter is installed vertically. In addition, be sure that it is separated from other components and walls. If foreign matter is introduced into the interior of the inverter, this may cause malfunctions, so make sure that no foreign matter can enter it.

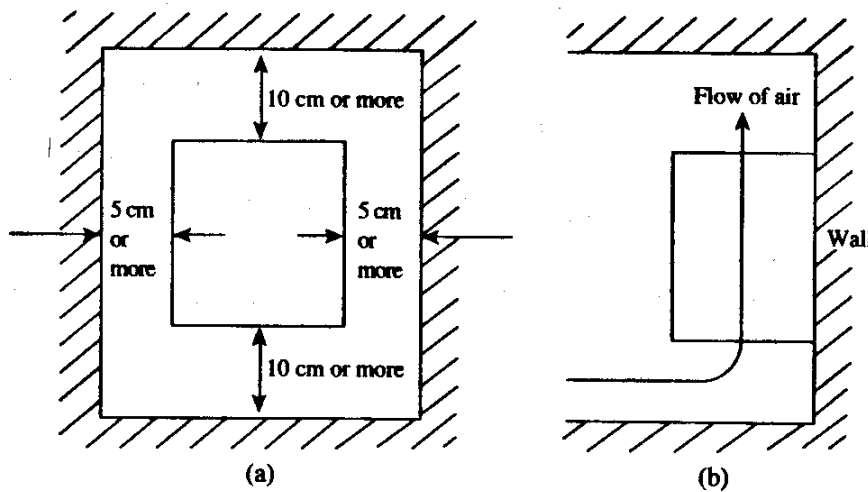

**NOTE:** Install the inverter vertically.  
Do not install it on the floor or horizontally.

**CAUTION**  
Be sure that the wall surface is a nonflammable material, such as steel plate.

During wiring or other work, do not allow any wire scraps, welding fragments, iron scraps, dust, etc. to enter into the inverter, therefore be sure to cover the top of the inverter before working.

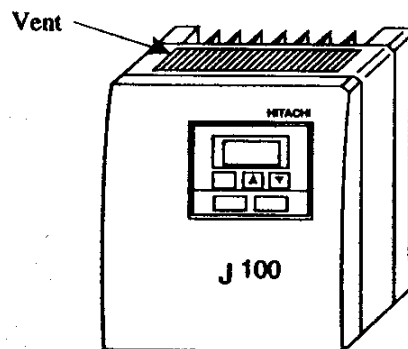

**CAUTION** Be sure to check the ambient temperature (-10 to 40°C).

**NOTE 1**

The higher the ambient temperature inside the inverter, the shorter its life will be. If a heat generating unit is used near the inverter, try to keep it as far away as possible. Also, when installing the inverter in a box, be sure to carefully consider ventilation and the dimensions.

See the mounting dimension diagram for details (PAGE 12-6).

**CAUTION** Be sure to install the inverter in a locked enclosure meeting the requirements of IP4X (see EN60529).

**NOTE 1:** For EMC directive and Low Voltage directive, do not remove the front cover.

**NOTE 2:** The end application must be in accordance with BS EN60204-1.

## 5. WIRING



### WARNING

- Be sure to ground the unit.  
Otherwise, there is a danger of electric shock and/or fire.
- Wiring work shall be carried out by electrical experts.  
Otherwise, there is a danger of electric shock and/or fire.
- Implement wiring after checking that the power supply is off.  
It might incur electric shock and/or fire.
- After installing the main body, carry out wiring.  
Otherwise, there is a danger of electric shock and/or injury.

**⚠ CAUTION**

- Make sure that the input voltage is:  
Single phase 220 to 240 V 50/60 Hz  
Three phase 380 to 415 V/50 Hz, 400 to 460 V/60 Hz
- Be sure not to input a single phase to a 3 phase type.  
Otherwise, there is a danger of fire.
- Be sure not to connect AC power supply to the output terminals (U, V, W).  
Otherwise, there is a danger of injury and/or fire.

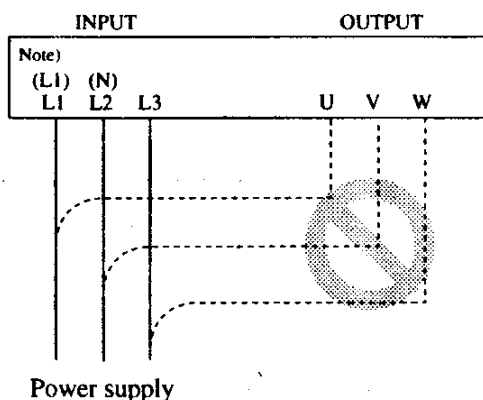

Note: L1, N: Single phase 220 to 240V 50/60 Hz  
L1, L2, L3: Three phase 380 to 415V/50 Hz  
400 to 460V/60 Hz

- Fasten the screws with the specified fastening torque. Check so that there is no loosening of screws.  
Otherwise, there is a danger of fire.
- Remarks for using earth leakage circuit breakers in the mains supply:  
Frequency inverters with CE-filters (RFI-filter) and screened motor cables have a higher leakage current against earth. Especially in the moment of switching on this can cause unintentional triggerings of earth leakage circuit breakers. Because of the rectifier on the input side of the inverter there is the possibility to stall the switch-off function through amounts of DC-current. The following should be observed:  
Only short time-invariant and pulse current-sensitive earth leakage circuit breakers with higher trigger current should be used.  
Other components should be secured with separate earth leakage circuit breakers.  
Earth leakage circuit breakers in front of an inverter are not an absolute protection against direct touching.
- Be sure to set the fuse(s) (the same phase as the main power supply) in the operation circuit.  
Otherwise, there is a danger of fire.
- As for motor leads, earth leakage breakers and electromagnetic contactors, be sure to use the equivalent ones with the specified capacity (rated).  
Otherwise, there is a danger of fire.
- Double pole disconnection device must be fitted to the incoming mains supply close to the inverter. And protection device meeting IEC947-1/IEC947-3 must be fitted at this point.
- Connection to wiring terminal must be reliably fixed with two means of support.

## 5.1 Wiring the power supply and motor

The terminal board will be exposed when the front cover is removed. Wire the inverter in this state.

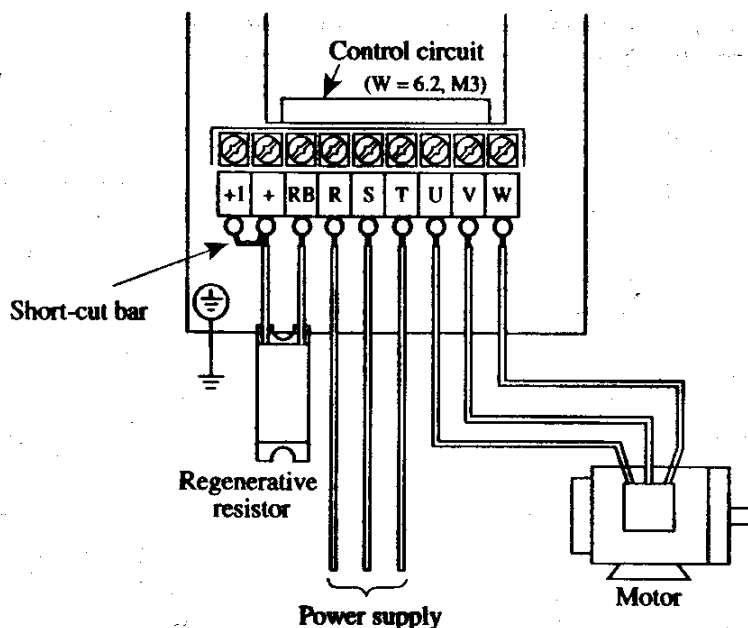

- The inverter will be damaged if the power supply is connected to the motor terminals U, V and W, so be sure not to make any mistakes.
- If multiple motors are to be connected, be sure to attach a thermal relay to each motor.
- See the page 5-8 on the terminal dimensions.
- Make sure that the wiring is:  
Single phase 220 to 240 V/50 Hz, 60 Hz ..... (L1), (N) terminals.  
Three phase 380 to 415 V/50Hz, 400 to 460 V/60 Hz ..... L1, L2, L3.
- Make sure that the short-cut bar which has been attached in advance between terminals +1 and + is not removed except when the DC Reactor is being mounted.

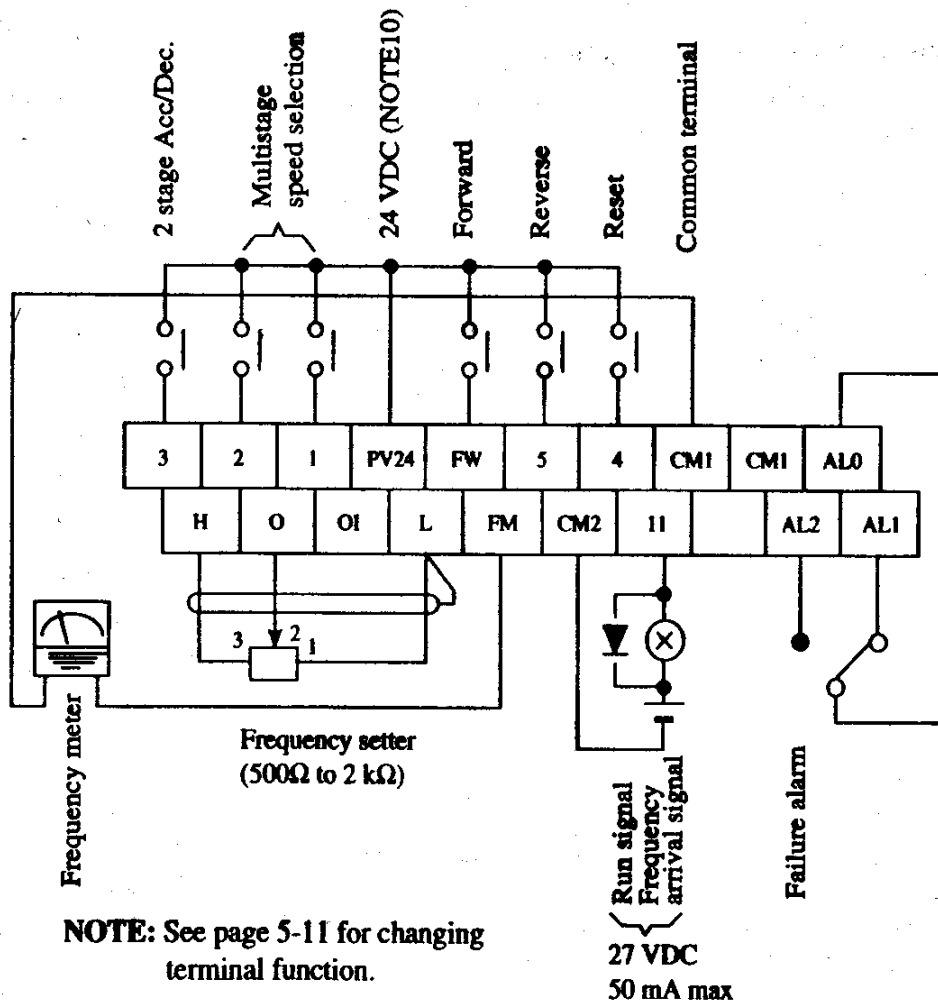

**Control circuit terminal diagram**

**NOTE 1:** When changing the power supply of the motor between the inverter and commercial power, be sure to install mechanically interlocked switches Mg1 and Mg2.

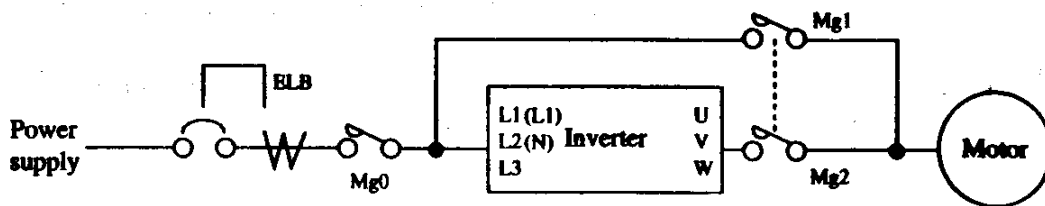

**NOTE 2:** Install an earth leakage breaker at the input of the inverter. (Select an earth leakage breaker whose sensitive current level is raised in high frequency range.)  
When the cable between the inverter and motor is more than 10 m long, the thermal relay may malfunction due to high-frequency waves. To prevent this, install an AC reactor on the output side of the inverter or use a current sensor rather than a thermal relay.

**NOTE 3:** Be sure that the specified grounding is carried out. Be sure to separate the unit's grounding pole from those of other heavy electric machinery, and avoid using common grounding poles.

If multiple inverters are used, make sure that the grounding connections do not create a loop.

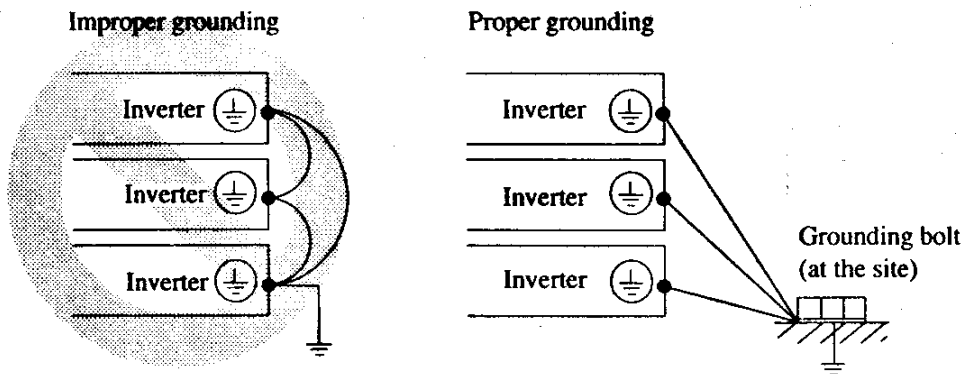

**NOTE 4:** When a frequency arrival signal is used, be sure to install a surge absorbing diode in parallel with the relay. Otherwise, the surge voltage created when the relay goes ON or OFF may damage the AR output circuit.

**NOTE 5:** Use a twisted and shielded wire for the signal line, and cut the shielded covering as shown in the diagram below. Make sure that the length of the signal line is 20 meters or less. If the line must be longer than 20 meters, please use a VX application control device RCD-A (remote control device) or CVD-E (insulated signal converter).

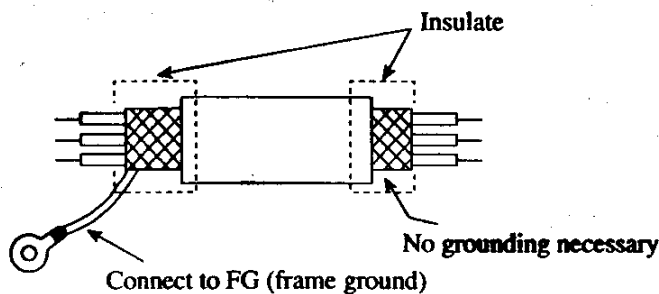

**NOTE 6:** When the frequency setting signal is turned on and off with a contact, use a relay which will not cause contact malfunctions, even with the extremely weak currents and voltages, such as crossbar twin contacts, etc.

**NOTE 7:** Use relays which do not have contact defects at 24 V DC, 3 mA for the other terminals.

**NOTE 8:** Separate the main circuit wiring from the relay control circuit wiring. If they must cross, be sure that they cross at a right angle.

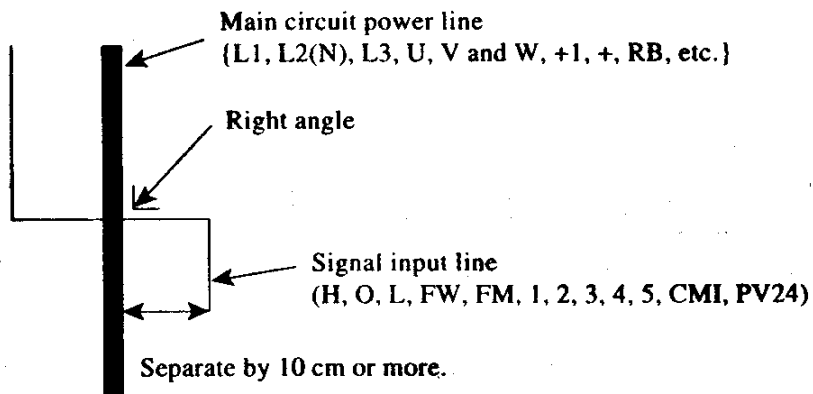

**NOTE 9:** Insulate frequency analog command input terminal L from the common terminal for peripheral devices such as the programmable controller.

**NOTE10:** Do not short circuit the terminals PV24 and CM1 by mistake.  
The control power supply may cause a failure.

**NOTE11:** Do not short-circuit the terminals H and L.  
The control power supply may cause a failure.



## Connection to the Programmable Controller

(1) When the internal interface power source is used

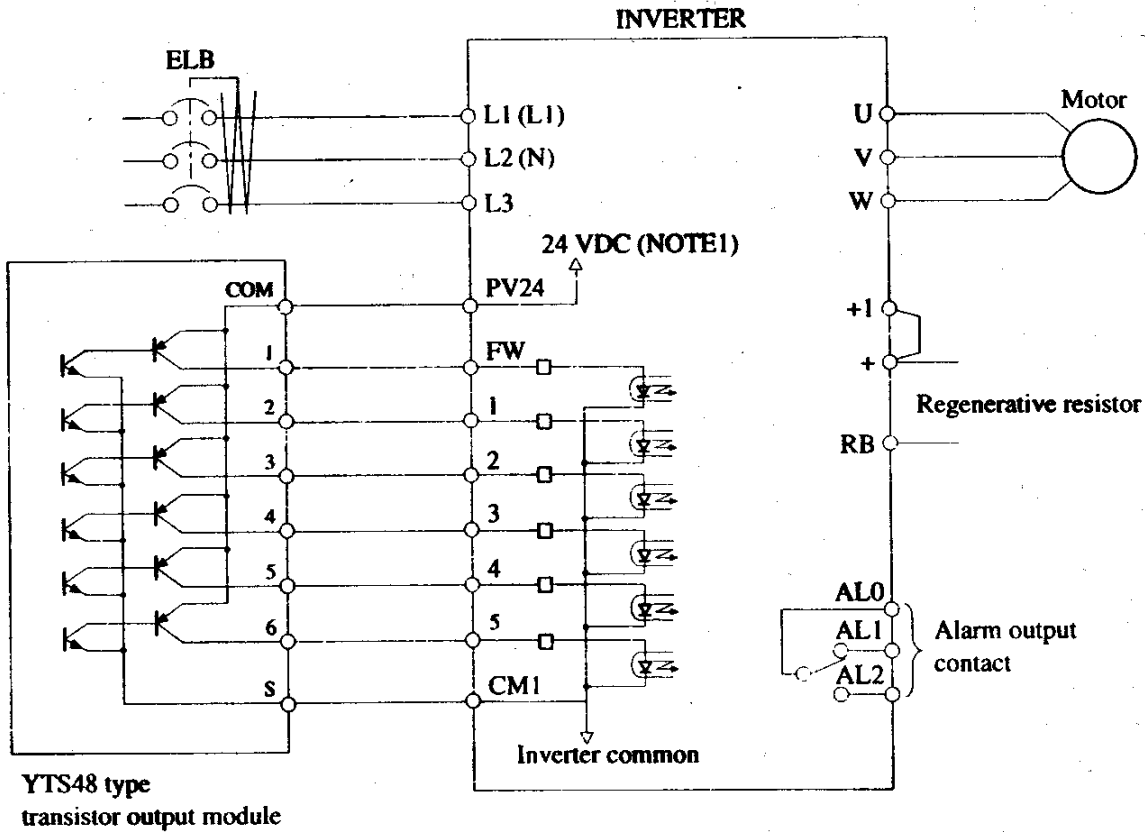

(2) When the external interface power source is used

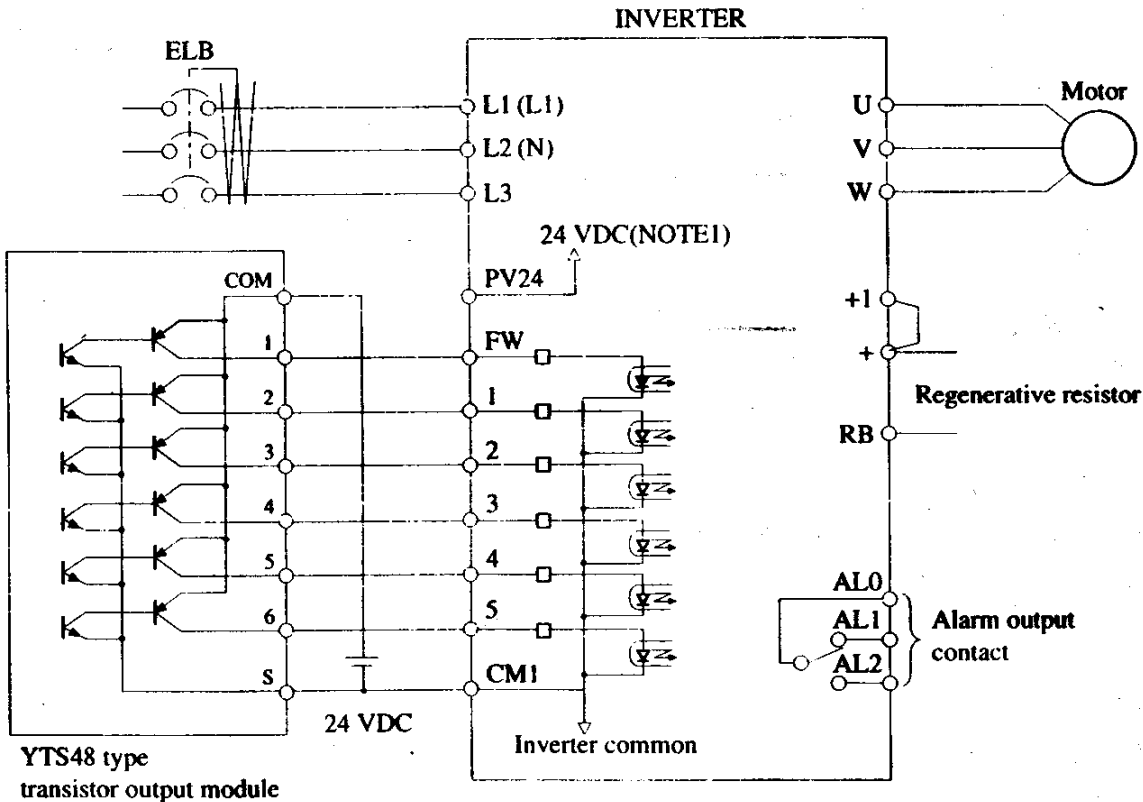

**NOTE 1:** Do not short circuit the terminals PV24 and CM1 by mistake.  
The control power supply may cause a failure.

## 5.2 Wiring Equipment, Options

**CAUTION:** Provide the wiring equipment in accordance with the safety codes required by jurisdictional authorities.

The table below is an example selected out of the Hitachi's standard distribution equipment.

If specified in the standard or laws and regulations, follow their instructions.

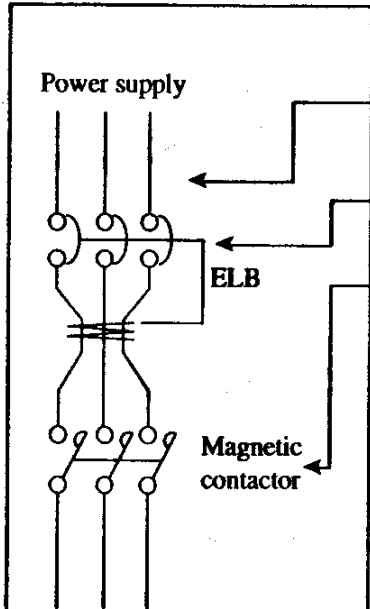

Motor output (kW)	Inverter model	Wiring		Applicable equipment	
		Power lines	Signal lines	Earth leakage breaker (ELB)	Electromagnetic contactor
0.4	J100-004SFE5	1.25 mm <sup>2</sup>	(*) 0.75 mm <sup>2</sup> Shielded wire	EX30(10A)	H20
0.75	J100-007SFE5	2 mm <sup>2</sup>		EX30(15A)	H20
1.5	J100-015SFE5	2 mm <sup>2</sup>		EX30(20A)	H20
2.2	J100-022SFE5	2 mm <sup>2</sup>		EX30(30A)	H20
1.5	J100-015HFE5	2 mm <sup>2</sup>		EX30(10A)	H10C
2.2	J100-022HFE5	2 mm <sup>2</sup>		EX30(15A)	H20
3.7	J100-037HFE5	2 mm <sup>2</sup>		EX30(15A)	H20

**NOTE 1:** The applicable equipment is for a Hitachi standard four pole squirrel-cage motor.

**NOTE 2:** Be sure to consider the capacity of the circuit breaker to be used.

**NOTE 3:** Be sure to use bigger wires for power lines if the distance exceeds 20 m.

**NOTE 4:** Install an earth leakage breaker meeting requirements of IEC947-1/IEC94 at the input.

(\*) Use 1.25 mm<sup>2</sup> wire for the alarm signal wire.

Classify the detective current of the earth leakage breaker depending on the total distance between the inverter and the motor.

l	Detective current (mA)
100 m and less	30
300 m and less	100
600 m and less	200

**NOTE 1:** When using CV wire and metal tube, the leakage current is around 30 mA/km.

**NOTE 2:** When using CV wire and metal tube, the leakage current becomes eight times because IV wires have a high dielectric constant.

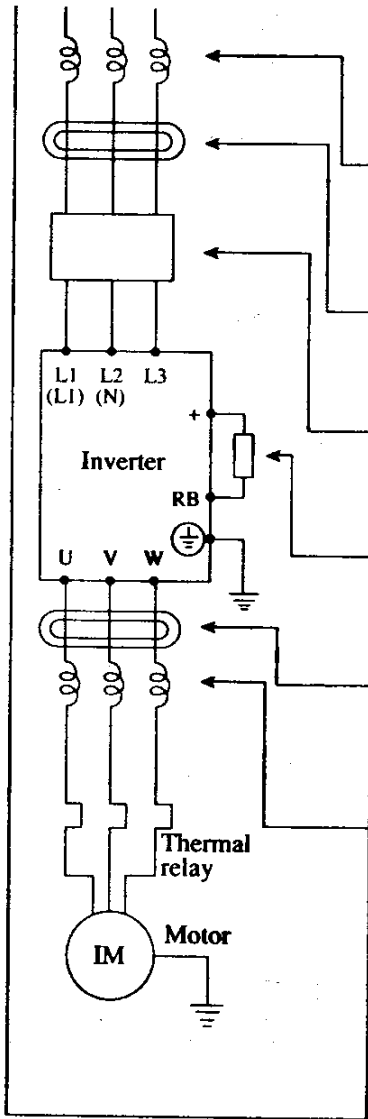

Part description	Function
AC reactor for improving the power factor (ALI-□□H)	This part is used when the unbalance voltage ratio is 3% or more and power supply is 500 kVA or more, and there is a rapid change in the power supply. It also improves the power factor.
Radio noise filter (Zero phase reactor) (ZCL-A)	Using the inverter may cause noise on the peripheral equipment through the power lines. This part reduces noise.
EMI filter for inverter (IFJ100-□□)	This part reduces common noise generated between the power supply and the ground, as well as normal noise. Put it in the primary side of inverter. <b>NOTE 1</b>
Regenerative resistor (RB□□□-□)	This part is used for applications that needs to increase the brake torque of the inverter or to frequently turn on and off and to run high inertia load.
Radio noise filter (Zero phase reactor) (ZCL-A)	This part reduces noise generated at the output of the inverter. (It is possible to use for both input and output.)
AC reactor for preventing thermal relay malfunction and reducing vibration (ACL-L-□□ ACL-H-□□)	Running motors with the inverter generates vibration greater than that with commercial power supply. This part installed between the inverter and motor reduces torque ripple. When the cable between the inverter and moter is too long, this part also prevents the thermal relay from malfunctioning.

**NOTE 1:** IFJ100 series filter is required for EMC directive, but others are not for this purpose.  
Reactor and others of the above table except EMI filter are for general use for noise reduction.

### 5.3 Terminal

#### Main circuit terminal

Single phase 220 to 240 V 50/60 Hz

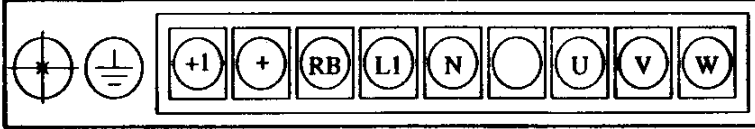

Three phase 380 to 415 V 50 Hz/400 to 460 V 60 Hz

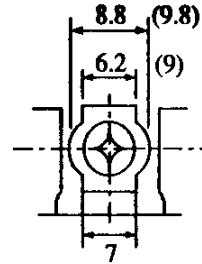
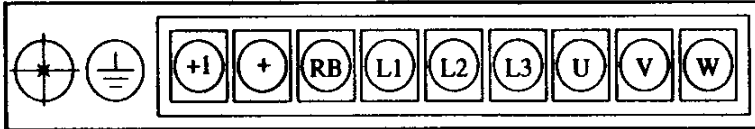

Main circuit terminal

Note: Value inside ( ) for 015 and 022SFE5, 015 to 037HFE5

Control circuit terminal

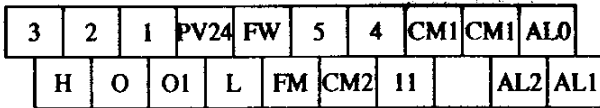

	Screw diameter	Width (mm)
Main circuit	M4	8.8 (9.8)
Control circuit	M3	6.2 (9)
Grounding	M4	—

Dimension

#### Main circuit

Terminal symbol	Terminal description	Function
L1 L2 L3 (L1), (N)	Main power	Connect the power supply
U, V, W	Inverter output	Connect the motor
+1	External DC Reactor	Usually the short-cut bar is attached between terminals +1 and +. When the DC Reactor is to be connected, be sure to remove the short-cut bar.
+,RB	External regenerative resistor	Connect a regenerative resistor (option)
⊥	Ground	Ground (connect grounding to avoid electric shock)

Make sure that the short-cut bar attached between +1 and + is not removed except when the DC Reactor is to be mounted.

#### Tightening torque

Screw	Tightening torque
M3	0.5 N·m (max. 0.7 N·m)
M4	0.5 N·m (max. 0.7 N·m)

Control circuit

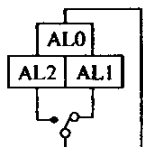
	Terminal symbol	Terminal description and function		Initial setting	Remarks	
Input signal	FW	Forward operation			Dry contact Close: ON (run) Open: OFF (stop)  Min. ON time: 12 ms or more	
	5	Intelligent input terminals 1 to 5		Reverse running command		
	4	Reverse running command	Initialization (Note 1)	USP function		Reset input (Note 2)
	3	Multistage speed (First stage)	2nd setting function	Reset		2 stage acc./dec. time
	2	Multistage speed (Second stage)	2 stage acc./dec. time	Terminal software lock (Note 3)		Multistage speed (Second stage)
	1	Multistage speed (Third stage)	Free run stop			Multistage speed (First stage)
			External DC Damping one of the above is selected.	External trip		
	PV24	Common for input signals			Output current: max. 100 mA	
Monitor signal	FM	Analog frequency monitor/Digital frequency monitor/Analog output current monitor		Analog frequency monitor		
	CM1	Common for monitor				
Frequency command input	H	Power supply for frequency command			5 VDC	
	O	Voltage frequency command			0-5 VDC (nominal) 0-10 VDC (nominal) (Input impedance 30 kΩ)	
	OI	Current frequency command			DC 4-20 mA (nominal) Input impedance 250Ω	
	L	Common for frequency command				
Output signal	11	Intelligent output terminal One of frequency arrival signal, RUN signal, and Overload advance notice signal is selected.		Frequency arrival signal	27 VDC 50 mA max	
	CM2	Common for output				
Fault alarm output	AL0		Normal: AL0-AL1 close Abnormal, Power off: AL0-AL1 open (Initial setting)	Contact rating 250 VAC 2.5 A (Resistor load) 0.2 A (cosφ=0.4) 30 VDC 3.0 A (Resistor load) 0.7 A (cosφ=0.4)	(Min 100 VAC) 10 mA 5 VDC 100 mA	
	AL1					
	AL2					

NOTE 1: USP: Prevention function of restart upon power on.

NOTE 2: The reset terminal cannot be changed from "a contact" (NO) to "b contact" (NC).

NOTE 3: When the software is to be locked by the terminal 3 in the same way as with the J100E2 series, it is necessary to switch the terminal. (See page 7.14.)

## 6. OPERATION

### 6.1 Before Starting Operation

Prior to the test run, check the following.

#### WARNING

- Be sure to turn on the input power supply after mounting the surface cover. While being energized, be sure not to remove the cover. Otherwise, there is a danger of electric shock.
- Be sure not to operate the switches with wet hands. Otherwise, there is a danger of electric shock.
- While the inverter is energized, be sure not to touch the inverter terminals even during stoppage. Otherwise, there is a danger of electric shock.
- If the re-try mode is selected, it may suddenly restart during the trip stop. Be sure not to approach the machine. (Be sure to design the machine so that personnel safety will be secured even if it restarts.) Otherwise, there is a danger of injury.
- Even if the power supply is cut for a short period of time, it may restart operation after the power supply is recovered if the operation command is given. If it may incur danger to personnel, be sure to make a circuit so that it will not restart after power recovery. Otherwise, there is a danger of injury.
- The Stop Key is effective only when the function is set. Be sure to prepare the Key separately from the emergency stop. Otherwise, there is a danger of injury.
- After the operation command is given, if the alarm reset is conducted, it will restart suddenly. Be sure to set the alarm reset after checking the operation command is off. Otherwise, there is a danger of injury.
- Be sure not to touch the inside of the energized inverter or to put a bar into it. Otherwise, there is a danger of electric shock and/or fire.

 **CAUTION**

- Radiating fin and discharging resistor will have high temperature. Be sure not to touch them.  
Otherwise, there is a danger of getting burned.
- Low to high speed operation of the inverter can be easily set. Be sure to operate it after checking the tolerance of the motor and machine.  
Otherwise, there is a danger of injury.
- If a motor is operated at a frequency higher than 60Hz, be sure to check the speeds of the motor and the machine with each manufacturer, and after getting their consent, operate them.  
Otherwise, there is a danger of machine breakage.

**Note:**

- (1) Make sure that the power lines (input power supply L1(L1), L2(N) and L3, and output terminals, U, V and W are connected correctly.
- (2) Make sure that there are no mistakes in the signal line connections.
- (3) Make sure that the inverter case () is grounded.
- (4) Make sure that terminals other than those specified are not grounded.
- (5) Make sure that the inverter is installed vertically on a wall, and a nonflammable material such as a steel plate is used as a mounting surface.
- (6) Make sure that there are no short-circuits caused by stray pieces of wire, solderless terminals or other objects left from wiring work. Also, make sure that no tools have been left behind.
- (7) Make sure that the output wires are not short-circuited or grounded.
- (8) Make sure that there are no loose screws or terminals.
- (9) Make sure that the maximum frequency setting matches the machine specifications.
- (10) With the digital operator removed, do not operate the inverter. Make sure that the digital operator or remote operator is connected before operating the inverter.

Be sure to refer to page 11-2 when conducting insulation resistance and withstand voltage tests. Never test terminals other than those which are indicated.

## 6.2 Test Run

An example of a general connection diagram is shown below.

Operating with digital operator:

When setting frequency, run and stop with digital operator.

(The same way as remote operator (DOP) or copy with (DRW).)

Running from external command:

When setting frequency, run and stop from external command (FW,RV Terminal.)

The following shows run from the operation box (OPE-4MJ2,OPE-8MJ2)

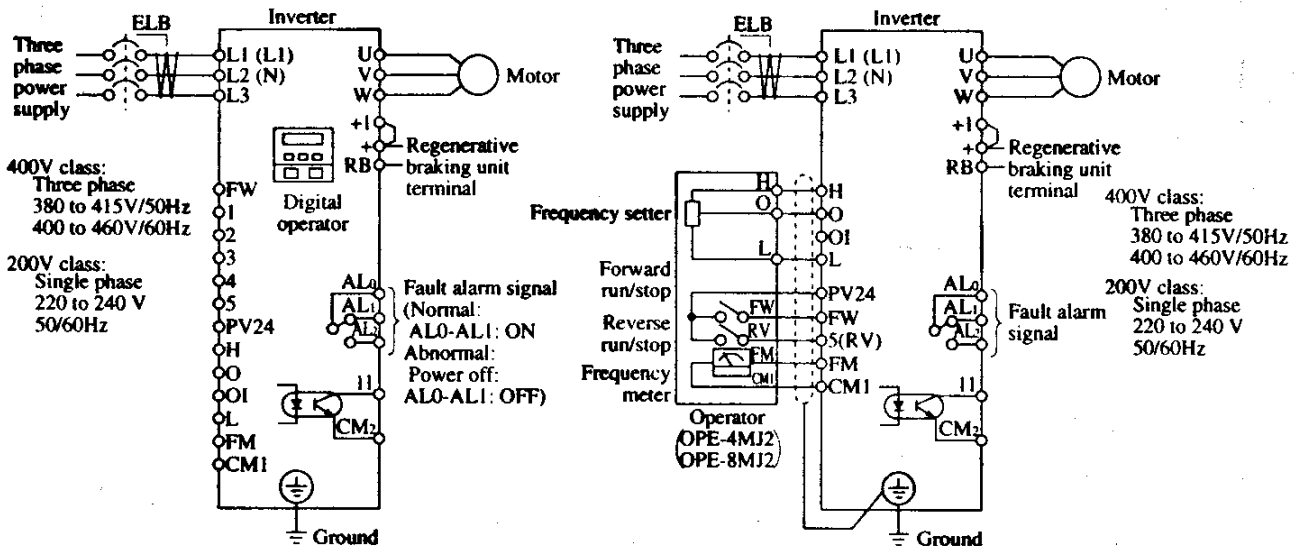

Procedure(Operating with digital operator)

- (1) Turn on ELB to supply power to the inverter. Make sure that the **POWER** LED on the digital operator goes ON.
- (2) Make sure that **F 9** is changed to **00**, or **02**.
- (3) Press **FUNC** twice and display **F 2**.
- (4) Set frequency with **▲**. Check the output frequency and direction of revolution.
- (5) Press **RUN** and start to run.

(Short circuit FW to PV24 or 5(RV) to PV24 when **F 9** is set to **02**.)

- (6) Press **STOP/RESET** and decelerate to a stop.



 **CAUTION**

Check the following before and during the test run.  
Otherwise, there is a danger of machine breakage.

- Was the short-cut bar between +1 and + removed?
- Was the direction of the motor correct?
- Was the inverter tripped during acceleration or deceleration?
- Were the rpm and frequency meter correct?
- Were there any abnormal motor vibrations or noise?

When overcurrent tripping or overvoltage tripping occurs during the test run,  
increase the acceleration time or deceleration time.

**Factory settings**

Maximum frequency: 50 Hz  
Forward operation

## 7. FUNCTION OF CONTROL CIRCUIT TERMINAL

### 7.1 List of Control Circuit Terminals

The initialization of the intelligent input terminals is "a contact" (they turn on when short-circuited). When they are to be used in the b contact state, it is necessary to switch the setting by .

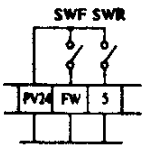
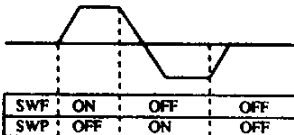
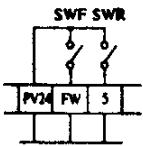
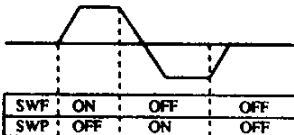
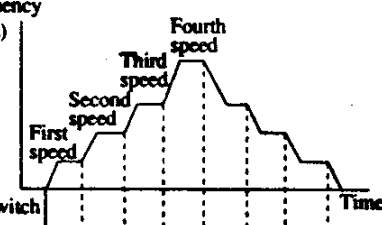
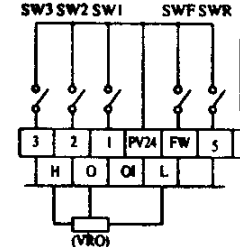
Terminal symbol	Function	Contents	
FW	Forward run/stop	SWF Contact (close): Forward run (open): Stop <div style="display: flex; justify-content: space-around; align-items: center;">   </div>	
5	Reverse run/stop	SWR Contact (close): Reverse run (open): Stop <div style="display: flex; justify-content: space-around; align-items: center;">   </div> <p style="text-align: center;">Terminal 5: ) Both contacts SWF and SWR are close-stop. REV</p>	
1	Multistage speed	<div style="display: flex; justify-content: space-between;"> <div style="width: 45%;"> <p>Frequency (Hz)</p>  <p>Time</p> </div> <div style="width: 45%;">  <p>Condition Terminal 1: CF1 Terminal 2: CF2 Terminal 3: CF3 Terminal 5: REV</p> </div> </div> <p style="text-align: right;">• Use SW3 to select the extended multistage speed</p>	
2			SW2
3			SW3
DB	External DC braking	When the terminal [DB] is turned on, the DC braking operation can be performed.	
STN	Initialization	This function is used for initialization (state which is set at factory before shipment). When the terminal [STN] is turned on and the equipment is reset or the power is turned on again, the equipment will be initialized.	
SET	2nd setting function	When the terminal [SET] is turned on, the set frequency, torque boost, acceleration and deceleration time, second acceleration and deceleration time, and control system can be changed in a batch.	
2CH	2 stage acceleration and deceleration	When the terminal [2CH] is turned on, the acceleration and deceleration can be executed by the 2 stage acceleration and deceleration time.	
FRS	Free run stop	When the terminal [FRS] is turned on, the inverter stops output and the motor enters the free run state.	
EXT	External trip	When the terminal [EXT] is turned on, the inverter enters the trip state, stops output, and displays E12.	
USP	Power reclosing restart prevention	When the terminal [USP] is turned on, the restart when the power is turned on with the running command kept on can be prevented.	
RS	Reset	When the terminal [RS] is turned on, the trip state can be canceled. During running, the output is stopped. NOTE: The function cannot be used in the b contact state.	
SFT	Software lock	When the terminal [SFT] is turned on, the data of each function is locked. However, the running monitor and frequency setting are valid.	
PV24	24 V DC power source	Common terminal for running terminal or intelligent terminal	
CM1	Common terminal 1	Common terminal for monitor terminal	

Terminal symbol	Function	Contents		
Frequency command	H	Power supply terminal to command a frequency	<ul style="list-style-type: none"> <li>Standard setting for external voltage signal is 0 to 4.8 V (5 V nominal). Voltage input 0 to 9.6 V (10 V nominal) can be switched by <b>A4B</b>.</li> </ul> <p style="text-align: center;">VRO (500 Ω to 2 kΩ)</p> <p style="text-align: center;">0 to 4.8 VDC (nominal 5 V), 0 to 9.6 VDC (nominal 10 V) Input impedance 30 kΩ</p> <p style="text-align: center;">4 to 19.6 mA DC (nominal 20 mA) Input impedance 250 Ω</p> <p><b>NOTE:</b> When an inconvenience occurs in the above characteristics, adjust it using <b>A8D</b> and <b>A8I</b>. The sum of both analog input signals is outputted. When selecting one of analog input current and voltage, make sure that the other is not inputted.</p>	
	O	Frequency command terminal (voltage command)		
	OI	Frequency command terminal (current command)		
	L	Frequency command common		
Monitor terminal	FM	Frequency monitor	• Analog frequency monitor/Digital frequency monitor/Analog output current monitor	
	CM1	Input monitor signal common	• Command terminal for the operation, software lock, and monitor terminals.	
Intelligent output terminal 11 (Note)	AR	Frequency arrival signal	<ul style="list-style-type: none"> <li>When [AR] is selected as a terminal, at the time of constant speed arrival, two types of methods for outputting a frequency more than an optionally set frequency can be executed.</li> </ul>	<p><b>Output terminal specification</b></p> <p>Open collector output 27 V DC max 50 mA max</p>
	RUN	RUN signal	• When [RUN] is selected as a terminal, the inverter outputs when the motor is driven.	
	OL	Overload -previous notice signal	• When [OL] is selected as a terminal, a current more than the set current (rate to the rated current) is outputted.	
CM2	Output signal common terminal	• Common terminal for intelligent output terminal		
AL0	Alarm terminal	In the normal state: AL0 and AL1 are closed.	<p>In the abnormal state or when power is turned off: AL0 and AL2 are closed. (At the time of initialization)</p> <p>Contact rating</p> <p>250 V AC 2.5 A (resistance load) 0.2 A (cosφ = 0.4)</p> <p>30 V DC 3.0 A (resistance load) 0.7 A (cosφ = 0.4)</p> <p>[ Minimum 100 V AC 10 mA 5 V DC 100 mA ]</p>	
AL1				
AL2				

NOTE: "b contact" is set by initialization for terminal 11. When "a contact" is to be used, switch the contact setting by **C21**.

## 7.2 Function Contents of Monitor Terminal

**Terminal name: Monitor terminal [FM]**  
(Analog, digital)

Function No.  
to be set

[A 50], [A 51],  
and [F 10]

### Function contents

Monitor output frequency signal or the current of the inverter is output from the control circuit terminal.

Monitor output current signal is output as an analog signal only.

#### ① Analog Frequency Monitor Signal

The meter outputs duty cycle in proportion to the output frequency with full scale at the maximum frequency.

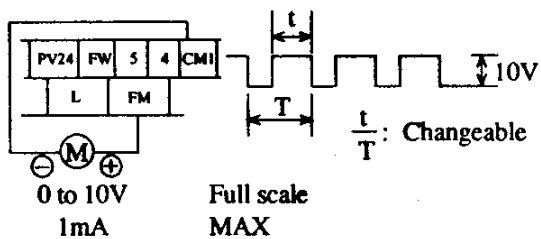

**NOTE:** This is a dedicated indicator, so that it cannot be used as a line speed signal.

Indication accuracy after adjustment: About  $\pm 5\%$  (The accuracy of some meters may exceed this value.)

#### ② Digital Frequency Monitor Signal

Pulse train of a frequency which is the same as the output frequency is output. The duty is about 50%.

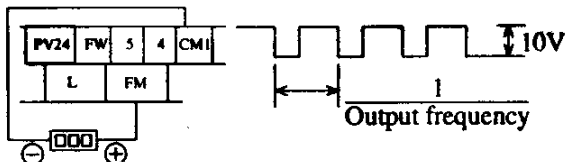

#### ③ Analog Current Monitor Signal

The duty cycle in proportion to the output current with full scale at 200% of the rated current of the inverter.

Specification of analog meter follows the analog frequency monitor specifications.

### Setting contents

1. Select Frequency Monitor or Current Monitor by [A 51].
2. When Frequency Monitor is selected, select Analog Meter or Digital Meter by [A 50]. (When Current Monitor is selected, analog data is outputted even if Digital Meter is selected.)
3. When the analog meter is used, adjust the meter so that the needle of the meter indicates the maximum value at the time of maximum frequency by [F 10] (analog meter adjustment).

### 7.3 Function Contents of Intelligent Input Terminals

<b>Terminal name: Reverse running/stop terminal [REV]</b>		<b>Function No.</b> <span style="border: 1px solid black; padding: 2px;">C 0</span> to <span style="border: 1px solid black; padding: 2px;">C 4</span> to be set
<div style="border: 1px solid black; padding: 2px; margin-bottom: 10px;">Function content</div> <ul style="list-style-type: none"> <li>When the running command is inputted via the terminal [REV], the terminal executes the reverse running command or stop command.</li> </ul> <div style="border: 1px solid black; padding: 2px; margin-bottom: 10px;">Terminal setting method</div> <div style="border: 1px solid black; padding: 5px;"> <p>Digital operator _____</p> <p>[REV] terminal setting (This is set in the terminal 5 at the time of initialization.) Set the set value [Reverse running command] <span style="border: 1px solid black; padding: 2px;">  0</span> in one of the input terminals <span style="border: 1px solid black; padding: 2px;">C 0</span> to <span style="border: 1px solid black; padding: 2px;">C 4</span>.</p> </div>	<div style="text-align: center; border: 1px solid black; padding: 5px; margin-bottom: 10px;"> <b>WARNING</b> </div> <p>When the power is turned on when the running command is on, the motor starts rotation and it is dangerous. Before turning the power on, confirm that the running command is not on.</p> <div style="border: 1px solid black; padding: 2px; margin-bottom: 10px;">Precautions</div> <ul style="list-style-type: none"> <li>When the running command is inputted via the forward running terminal [FW] and reverse running terminal [REV] at the same time, the running command enters a state which is the same as stop.</li> <li>Note that when the [REV] terminal is set to "b contact", the running automatically starts.</li> </ul>	

<b>Terminal name: Multispeed [CF1], [CF2], [CF3]</b>		<b>Function No.</b> <span style="border: 1px solid black; padding: 2px;">C 0</span> to <span style="border: 1px solid black; padding: 2px;">C 4</span> , <span style="border: 1px solid black; padding: 2px;">F 2</span> to be set <span style="border: 1px solid black; padding: 2px;">A 12</span> to <span style="border: 1px solid black; padding: 2px;">A 17</span> , <span style="border: 1px solid black; padding: 2px;">A 71</span>
<div style="border: 1px solid black; padding: 2px; margin-bottom: 10px;">Function content</div> <ul style="list-style-type: none"> <li>When [CF1], [CF2], and [CF3] are selected as intelligent input terminals, Multispeed 1 to Multispeed 7 can be set. When the frequency command from the normal operator (or terminal) is combined with them, up to 8 stages of running are available.</li> <li>When the control terminal is set at each speed by the switch, the numerical value displayed at <span style="border: 1px solid black; padding: 2px;">F 2</span> indicates the output frequency at the time of each multispeed. Set the speed as shown below.           <ol style="list-style-type: none"> <li>① Turn the running command off.</li> <li>② Turn each switch on and set it to Multispeed n. Display the data section of <span style="border: 1px solid black; padding: 2px;">F 2</span>.</li> <li>③ Set an optional output frequency by pressing the <span style="border: 1px solid black; padding: 2px;">▲</span> and <span style="border: 1px solid black; padding: 2px;">▼</span> keys.</li> </ol> </li> </ul>	<ol style="list-style-type: none"> <li>④ Press the <span style="border: 1px solid black; padding: 2px;">FUNC</span> key once so as to store the set frequency. If this occurs, <span style="border: 1px solid black; padding: 2px;">F 2</span> indicates the output frequency of Multispeed n.</li> <li>⑤ Press the <span style="border: 1px solid black; padding: 2px;">▲</span> and <span style="border: 1px solid black; padding: 2px;">▼</span> keys once. (Confirm that the indication is the same as the set frequency.)</li> <li>⑥ When the operations in (1) to (4) are repeated, the frequency of Multispeed n can be set. It can be set also by one of <span style="border: 1px solid black; padding: 2px;">A 12</span> to <span style="border: 1px solid black; padding: 2px;">A 17</span> and <span style="border: 1px solid black; padding: 2px;">A 71</span>.</li> </ol> <div style="border: 1px solid black; padding: 2px; margin-bottom: 10px;">Terminal setting method</div> <div style="border: 1px solid black; padding: 5px;"> <p>Digital operator _____</p> <p>Set the set values <span style="border: 1px solid black; padding: 2px;">  1</span>, <span style="border: 1px solid black; padding: 2px;">  2</span>, and <span style="border: 1px solid black; padding: 2px;">  3</span> in one of the input terminals <span style="border: 1px solid black; padding: 2px;">C 0</span> to <span style="border: 1px solid black; padding: 2px;">C 4</span>.</p> </div>	

### Example of output terminal connection

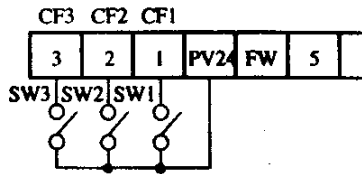

### Setting of multispeed

Multispeed	Control circuit terminal		
	SW1	SW2	SW3
Multispeed 1	ON	OFF	OFF
Multispeed 2	OFF	ON	
Multispeed 3	ON	ON	
Multispeed 4	ON	OFF	ON
Multispeed 5	OFF	ON	
Multispeed 6	ON	ON	
Multispeed 7	OFF	OFF	

### Precautions

- Up to the third speed of the multispeed can be set by initialization. When CF3 (allocated to the terminal 3 in this case) is set by the extended function mode [C 2], up to the seventh speed can be set.
- After any data is changed, be sure to press the **機能 FUNC** key every time and then set the next one. Note that when the **機能 FUNC** key is not pressed, no data will be set.
- When a frequency more than 120 Hz is to be set, it is necessary to switch the maximum frequency ( [A 64] ).

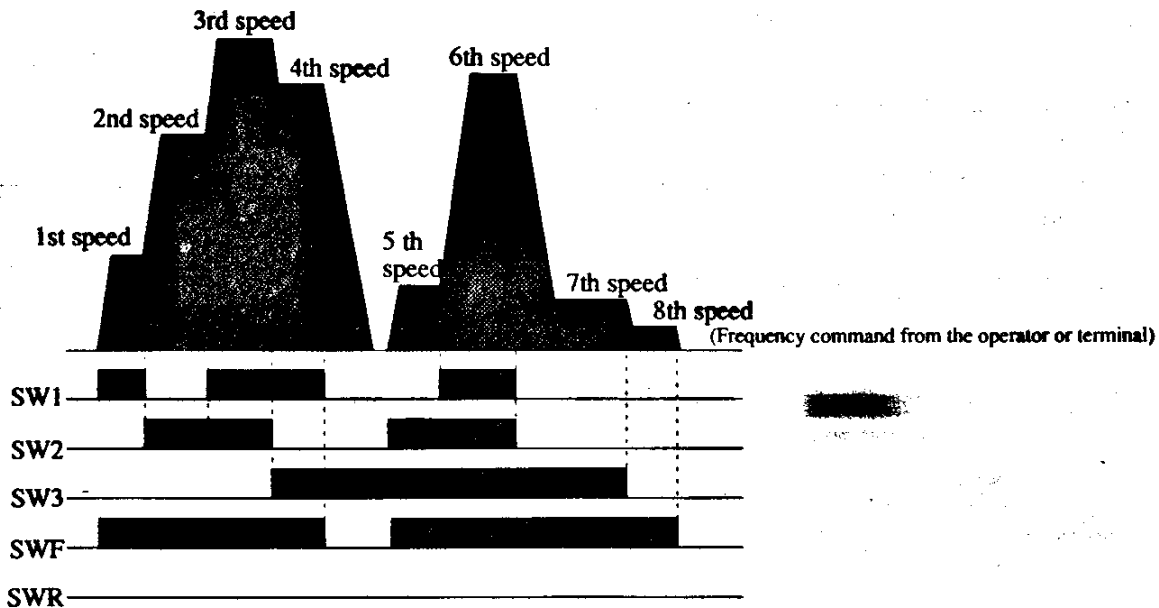

**Terminal name: External DC damping [DB]**

Function No. **C 0** to **C 4**  
to be set **A 21**, **A 22**, **A 56**

**Function content**

- When the terminal [DB] is turned on, the DC braking [DB] operation can be performed.

Necessary setting items when the external DC braking terminal is used

Set the following when the external DC braking terminal is to be used.

- ① **A 56** DC braking type selection
- ② **A 21** DC braking force setting
- ③ **A 22** DC braking time setting

**DC braking execution method**

- When the operation type is an edge operation  
Turn the switch between [DB] and [PV24] on and output DC braking only for the time of **A 22** DC braking time selection (at the time of stop).

- When the operation type is a level operation  
Output DC braking when the switch between [DB] and [PV24] is on. Time setting is not related to it.

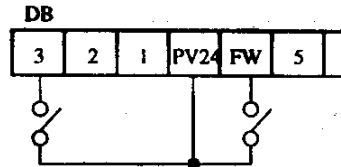

When [DB] is allocated to the terminal 3

**Precautions**

- As the DC braking force and DC braking time are increased, overload protection (**E 5**) is easily generated.

**Terminal setting method**

**Digital operator**

Set the set value **4** in one of the input terminals **C 0** to **C 4**.

**Level operation 1**

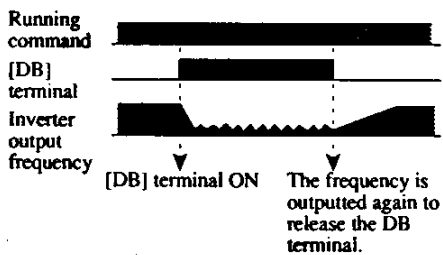

**Edge operation 1**

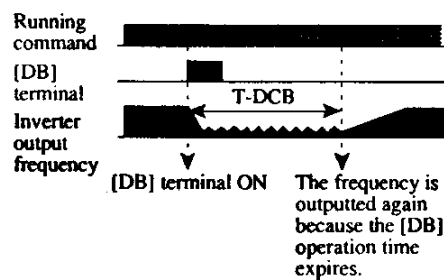

**Level operation 2**

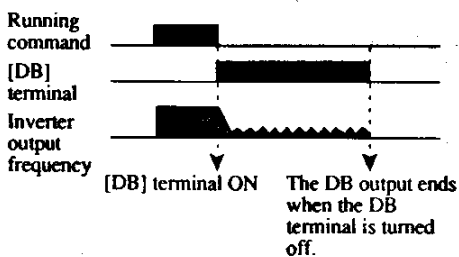

**Edge operation 2**

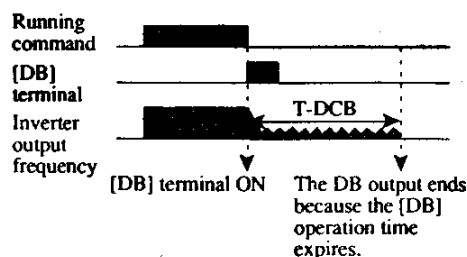

**Terminal name: Initialization**  
**(factory delivery state) [STN]**

**Function No. [C] 0 to [C] 4**  
**to be set**

When returning the equipment to the initial state at factory before shipment for some reason, follow the following procedure.

- ① Allocate [STN] (set value [ ] 5) to one of the input intelligent terminals. (Use [C] 0 to [C] 4 in the extended function mode to set an intelligent terminal.)
- ② Turn the switch between the [STN] and [PV24] terminals on and then turn the power off and on or perform the reset operation as shown in Note 1. (After the power is turned off, do not turn the power on again before the charge lamp of the logic substrate goes off.)
- ③ When 6 seconds or more pass after the power is turned on or the reset operation is performed, turn the switch between the [STN] and [PV24] terminals off. (When the key operation, reset operation, or power turning operation is performed before 6 seconds pass, the equipment may not be initialized.)

**NOTE 1:** For resetting, turn the switch between the [RS] and [PV24] terminals of the terminal block on and then off.

**NOTE 2:** When the software is locked, the equipment cannot be initialized.



**Terminal name: 2nd setting function [SET]**

**Function No. to be set** C 0 to C 4 (A 0 to A 2, A 18, A 19, A 62, A 63, F 2, F 5 to F 8)

**Function content**

- When the terminal [SET] is turned on, it is possible to set two types of motor constants and execute running by one inverter.
- Select the second setting function when the equipment is stopped.

**Functions which can be set by the second function**

- F2: Output frequency setting
- F5: V/f pattern setting
- F6: Acceleration time 1 setting
- F7: Deceleration time 1 setting
- F8: Manual torque boost setting
- A0: Control method
- A1: Motor capacity setting
- A2: Motor poles setting
- A18: 2-stage acceleration time setting
- A19: 2-stage deceleration time setting
- A62: Base frequency setting
- A63: Maximum frequency setting

**Function switching method**

While the switch between the set terminals [SET] and [PV24] is on, the equipment is operated by the setting of the second function.

When the terminal is turned off, the setting is returned to the original setting (first function).

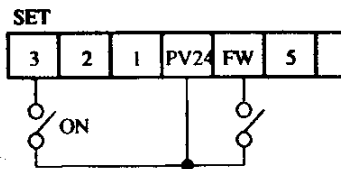

When [SET] is allocated to the terminal 3

**How to set the monitor and function modes when the second function is executed**

- To set the second set data, change the setting in the state that [SET] and [PV24] are turned on.
- Even when the [SET] terminal is switched during data display, the digital operator displays the same value and does not display the switched set data. When the display code is displayed, switch the [SET] terminal.
- In the digital operator, at the time of second setting, a decimal point is displayed in the first digit place of the data display section such as 22. However, when the acceleration and deceleration time, DC braking time adjustment time, and standby time after undervoltage display more than 100, it does not mean the second function setting. (When the remote operator is used for setting, there is no distinction display of the second setting. Confirm it from the state of ON or OFF of the terminal.)

**Terminal setting method**

Set the set value 6 in one of the input terminals C 0 to C 4.

**Precautions**

- Connect and turn on the [SET] terminal before the running command terminals (FW and REV terminals). When they are connected and turned on at the same time, the setting may not be switched to the second setting.

**Terminal name: Second stage acceleration and deceleration [2CH]**

**Function No. to be set** C 0 to C 4,  
A 18, A 19

**Function content**

- When the terminal [2CH] is turned on, the equipment can be accelerated or decelerated (acceleration time 2, deceleration time 2) by the 2 stage acceleration and deceleration time.

**Function switching method**

- While the switch between the set terminals [2CH] and [PV24] is on, the equipment operates by the 2 stage acceleration and deceleration time (acceleration time 2, deceleration time 2).
- When the terminal is turned off, the equipment is returned to the original acceleration and deceleration time (acceleration time 1, deceleration time 1).

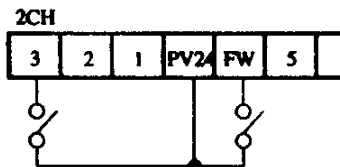

When [2CH] is allocated to the terminal 3

**Terminal setting method**

**Digital operator**

Set the set value   7 in one of the input terminals C 0 to C 4.

**2 stage acceleration and deceleration time setting method**

Use A 18 (acceleration time 2) and A 19 (deceleration time 2) to set the 2 stage acceleration and deceleration time (acceleration time 2, deceleration time 2).

Between terminals [2CH] and [CM1]	Acceleration and deceleration time for operation
OFF state	Acceleration time 1, Deceleration time 1
ON state	Acceleration time 2, Deceleration time 2

**Precautions**

When a time of more than 1000 seconds is set by the remote operator, the indication of the digital operator becomes   -  . (However, the operation during the set time will be executed.)

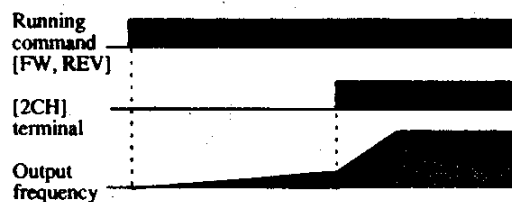

Terminal name: Free run stop [FRS]

Function No.   to

Function content

- When the terminal [FRS] is turned on, the inverter stops output and the motor enters the free run state.

Function switching method

- While the switch between the set terminals [FRS] and [PV24] is on, the equipment operates the FRS operation.

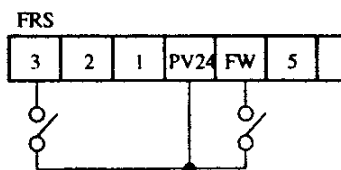

When [FRS] is allocated to the terminal 3

**NOTE:** "a contact" is set by initialization.

When "b contact" is to be used, switch the contact setting by

.

The contact setting cannot be switched only by selecting FRS by switching   to  .

Terminal setting method

Digital operator

Set the set value   in one of the input terminals   to  .

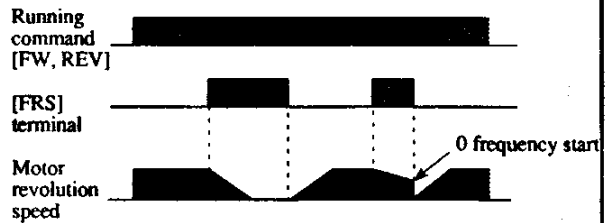

Terminal name: External trip [EXT]

Function No.   to   to be set

Function content

- When the terminal [EXT] is turned on, the inverter enters the trip state by an indication of   and stops output.

Terminal setting method

Digital operator

Set the set value   in one of the input terminals   to  .

Function switching method

When the switch between the set terminals [EXT] and [PV24] is turned on, the equipment enters the trip state. Even when the switch is turned off, the trip state will not be canceled. Reset the equipment or turn the power off and on again to cancel the trip state.

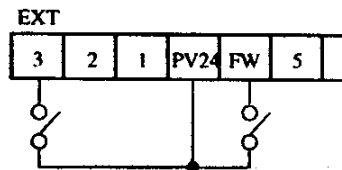

When [EXT] is allocated to the terminal 3

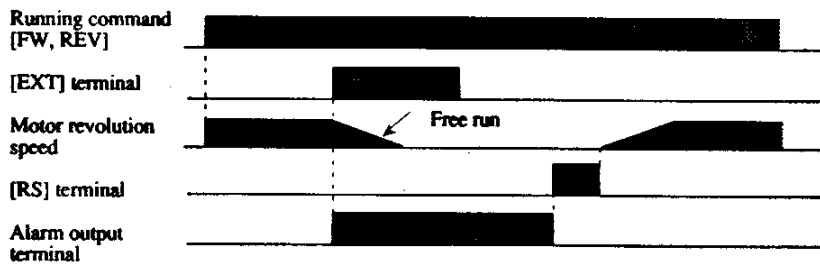

Terminal name: **Prevention function of restart upon power on [USP]**

Function No. **C 0** to **C 4** to be set

**Function content**

- If the running command is set when power is turned on, the inverter starts running immediately after it is activated. The USP function prevents it so that the inverter will not execute sudden running.
- To reset an alarm and restart running, turn the running command off (Note 1) or perform a reset operation by the terminal [RS] or the **停止/リセット STOP/RESET** key. Refer to the time chart indicated below.

**NOTE 1:** When the running command is turned off, the indication is switched to **E r r** but the trip state will not be canceled.

**Set content**

Digital operator

Set the set value **10** in one of the input terminals **C 0** to **C 4**.

**Function switching method**

While the switch between the set terminals [USP] and [PV24] is on, the equipment executes the USP operation. If the power is turned on when the running command is inputted, the equipment enters the USP trip state (**E 13**).

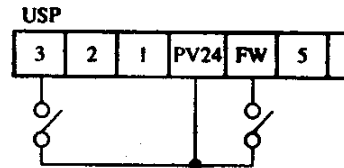

When [USP] is allocated to the terminal 3

**Precautions**

- Note that when a USP error occurs and it is canceled by resetting in the state that the running command from the terminal is inputted, the inverter restarts running immediately.
- Even when the trip state is canceled by turning the terminal [RS] on and off after an insufficient voltage protection (**E 9**) occurs, this function will be performed.
- When the running command is inputted immediately after the power is turned on, a USP error will be caused. When this function is used, input the running command two (2) seconds after the power is turned on.

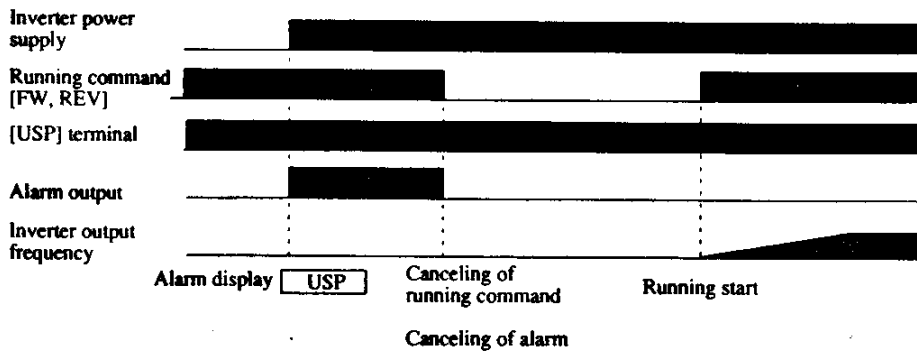

Terminal name: Reset [RS]

Function No.   to   to be set

### Function content

- The trip content can be canceled.
- The function is used to return each setting to the initialization (state which is set at factory before shipment). See page 7-7, "Initialization".
- The function is used to erase the trip history data. Set   trip history clear selection.

### Terminal setting method

#### Digital operator

Set the set value   in one of the input terminals   to  .

### Function switching method

- When the switch between the set terminals [RS] and [PV24] is turned on and off, the equipment executes the reset operation. (Reset [RS] is allocated to the control terminal 4 by initialization.)

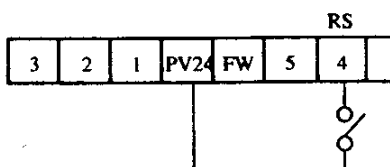

When [RS] is allocated to the terminal 4 (Initialization)

### WARNING

- After the operation command is given, if the alarm reset is conducted, it will restart suddenly. Be sure to set the alarm reset after checking that the operation command is off. Otherwise, there is a danger of injury.

### Precautions

- When the control terminal [RS] is kept on continuously for more than 4 seconds before using it, the display of the remote operator becomes R-ERROR COMM<2> (the display of the digital operator is    ). However, the inverter is normal. To return the display to the original one, open the terminal [RS] and press one of the keys of the operator.
- When the [RS] terminal is turned off from on, it becomes valid.
- The  STOP/RESET key of the digital operator is valid only when an alarm occurs.
- Only "a contact" (NO) can be set to the [RS] terminal. The terminal cannot be used in the "b contact" (NC) state.
- Even when the power is turned off or on, the function of the terminal is the same as that of the reset terminal.

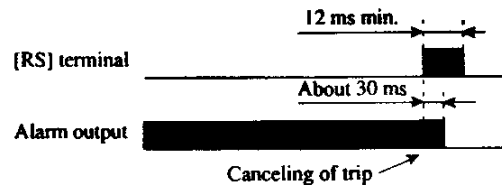

Terminal name: Terminal software lock [SFT]

Function No.  
to be set

[C] [0] to [C] [4]

#### Function content

- When the terminal [SFT] is turned on, the data of all the functions except the output frequency is locked by initialization. When the data is locked, no data can be changed.

#### Terminal setting method

Digital operator

Set the set value [ ] [12] in one of the input terminals [C] [0] to [C] [4].

#### Function switching method

When the switch between the set terminals [SFT] and [PV24] is turned on, the equipment enters the software lock state.

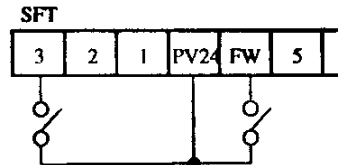

When [SFT] is allocated to the terminal 3

#### Precautions

- When the [SFT] terminal is turned on by initialization, only the output frequency can be changed.
- Software lock can be made possible also for the output frequency by [A] [53].
- Software lock by the operator is also possible without the [SFT] terminal being used. ([A] [84])

**7.4 Function Contents of Intelligent Output Terminals**  
 (Initial setting is "b contact" (NC) state)

**Terminal name:** Frequency arrival signal [AR]      **Function No.** C 10, A 39,  
 to be set A 40, A 49

**Function content**

- When [AR] is selected as an intelligent output terminal, at the time of constant speed arrival, two types of methods for outputting a frequency more than an optionally set frequency can be executed. Select the output method by A 49. Set an optionally set frequency by A 39 (setting at the time of acceleration) or A 40 (setting at the time of deceleration).

**Connection example of output terminal**

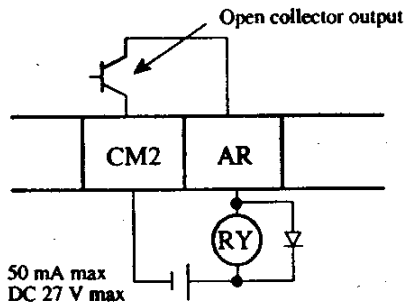

**Terminal setting method**

**Digital operator**

Set the set value 0 in the output terminal C 10.

**Precautions**

- At the time of acceleration, an output signal at a frequency between the set frequency - 0.5 Hz to + 1.5 Hz is turned on.
- At the time of deceleration, an output signal at a frequency between the set frequency + 0.5 Hz to - 1.5 Hz is turned on.

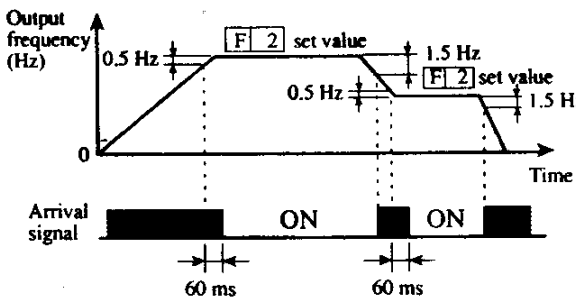

At the time of constant speed arrival

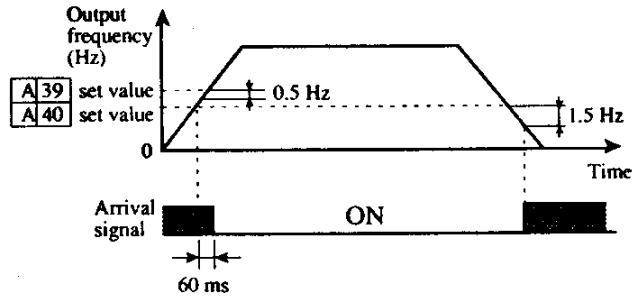

More than optionally set frequency

**NOTE:** When an arrival signal is outputted, a delay of about 60 ms occurs.



Terminal name: Run signal [RUN]

Function No. **C | 10**  
to be set

Function content

- When [RUN] is selected as an intelligent output terminal, the inverter outputs a RUN signal when the motor is driven.

Connection example of output terminal

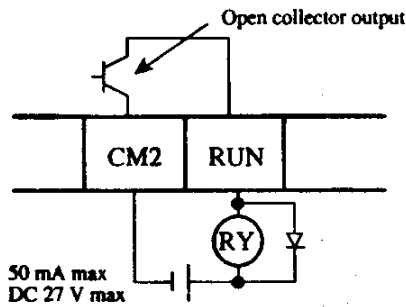

Terminal setting method

Digital operator

Set the set value **□ | 1** in the output terminal **C | 10**.

Precautions

- A RUN signal is outputted simultaneously when a gate signal of the power module is outputted. Therefore, when the frequency of the RUN signal is less than the start frequency adjustment value **A | 4**, it will not be outputted.
- A RUN signal can be outputted even during DC braking by **A | 52**.

FW (REV)

**A | 4**  
set value

Inverter output frequency

RUN

ON

**Terminal name: Overload advance notice signal [OL]**

**Function No. to be set** C 10

**Function content**

- When an output current more than the set current (rate to the rated current) flows, the terminal outputs a signal.

**Connection example of output terminal**

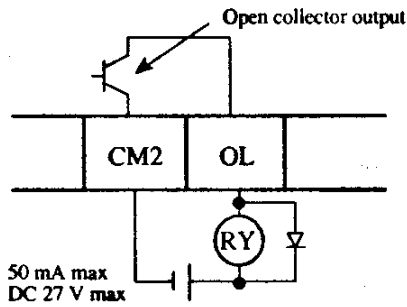

**Terminal setting method**

**Digital operator**

Set the set value 2 in the output terminal C 10.

**Precautions**

A value of 150% is set by initialization. To change the level, change A 30 (overload advance notice level).

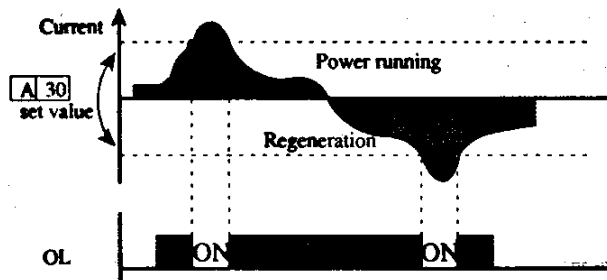

## 7.5 Function Contents of Alarm Terminals

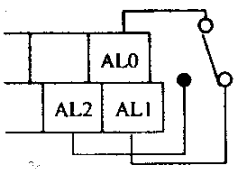
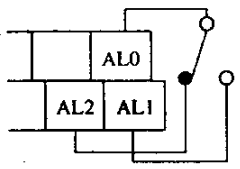
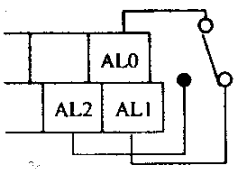
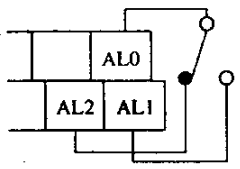
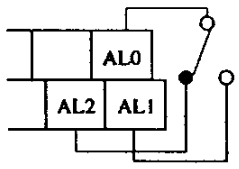
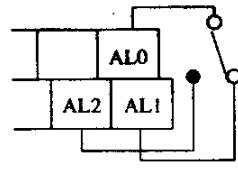
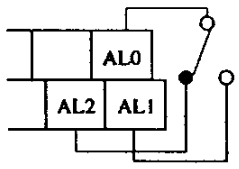
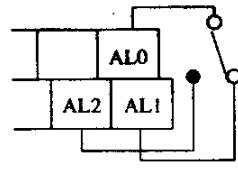
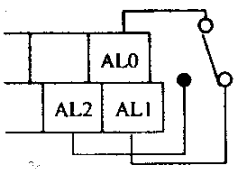
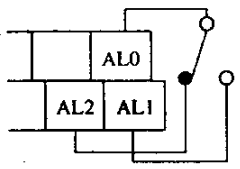
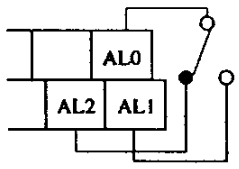
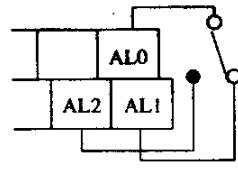
Terminal name: Alarm terminal [AL1, AL2-AL0]		Function No. <span style="border: 1px solid black; padding: 2px;">C 21</span> to be set																																					
<div style="border: 1px solid black; padding: 5px; margin-bottom: 10px;"> <b>Function content</b> </div> <ul style="list-style-type: none"> <li>When an alarm occurs, the function outputs an alarm signal from the terminals [AL0], [AL1], and [AL2] via the c contact. If this occurs, the operator displays the alarm content.</li> </ul> <div style="border: 1px solid black; padding: 5px; margin-bottom: 10px;"> <b>Terminal setting method</b> </div> <div style="border: 1px solid black; padding: 5px;"> <b>Digital operator</b> <ul style="list-style-type: none"> <li>"a contact" or "b contact" can be selected by <span style="border: 1px solid black; padding: 2px;">C 21</span>.</li> <li>The initialization is "b contact".</li> </ul> </div>	<div style="border: 1px solid black; padding: 5px; margin-bottom: 10px;"> <b>Precautions</b> </div> <ul style="list-style-type: none"> <li><b>Holding of an alarm signal</b> When an alarm signal is outputted, the alarm content will be stored even if the input power is turned off. Therefore, by turning the power on again, the content can be confirmed. However, when the input power is turned off, the alarm output will be reset (canceled) when the power is turned on again next. Therefore, to hold the alarm output, hold the alarm once by the external sequence and then turn the power switch of the inverter off.</li> <li>When the alarm contact output is set ON during normal running (b contact), a time delay occurs until the contact is closed when the power is turned on. Therefore, when the alarm contact output is to be used, set a delay of about 2 seconds when the power is turned on. (In the case of b contact, the contact may chatter when the power is turned on or off. If a fault may be caused by this, provide an interlock in the external circuit.)</li> </ul>																																						
<b>Contact specification</b> <table border="1" style="width: 100%; border-collapse: collapse; margin-top: 10px;"> <thead> <tr> <th style="width: 50%;">Maximum</th> <th style="width: 50%;">Minimum</th> </tr> </thead> <tbody> <tr> <td>AC 250V, 2.5A (load R) 0.2A (cos<math>\phi</math>=0.4)</td> <td>AC 100 V, 10 mA</td> </tr> <tr> <td>DC 30 Vm, 3.0A (load R) 0.7A (cos<math>\phi</math>=0.4)</td> <td>DC 5 V, 100 mA</td> </tr> </tbody> </table>				Maximum	Minimum	AC 250V, 2.5A (load R) 0.2A (cos $\phi$ =0.4)	AC 100 V, 10 mA	DC 30 Vm, 3.0A (load R) 0.7A (cos $\phi$ =0.4)	DC 5 V, 100 mA																														
Maximum	Minimum																																						
AC 250V, 2.5A (load R) 0.2A (cos $\phi$ =0.4)	AC 100 V, 10 mA																																						
DC 30 Vm, 3.0A (load R) 0.7A (cos $\phi$ =0.4)	DC 5 V, 100 mA																																						
<p>The alarm output terminals are connected as shown in Fig. (a) at the time of initialization. They can be changed as shown in Fig. (b) by setting <span style="border: 1px solid black; padding: 2px;">C 21</span>.</p>																																							
<div style="border: 1px solid black; padding: 5px;"> <p style="text-align: center;">(a) b contact (at the time of initialization)</p> <table style="width: 100%; border-collapse: collapse;"> <tr> <td style="width: 50%; border: 1px solid black; padding: 5px;"> <p style="text-align: center;">During normal running</p>  </td> <td style="width: 50%; border: 1px solid black; padding: 5px;"> <p style="text-align: center;">When an alarm occurs or power is turned off</p>  </td> </tr> </table> </div>		<p style="text-align: center;">During normal running</p> 	<p style="text-align: center;">When an alarm occurs or power is turned off</p> 	<div style="border: 1px solid black; padding: 5px;"> <p style="text-align: center;">(b) a contact</p> <table style="width: 100%; border-collapse: collapse;"> <tr> <td style="width: 50%; border: 1px solid black; padding: 5px;"> <p style="text-align: center;">During normal running or when power is turned off</p>  </td> <td style="width: 50%; border: 1px solid black; padding: 5px;"> <p style="text-align: center;">When an alarm occurs</p>  </td> </tr> </table> </div>		<p style="text-align: center;">During normal running or when power is turned off</p> 	<p style="text-align: center;">When an alarm occurs</p> 																																
<p style="text-align: center;">During normal running</p> 	<p style="text-align: center;">When an alarm occurs or power is turned off</p> 																																						
<p style="text-align: center;">During normal running or when power is turned off</p> 	<p style="text-align: center;">When an alarm occurs</p> 																																						
<table border="1" style="width: 100%; border-collapse: collapse;"> <thead> <tr> <th>Contact</th> <th>Power</th> <th>Running state</th> <th>AL0-AL1</th> <th>AL0-AL2</th> </tr> </thead> <tbody> <tr> <td rowspan="3" style="text-align: center;">b (Initialized value)</td> <td>ON</td> <td>Normal</td> <td>Closed</td> <td>Open</td> </tr> <tr> <td>ON</td> <td>Abnormal</td> <td>Open</td> <td>Closed</td> </tr> <tr> <td>OFF</td> <td>—</td> <td>Open</td> <td>Closed</td> </tr> </tbody> </table>		Contact	Power	Running state	AL0-AL1	AL0-AL2	b (Initialized value)	ON	Normal	Closed	Open	ON	Abnormal	Open	Closed	OFF	—	Open	Closed	<table border="1" style="width: 100%; border-collapse: collapse;"> <thead> <tr> <th>Contact</th> <th>Power</th> <th>Running state</th> <th>AL0-AL1</th> <th>AL0-AL2</th> </tr> </thead> <tbody> <tr> <td rowspan="3" style="text-align: center;">a</td> <td>ON</td> <td>Normal</td> <td>Open</td> <td>Closed</td> </tr> <tr> <td>ON</td> <td>Abnormal</td> <td>Closed</td> <td>Open</td> </tr> <tr> <td>OFF</td> <td>—</td> <td>Open</td> <td>Closed</td> </tr> </tbody> </table>		Contact	Power	Running state	AL0-AL1	AL0-AL2	a	ON	Normal	Open	Closed	ON	Abnormal	Closed	Open	OFF	—	Open	Closed
Contact	Power	Running state	AL0-AL1	AL0-AL2																																			
b (Initialized value)	ON	Normal	Closed	Open																																			
	ON	Abnormal	Open	Closed																																			
	OFF	—	Open	Closed																																			
Contact	Power	Running state	AL0-AL1	AL0-AL2																																			
a	ON	Normal	Open	Closed																																			
	ON	Abnormal	Closed	Open																																			
	OFF	—	Open	Closed																																			

## 8. OPERATION OF THE DIGITAL OPERATOR

### 8.1 Name of Keys

#### Monitor (LED display)

This display shows frequency, motor current, DV voltage, motor direction, and type.

#### POWER Lamp

Power lamp of control circuit

#### NOTE:

Use the charge lamp on the right of the terminal block to confirm the DC voltage after power is turned off.

#### FUNC (Function) key

This key is used for changing commands. When pressing key after setting data and parameter, they are automatically memorized.

#### Up key, Down key

These keys are used to change data and increase or decrease the frequency.

#### RUN key

This key is used for starting. (When terminal run is selected, this key does not work.)

#### STOP/RESET key

This key is used for stopping the motor or resetting errors. (When either operator or terminal is selected, this key works. If the extension function is used, this function is void.)

### 8.2 Operation Procedure (Example that the frequency is set and the equipment starts running)

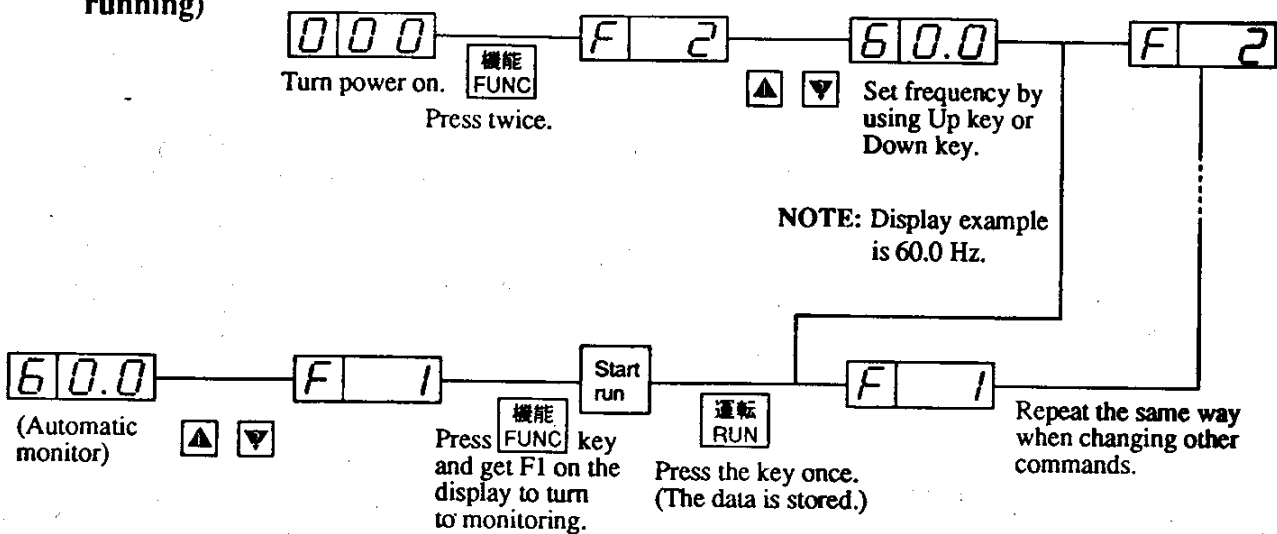

### 8.3 Key Description



[Function key] . . . This key allows the selection of commands and memorizes parameters.

When each time the key is pressed, the display changes as follows.

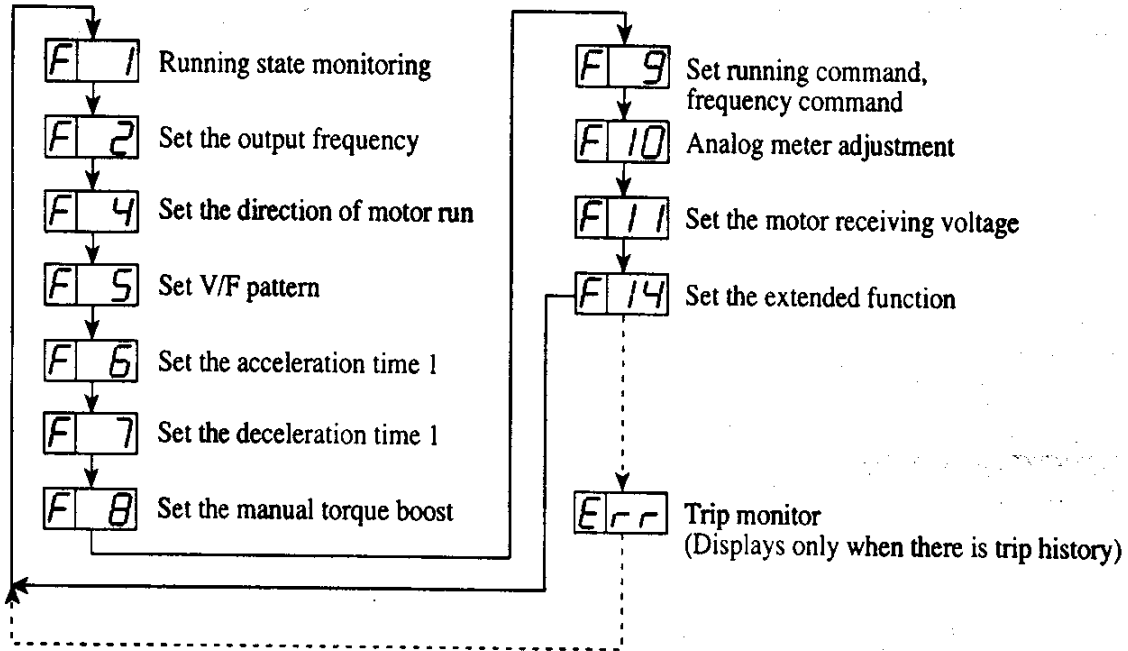

[Up key, Down key] . . . These keys change the values of data, and parameters.



Pushing down this key once under **F 1** to **F 14** condition moves to the data state.

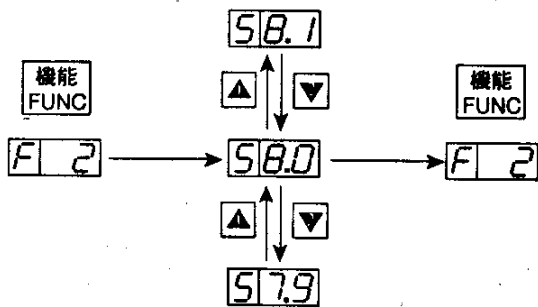

**NOTE:** After the data is changed, be sure to press the **機能 FUNC** key.



[RUN key] . . . This key starts the run.

The set value of **F 4** determines a forward run or a reverse run.



[STOP/RESET key] . . . This key stops the run.

When a trip occurs, this key becomes the reset key.

## Screen transfer for extended commands

When an extended command is to be used, select the extended function command No. from **F14** by using the keys **▲** and **▼** so as to enter the extended function mode.

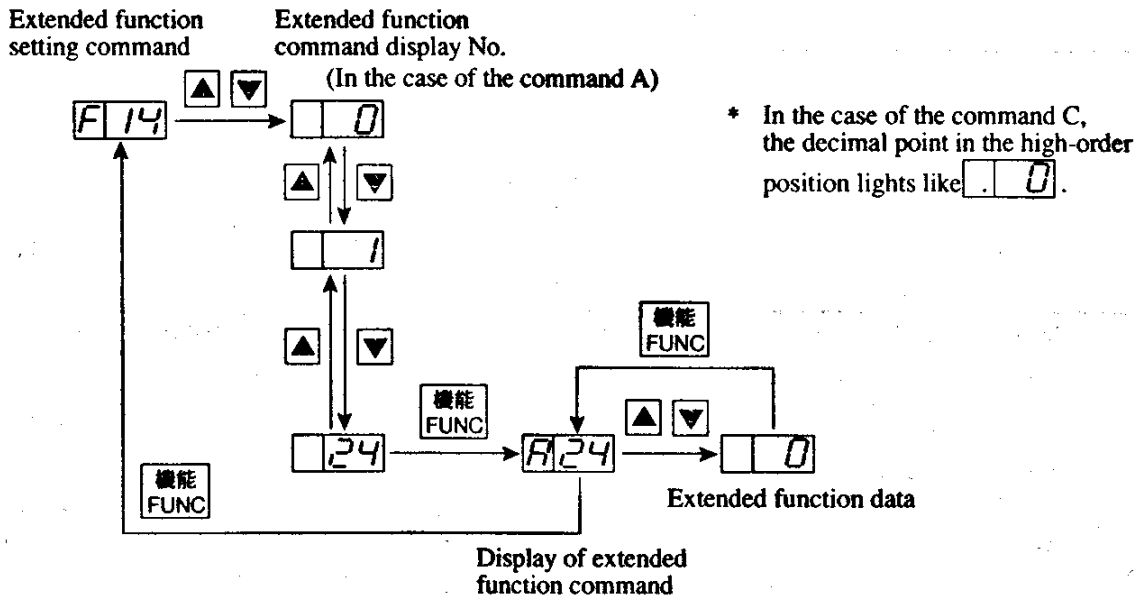

## Explanation of screen display

- ① When the inverter is turned on, the display which is outputted when the power is turned off before it is turned on appears. However, when the data display section for the commands F4 to F14 is turned off, the command display (F4 to F14) at that time appears.
- ② At the time of second setting, the decimal point in the first position of the data display section is displayed like **.22**. However, a display of more than 100 of the set frequency, acceleration and deceleration time, DC braking time adjustment time, or standby time after undervoltage does not mean the second setting.

## 8.4 Initialization List of Digital Operator

### (1) Monitor mode, function mode

The initialized value and settable range of each mode are displayed.

For extended function setting of **F14**, the extended functions shown on pages 8-5 and 8-6 can be set.

Display order	Function name	Type	Screen display			Initializa- tion	Application of 2nd setting function
			Command display	Settable during running	Range of set values		
1	Running state monitoring	Monitor- ing	F1	—	Frequency, current, DC voltage, rotational direction	—	—
2	Output frequency setting	Setting	F2	√	0.0 to 99.9 Hz/0 to 360 Hz	0.0	√
3	Running direction setting	Setting	F4	—	F/r (Forward/reverse)	F	—
4	V/f pattern setting	Setting	F5	—	0 to 57	NOTE 1	√
5	Acceleration time 1	Setting	F6	√	0.1 to 99.9 seconds, 100 to 999 seconds	NOTE 2	√
6	Deceleration time 1	Setting	F7	√	0.1 to 99.9 seconds, 100 to 999 seconds	NOTE 2	√
7	Manual torque boost setting	Setting	F8	√	0 to 99	11	√
8	Running command, frequency command setting	Setting	F9	—	0 to 3	03	—
9	Analog meter adjustment	Setting	F10	√	1 to 99	72	—
10	Motor receiving voltage setting	Setting	F11	—	200 to 240 V/380 to 460 V NOTE 3	NOTE 4	—
11	Extended function setting	Setting	F14	—	0 to 85/ .0 to .21 NOTE 5	0	—

NOTE 1: 08 for 200 V class, 00 for 400 V class

NOTE 2: 10 seconds for 200 V class, 15 seconds for 400 V class

NOTE 3: For the 200 V class, one of 200, 220, 230, and 240 can be selected. For the 400 V class, one of 380, 400, 415, 440, 460, and 480 can be selected.

NOTE 4: 220 V for 200 V class, 380 V for 400 V class

NOTE 5: No extended function can be set during running. However, the set value of each function can be monitored.

(2) Extension function mode

- Each function name and settable range to the extension function mode are shown below.
- Set the extension function code to be changed by **F14**.

Display order	Extended function name	Screen display		Initial value	Settable for 2nd function	Remarks	Ref. page
		Code display	Setting range				
1	Control method	A 0	0-2	0	√		8-15
2	Motor capacity setting	A 1	0.2-5.5	NOTE 1	√		8-15
3	Motor poles setting	A 2	2/4/6/8	4	√		8-15
4	Maximum frequency adjustment	A 3	0.0-15 Hz	0.0	—		8-16
5	Start frequency adjustment	A 4	0.5-5.0 Hz	0.5	—		8-17
6	Upper frequency limiter setting	A 5	0-375 Hz	0	—		8-17
7	Lower frequency limiter setting	A 6	0-375 Hz	0	—		8-17
8	Jump frequency setting 1	A 7	0-375 Hz	0	—		8-18
9	Jump frequency setting 2	A 8	0-375 Hz	0	—		8-18
10	Jump frequency setting 3	A 9	0-375 Hz	0	—		8-18
11	Carrier frequency setting	A10	5/8/12/16 Hz	16	—		8-18
12	Frequency command sampling setting	A11	1-8	8	—		8-19
13	Multispeed first speed setting	A12	0-375 Hz	0	—		8-20
14	Multispeed second speed setting	A13	0-375 Hz	0	—		8-20
15	Multispeed third speed setting	A14	0-375 Hz	0	—		8-20
16	Multispeed forth speed setting	A15	0-375 Hz	0	—		8-20
17	Multispeed fifth speed setting	A16	0-375 Hz	0	—		8-20
18	Multispeed sixth speed setting	A17	0-375 Hz	0	—		8-20
19	2-stage acceleration time setting	A18	0.1-999s	10.0	√	Changeable during RUN	8-21
20	2-stage deceleration time setting	A19	0.1-999s	10.0	√	Changeable during RUN	8-21
21	DC braking frequency setting	A20	0.5-375 Hz	0.5	—		8-21
22	DC braking force adjustment	A21	0-36 (400 V:0-20)	0	—		8-21
23	DC braking time adjustment	A22	0-600s	0	—		8-21
24	Electronic thermal level adjustment	A23	20-120%	100	—		8-22
25	Electronic thermal characteristic selection	A24	0/1	1	—		8-22
26	External frequency setting start	A26	0-375 Hz	0	—		8-19
27	External frequency setting end	A27	0-375 Hz	0	—		8-19
28	Acceleration selection (Linear, S-curve)	A28	0/1	0	—		8-23
29	Deceleration selection (Linear, S-curve)	A29	0/1	0	—		8-23
30	Overload previous notice signal setting	A30	50-150%	150	—		8-23
31	Overload limit level setting	A31	50-150%	150	—		8-23
32	Overload limit content selection	A32	0/1	0	—		8-24
33	LAD stop function setting	A33	0/1	0	—		8-24
34	Trip/retry function selection	A34	0/1	0	—		8-24
35	Trip ignorance selection	A35	0(off)/1(on)	0	—		8-24
36	AVR voltage setting for deceleration	A36	0/1	0	—		8-25
37	Motor voltage setting for deceleration	A37	200-270 V/380-540 V/000	220/380	—	000:Invalid during decel.	8-25
38	Dynamic braking usage ratio	A38	0.1-30.0, 31.0	5	—	31.0:BRD invalid	8-25
39	Optional arrival frequency for acceleration	A39	0-100%	100	—		8-26



Display order	Extended function name	Screen display		Initial value	Settable for 2nd function	Remarks	Ref. page
		Code display	Setting range				
40	Optional arrival frequency for deceleration	A 40	0-100%	100	—		8-26
41	Forward rotation	A41	0(off)/1(on)	1	—		8-26
42	Reverse rotation	A42	0 (off) / 1 (on)	1	—		8-26
43	Stop key ON/OFF selection	A43	0/1	0	—		8-27
44	Analog input selection	A48	0(5 V)/1 (10 V)	0	—		8-19
45	Frequency arrival signal output method	A49	1/2	2	—		8-26
46	Analog/digital meter selection	A50	0/1	1	—		8-27
47	Frequency/current monitoring selection	A51	0/1	0	—		8-27
48	RUN signal output selection	A52	1/2	1	—		8-27
49	Enable/disable of frequency setting for software lock	A53	0/1	0	—		8-28
50	DC braking ON/OFF selection	A55	0 (off) / 1 (on)	0	—		8-22
51	DC braking edge/level selection	A56	0/1	1	—		8-22
52	Trip history clear selection	A57	0/1	0	—		8-28
53	Reduced voltage start selection	A58	0/1	1	—		8-28
54	Base frequency setting	A62	50-360 Hz	50	√		8-16
55	Maximum frequency setting	A63	50-360 Hz	50	√		8-16
56	Maximum frequency switching	A64	0 (120 Hz) / 1 (360 Hz)	0	—		8-16
57	Jump frequency range setting	A68	0-9.9 Hz	0.5	—		8-18
58	Multispeed seventh speed setting	A71	0-375 Hz	0	—		8-20
59	Frequency command adjust. (voltage)	A80	0-255	NOTE 2	—		8-29
60	Frequency command adjust. (current)	A81	0-255	NOTE 2	—		8-29
61	Allowable undervoltage time setting	A82	0.3-3.0s	1.0	—		8-29
62	Undervoltage retry waiting time	A83	0.3-100.0s	10.0	—		8-29
63	Software lock selection	A84	0/1	0	—		8-30
64	Deceleration rate setting for overload limit	A85	0.1-31.0s	1.0	—	31.0:Invalid	8-23
65	Input terminal setting 1	C0	0-12	1	—		8-31
66	Input terminal setting 2	C1	0-12	2	—		8-31
67	Input terminal setting 3	C2	0-12	7	—		8-31
68	Input terminal setting 4	C3	0-12	11	—		8-31
69	Input terminal setting 5	C4	0-12	0	—		8-31
70	Output terminal setting	C10	0-2	0	—		8-32
71	Input terminal a and b contact setting	C20	00-1F	00	—		8-33
72	Output terminal a and b contact setting	C21	00-03	03	—		8-34

**NOTE 1:** The most applicable motor capacity of the inverter is set.







**NOTE 2:** The initial setting of each inverter is adjusted when shipping from the works.

## 8.5 Explanation of the Mode

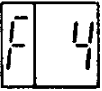
### (1) Monitor mode and Function mode







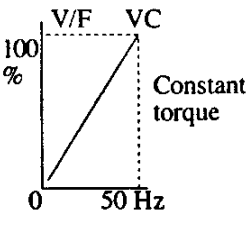
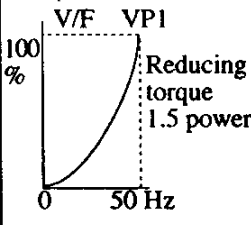
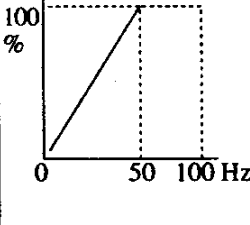
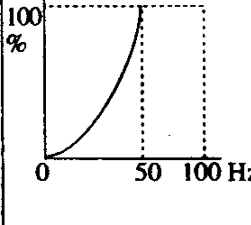
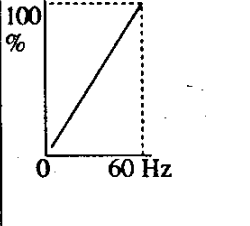
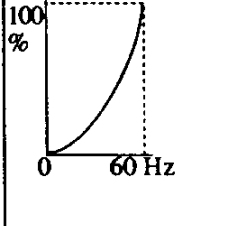
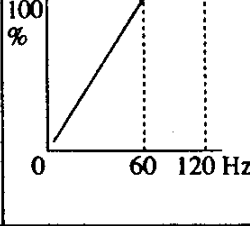
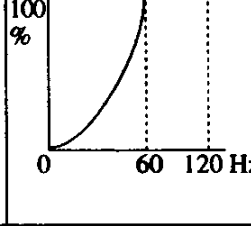
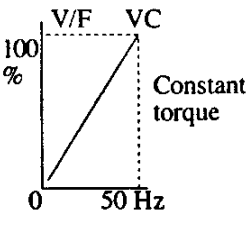
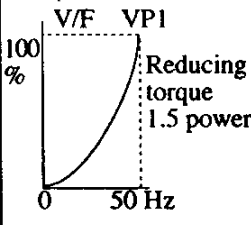
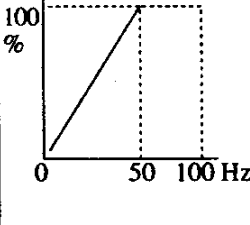
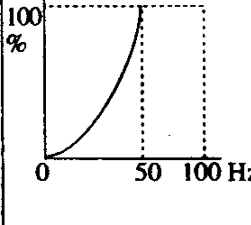
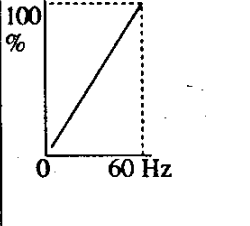
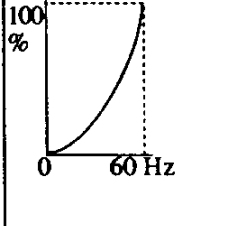
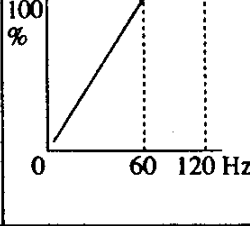
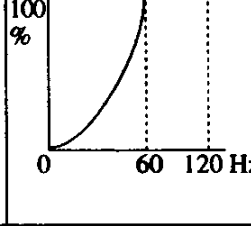
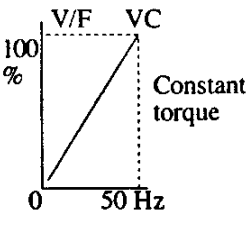
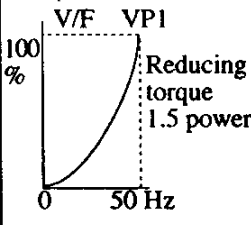
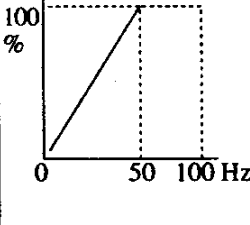
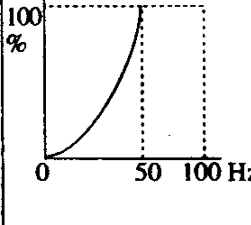
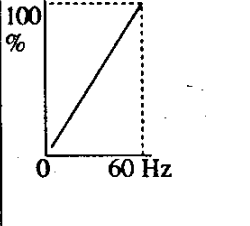
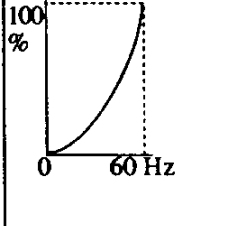
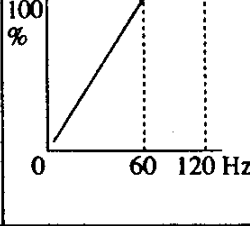
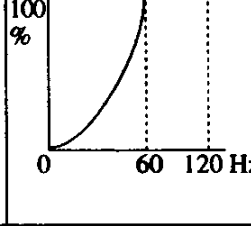

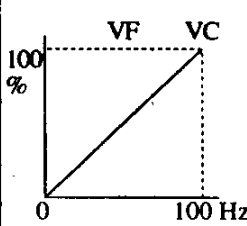
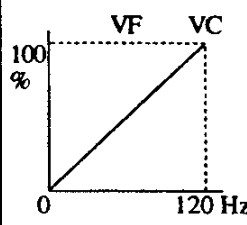
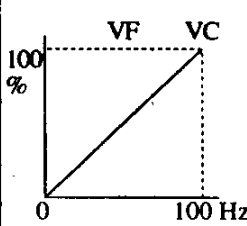
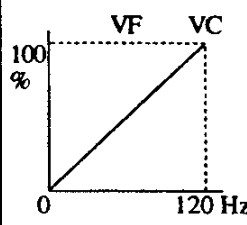
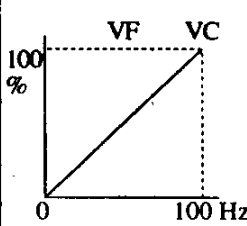
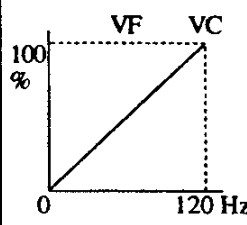











Command	Contents and display	Remarks
<div data-bbox="92 360 193 450" style="border: 1px solid black; padding: 2px; display: inline-block;">F   I</div>  Running state monitoring	<p data-bbox="240 360 1098 483">                         This command monitors the run state                          Frequency, output current, DC voltage and direction of revolution are displayed sequentially.                          [During run]                     </p> <div data-bbox="233 495 576 1541"> </div> <div data-bbox="603 533 1177 981"> <p>Run frequency 2 seconds ...      Only integers are displayed when the frequency exceeds 100 Hz (Display example is 60 Hz)</p> <p>Output current 2 seconds ...      Only integers are displayed when the current exceeds 10 A (Display example is 1.6A)</p> <p>DC voltage of inverter 2 seconds ... (not output voltage)      Only the first and second digits are displayed (Display example is 270 V)</p> <p>Direction of the motor 2 seconds ...      F: Forward run r: reverse run</p> </div> <div data-bbox="603 1088 1031 1480"> <p>Operation frequency:      Fixed display</p> <p>Output current:      Fixed display</p> <p>Inverter DC voltage:      Fixed display</p> <p>Motor rotation direction: Fixed display</p> </div> <p data-bbox="284 1581 1026 1644">                         • When the ▲ or ▼ key is pressed in the 2-second interval automatic monitoring state, an optional monitor can display fixed values.                     </p> <div data-bbox="284 1659 1177 1861"> <p>2-second interval automatic monitoring (Any display is available.)</p> </div> <p data-bbox="292 1854 363 1888">[Stop]</p> <div data-bbox="427 1899 528 1989" style="border: 1px solid black; padding: 5px; display: inline-block;">000</div>	Possible to change during run



Command	Contents and display	Remarks
 Running direction setting	Set the motor direction. Set the motor direction when running by pressing  key.   Forward run   Reverse run	Im-possible to change during run
	Switching can be done by pressing   .	

Command	Contents and display	Remarks																																																																						
<div style="border: 1px solid black; display: inline-block; padding: 2px;"> <table border="1" style="font-size: 2em; text-align: center;"> <tr><td>V</td><td>F</td></tr> <tr><td>5</td><td>5</td></tr> </table> </div> <p>V/f pattern setting</p>	V	F	5	5	<p>This command sets V/F pattern.</p> <p>When combining V/F patterns other than the following using the control method (A0), the basic frequency (A62) and the maximum frequency (A63) of the extension function mode, the display shows <span style="border: 1px solid black; padding: 2px;">- - -</span>.</p> <table border="1" style="width: 100%; border-collapse: collapse;"> <thead> <tr> <th colspan="4">Output voltage</th> <th rowspan="3">V/F pattern</th> <th colspan="4">Output voltage</th> <th rowspan="3">V/F pattern</th> </tr> <tr> <th>200</th><th>220</th><th>230</th><th>240</th> <th>200</th><th>220</th><th>230</th><th>240</th> </tr> <tr> <th>380</th><th>400</th><th>440</th><th>460</th> <th>380</th><th>400</th><th>440</th><th>460</th> </tr> </thead> <tbody> <tr> <td>00</td><td>08</td><td>16</td><td>24</td> <td>  </td> <td>04</td><td>12</td><td>20</td><td>28</td> <td>  </td> </tr> <tr> <td>01</td><td>09</td><td>17</td><td>25</td> <td>  </td> <td>05</td><td>13</td><td>21</td><td>29</td> <td>  </td> </tr> <tr> <td>02</td><td>10</td><td>18</td><td>26</td> <td>  </td> <td>06</td><td>14</td><td>22</td><td>30</td> <td>  </td> </tr> <tr> <td>03</td><td>11</td><td>19</td><td>27</td> <td>  </td> <td>07</td><td>15</td><td>23</td><td>31</td> <td>  </td> </tr> </tbody> </table>	Output voltage				V/F pattern	Output voltage				V/F pattern	200	220	230	240	200	220	230	240	380	400	440	460	380	400	440	460	00	08	16	24		04	12	20	28		01	09	17	25		05	13	21	29		02	10	18	26		06	14	22	30		03	11	19	27		07	15	23	31		<p>Impossible to set during run</p>
V	F																																																																							
5	5																																																																							
Output voltage				V/F pattern	Output voltage				V/F pattern																																																															
200	220	230	240		200	220	230	240																																																																
380	400	440	460		380	400	440	460																																																																
00	08	16	24		04	12	20	28																																																																
01	09	17	25		05	13	21	29																																																																
02	10	18	26		06	14	22	30																																																																
03	11	19	27		07	15	23	31																																																																

Command	Contents and display	Remarks																							
	<p data-bbox="244 237 432 266">Special V/F pattern</p> <table border="1" data-bbox="236 286 703 909"> <thead> <tr> <th colspan="4" data-bbox="244 293 443 322">Output voltage</th> <th data-bbox="448 293 695 322" rowspan="2">V/F pattern</th> </tr> <tr> <th data-bbox="244 329 292 358">200</th> <th data-bbox="296 329 344 358">220</th> <th data-bbox="349 329 397 358">230</th> <th data-bbox="402 329 450 358">240</th> </tr> <tr> <th data-bbox="244 365 292 394">380</th> <th data-bbox="296 365 344 394">400</th> <th data-bbox="349 365 397 394">440</th> <th data-bbox="402 365 450 394">460</th> </tr> </thead> <tbody> <tr> <td data-bbox="244 495 292 524">50</td> <td data-bbox="296 495 344 524">51</td> <td data-bbox="349 495 397 524">52</td> <td data-bbox="402 495 450 524">53</td> <td data-bbox="448 405 695 629">  </td> </tr> <tr> <td data-bbox="244 759 292 788">54</td> <td data-bbox="296 759 344 788">55</td> <td data-bbox="349 759 397 788">56</td> <td data-bbox="402 759 450 788">57</td> <td data-bbox="448 669 695 893">  </td> </tr> </tbody> </table> <p data-bbox="722 371 1193 461">           Uses for V/F pattern            Constant torque characteristics : Conveyor            Reduced torque characteristics : Fan, pump         </p> <p data-bbox="276 949 1193 1028"> <b>NOTE:</b> When sensorless vector control (SLV1, SLV2) is selected as a control system and this command is changed in design, V/F control is forcibly selected. Be careful in this regard.         </p>	Output voltage				V/F pattern	200	220	230	240	380	400	440	460	50	51	52	53		54	55	56	57		
Output voltage				V/F pattern																					
200	220	230	240																						
380	400	440	460																						
50	51	52	53																						
54	55	56	57																						

Command	Contents and display	Remarks															
<p data-bbox="119 212 231 313">F 6</p> <p data-bbox="119 336 231 436">F 7</p> <p data-bbox="119 448 231 537">Acceleration time 1</p> <p data-bbox="119 560 231 649">Deceleration time 1</p>	<p data-bbox="263 212 1141 313">These commands set and display Acc. time (F 6) and Dec. time (F 7). In the case of adjustment in real time, press the  key after data is changed.</p> <div data-bbox="359 324 1101 459" style="text-align: center;"> </div> <table border="1" data-bbox="414 481 1037 616" style="margin-left: auto; margin-right: auto;"> <thead> <tr> <th>Setting range</th> <th>Period</th> </tr> </thead> <tbody> <tr> <td>0.1 to 99.9</td> <td>Every 0.1s</td> </tr> <tr> <td>100 to 999</td> <td>Every 1s</td> </tr> </tbody> </table> <p data-bbox="263 616 1133 694">• When a time of more than 999 seconds is set by the remote operator,  is displayed on the digital operator.</p>	Setting range	Period	0.1 to 99.9	Every 0.1s	100 to 999	Every 1s	Possible to set during run									
Setting range	Period																
0.1 to 99.9	Every 0.1s																
100 to 999	Every 1s																
<p data-bbox="119 739 231 840">F 8</p> <p data-bbox="119 862 231 974">Manual torque boost setting</p>	<p data-bbox="263 739 446 772">Set torque boost</p> <ul data-bbox="263 795 1189 996" style="list-style-type: none"> <li>• Motor torque can be adjusted to increase the output voltage when the starting torque is not sufficient in V/F control. Pay attention not to cause the motor to burnout and an inverter trip.</li> <li>• Setting is effective only when V/F control is selected.</li> <li>• In the case of adjustment in real time, press the  key after data is changed.</li> </ul> <div data-bbox="359 1019 558 1153" style="margin-left: 20px;"> <p>Code </p> <p style="margin-left: 40px;">}</p> <p></p> </div> <p data-bbox="359 1220 630 1288">Setting and changing is done with   keys.</p> <div data-bbox="734 1008 1141 1377" style="margin-left: 20px;"> <p>Output voltage 100%</p> <p>About 21</p> <p>0 5 25 50 Hz</p> <p style="margin-left: 10px;">6 30 60</p> </div>	Possible to set during run															
<p data-bbox="119 1411 231 1512">F 9</p> <p data-bbox="119 1534 231 1590">Running command</p> <p data-bbox="119 1612 231 1691">Frequency command setting</p>	<p data-bbox="263 1411 494 1444">Change setting mode</p> <table border="1" data-bbox="359 1467 1173 1758" style="margin-left: auto; margin-right: auto;"> <thead> <tr> <th></th> <th>Run command to</th> <th>Frequency command to (NOTE 1)</th> </tr> </thead> <tbody> <tr> <td></td> <td>Digital operator</td> <td>Digital operator</td> </tr> <tr> <td></td> <td>Digital operator</td> <td>Terminal block</td> </tr> <tr> <td></td> <td>Terminal block</td> <td>Digital operator</td> </tr> <tr> <td></td> <td>Terminal block</td> <td>Terminal block</td> </tr> </tbody> </table> <p data-bbox="263 1780 1212 1848"><b>NOTE 1:</b> The multi-speed output frequency can be set for one of  to .</p> <p data-bbox="375 1814 550 1848">(See page 8-8.)</p>		Run command to	Frequency command to (NOTE 1)		Digital operator	Digital operator		Digital operator	Terminal block		Terminal block	Digital operator		Terminal block	Terminal block	Impossible to set during run
	Run command to	Frequency command to (NOTE 1)															
	Digital operator	Digital operator															
	Digital operator	Terminal block															
	Terminal block	Digital operator															
	Terminal block	Terminal block															

Command	Contents and display	Remarks
<div data-bbox="135 226 233 309" style="border: 1px solid black; padding: 2px; display: inline-block;">F 10</div> Analog meter adjustment	<p data-bbox="268 226 1193 331">The voltage which is outputted to the [FM] monitor terminal can be adjusted. When the equipment starts running, <math>t/T</math> which is proportional to the output data is outputted between the terminals [FM] and [CM1]. Adjust the meter so that it indicates the highest point when the output is maximized.</p> <div data-bbox="331 338 1173 495" style="text-align: center;"> </div> <div data-bbox="619 517 1185 645" style="border: 1px solid black; padding: 5px; margin: 10px auto; width: fit-content;"> <p style="text-align: center;">Maximum level of analog meter</p> <p>Frequency monitor: Maximum frequency Current monitor: 200% of rated current of inverter</p> </div> <p data-bbox="316 663 1061 719"><b>NOTE:</b> This function is valid only when the analog monitor is used. (Analog frequency monitor, current monitor)</p>	Possible to set during run
<div data-bbox="135 770 233 853" style="border: 1px solid black; padding: 2px; display: inline-block;">F 11</div> Motor receiving voltage setting	<p data-bbox="268 770 837 819">The command sets the supply voltage for the motor. Set the supply voltage for the motor as shown below.</p> <div data-bbox="284 846 1161 1312" style="text-align: center;"> </div>	Impossible to set during run

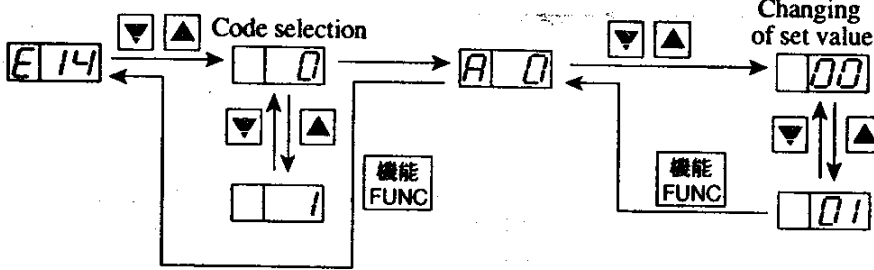
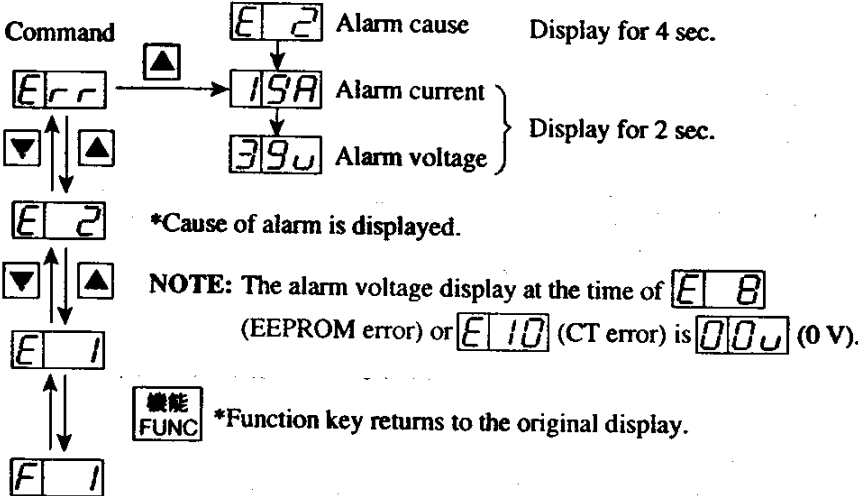

Command	Contents and display	Remarks
<p data-bbox="145 226 240 309">E 14</p> <p data-bbox="140 344 245 427">Extended function setting</p>	<p data-bbox="277 226 1182 367"><b>Setting of extended functions</b> The command selects the item of each extended function. When the setting ends, the screen is returned to the code display screen. When any data is changed, be sure to press the <b>機能 FUNC</b> key to store the new data</p>  <p data-bbox="277 667 1203 815"><b>NOTE:</b> During running, the code display of each extended function can be changed. However, each data setting of the extended functions cannot be changed. (However, the double acceleration and deceleration times <b>A 18</b> and <b>A 19</b> can be changed.)</p>	<p data-bbox="1219 277 1310 412"><b>NOTE:</b> Possible to set during run</p>
<p data-bbox="145 869 240 952">E r r</p> <p data-bbox="140 981 229 1064">Trip history monitor</p>	<p data-bbox="277 869 938 904"><b>Trip history monitor (Displays only when there is trip history)</b></p> <p data-bbox="277 920 724 956">Display method of monitoring trip history</p>  <p data-bbox="277 1518 1027 1554">• When the trip occurrence count is less than 3, <b>- - -</b> is displayed.</p>	<p data-bbox="1219 882 1310 994">Possible to check during run</p>

(2) Extension Function Mode

Command	Contents and display																								
<p><b>A 0</b></p> <p>Control method</p>	<p>This command sets a control method. Select one of the control codes shown below.</p> <p style="text-align: center;">▽ ▲ Initial set value</p> <p style="text-align: center;"> <span style="border: 1px solid black; padding: 2px;">A 0</span> ← → <span style="border: 1px solid black; padding: 2px;">  0</span> ..... V/f control (VC, VP1, VP2, VP3)         </p> <p style="text-align: center;"> <span style="border: 1px solid black; padding: 2px;">  1</span> ..... High starting torque (SLV1) for HITACHI general motors         </p> <p style="text-align: center;"> <span style="border: 1px solid black; padding: 2px;">  2</span> ..... High starting torque (SLV2) for dedicated general motors         </p> <p><b>Notes:</b></p> <ol style="list-style-type: none"> <li>The SLV2 control method has a mode for setting control constants such as motor constants. This mode requires a remote operator (DOP or DRW).</li> <li>If you change <span style="border: 1px solid black; padding: 2px;">F 5</span> (V/F Pattern Setting) after setting SLV1 or SLV2 with this command, the control method is forcibly reset to "V/f control."</li> </ol>																								
<p><b>A 1</b></p> <p><b>A 2</b></p> <p>Motor capacity</p> <p>Motor poles setting</p>	<p>This command sets the capacity and the number of poles of the motor. Maximum applicable ratings of 4-pole motors for each inverter are set initially.</p> <div style="display: flex; justify-content: space-around;"> <div style="text-align: center;"> <p><b>Motor capacity</b></p> <p style="border: 1px solid black; padding: 2px;">  5.5</p> <p>▽ ▲</p> <p style="border: 1px solid black; padding: 2px;">  4.0</p> <p>▽ ▲</p> <p style="border: 1px solid black; padding: 2px;">  3.7</p> <p>▽ ▲</p> <p style="border: 1px solid black; padding: 2px;">  2.2</p> <p>▽ ▲</p> <p style="border: 1px solid black; padding: 2px;">  1.5</p> <p>▽ ▲</p> <p style="border: 1px solid black; padding: 2px;">  1.1</p> <p>▽ ▲</p> <p style="border: 1px solid black; padding: 2px;">0.75</p> <p>▽ ▲</p> <p style="border: 1px solid black; padding: 2px;">0.55</p> <p>▽ ▲</p> <p style="border: 1px solid black; padding: 2px;">0.37</p> </div> <div style="text-align: center;"> <p><b>Number of poles</b></p> <p style="border: 1px solid black; padding: 2px;">  8</p> <p>▽ ▲</p> <p style="border: 1px solid black; padding: 2px;">  6</p> <p>▽ ▲</p> <p style="border: 1px solid black; padding: 2px;">  4</p> <p style="text-align: right;">Initial set value</p> <p>▽ ▲</p> <p style="border: 1px solid black; padding: 2px;">  2</p> </div> </div> <table border="1" style="margin-left: auto; margin-right: auto;"> <thead> <tr> <th>Model</th> <th><b>A 1</b></th> <th>Initial value</th> </tr> </thead> <tbody> <tr> <td>004SFES</td> <td style="border: 1px solid black; padding: 2px;">0.</td> <td style="border: 1px solid black; padding: 2px;">37</td> </tr> <tr> <td>007SFES</td> <td style="border: 1px solid black; padding: 2px;">0.</td> <td style="border: 1px solid black; padding: 2px;">75</td> </tr> <tr> <td>015SFES</td> <td style="border: 1px solid black; padding: 2px;">  </td> <td style="border: 1px solid black; padding: 2px;">1.5</td> </tr> <tr> <td>022SFES</td> <td style="border: 1px solid black; padding: 2px;">  </td> <td style="border: 1px solid black; padding: 2px;">2.2</td> </tr> <tr> <td>015HFES</td> <td style="border: 1px solid black; padding: 2px;">  </td> <td style="border: 1px solid black; padding: 2px;">1.5</td> </tr> <tr> <td>022HFES</td> <td style="border: 1px solid black; padding: 2px;">  </td> <td style="border: 1px solid black; padding: 2px;">2.2</td> </tr> <tr> <td>037HFES</td> <td style="border: 1px solid black; padding: 2px;">  </td> <td style="border: 1px solid black; padding: 2px;">4.0</td> </tr> </tbody> </table> <p><b>Notes:</b></p> <ol style="list-style-type: none"> <li>If the values set by this command are not fit for the motor running in the Sensorless Vector mode, the expected motor performance will not be obtained.</li> <li>In the sensorless vector operation, a motor whose ratings are lower than the maximum applicable ratings will not do its best performance.</li> <li>The sensorless vector function is not available for a simultaneous operation of two or more motors.</li> <li>If the rating for the motor in the V/f control mode is not the maximum applicable rating, set a correct rating for the motor.</li> </ol>	Model	<b>A 1</b>	Initial value	004SFES	0.	37	007SFES	0.	75	015SFES		1.5	022SFES		2.2	015HFES		1.5	022HFES		2.2	037HFES		4.0
Model	<b>A 1</b>	Initial value																							
004SFES	0.	37																							
007SFES	0.	75																							
015SFES		1.5																							
022SFES		2.2																							
015HFES		1.5																							
022HFES		2.2																							
037HFES		4.0																							

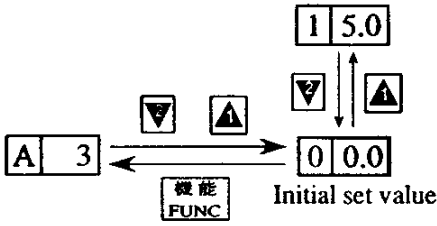
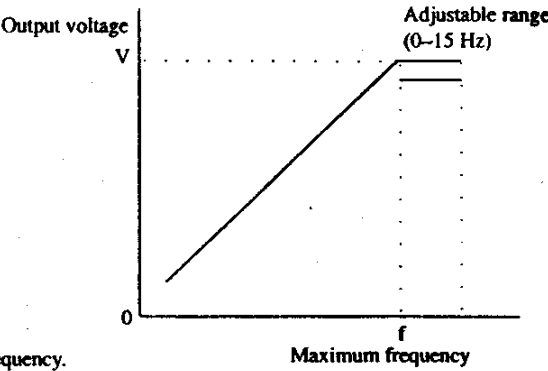
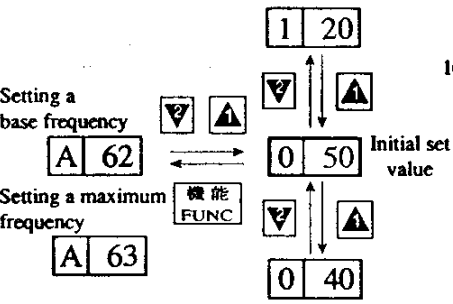
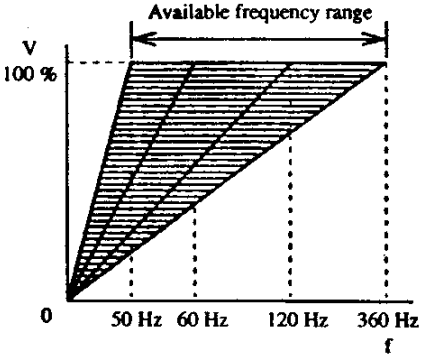
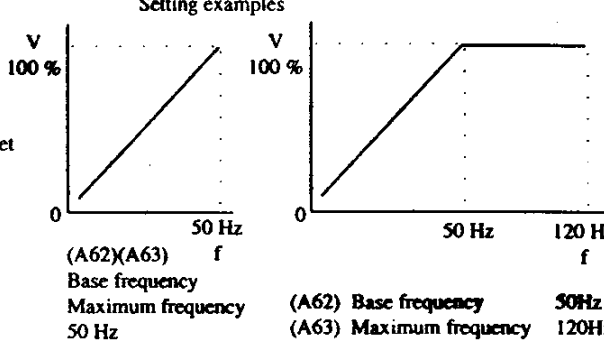
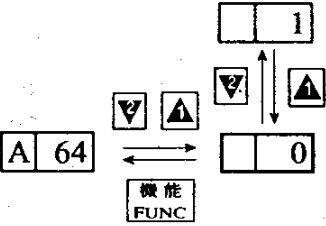
Command	Contents and display						
<p><b>A 3</b></p> <p>Maximum frequency adjustment</p>	<p>This command increases the maximum frequency at steps of 0.1Hz. Adjust the maximum frequency in the constant output range.</p>  <p>Note:</p> <ol style="list-style-type: none"> <li>1. Use the command <b>A 63</b> to set the maximum frequency.</li> </ol> 						
<p><b>A 62</b></p> <p><b>A 63</b></p> <p>Base frequency</p> <p>Maximum frequency setting</p>	<p>These commands set a base frequency <b>A 62</b> and a maximum frequency <b>A 63</b> respectively.</p>  <p>Setting a base frequency <b>A 62</b></p> <p>Setting a maximum frequency <b>A 63</b></p> <p>If the specified base frequency is greater than the specified maximum frequency, the system forcibly resets the base frequency to the maximum frequency at the start of operation and operates the motor with this frequency.</p>  <p>Setting examples</p>  <p>(A62)(A63) Base frequency 50 Hz Maximum frequency 50 Hz</p> <p>(A62) Base frequency 50 Hz (A63) Maximum frequency 120 Hz</p> <p>Notes:</p> <ol style="list-style-type: none"> <li>1. When a base frequency exceeding 60Hz is specified, the motor is used as a special-purpose motor (instead of a general-purpose motor). Accordingly, the maximum ratings of the motor vary and the capacity of the inverter must be increased even when the motor has the identical KW indication.</li> <li>2. Either the setting by this command or the setting by the <b>F 5</b> command (V/f Pattern Setting) which is specified last is used preferentially. When a V/f pattern is set by the <b>F 5</b> command after a base or maximum frequency is set by this command, the setting of the frequency is cancelled. Set the frequency again.</li> <li>3. When a base or maximum frequency exceeding 120Hz is set, the maximum frequency must be set to 360Hz by the <b>A 64</b> command.</li> <li>4. You can switch between the first and second settings of base frequencies, maximum frequencies, and control methods (V/f control or sensorless vector control) when they are stored. To use this function, you must store the first and second settings in advance. After switching to the control method (V/f control or sensorless vector control), the first or second setting, specify frequencies by the <b>A 62</b> and <b>A 63</b> commands. Data for the settings are stored.</li> <li>5. When a maximum frequency (by the <b>A 63</b> command) smaller than a base frequency (by the <b>A 62</b> command) is specified, the base frequency is changed.</li> </ol>						
<p><b>A 64</b></p> <p>Maximum frequency switching</p>	<p>This command changes the maximum frequency.</p>  <table border="1" data-bbox="805 1803 1157 1937"> <thead> <tr> <th>Set value</th> <th>Function</th> </tr> </thead> <tbody> <tr> <td>0</td> <td>120 Hz</td> </tr> <tr> <td>1</td> <td>360 Hz</td> </tr> </tbody> </table>	Set value	Function	0	120 Hz	1	360 Hz
Set value	Function						
0	120 Hz						
1	360 Hz						

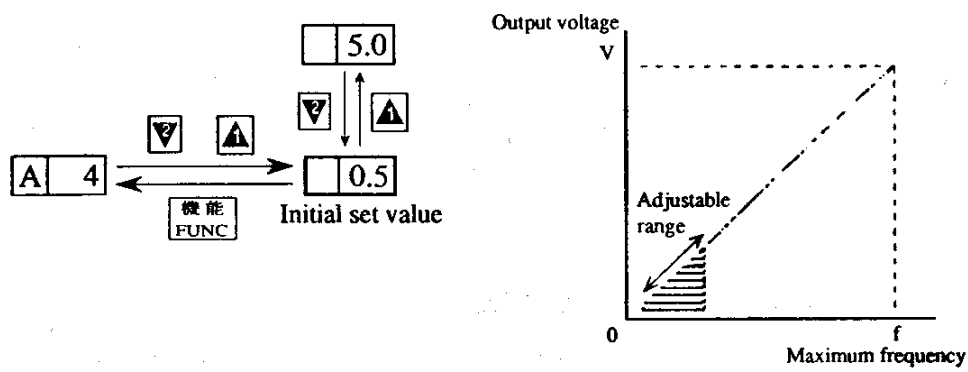
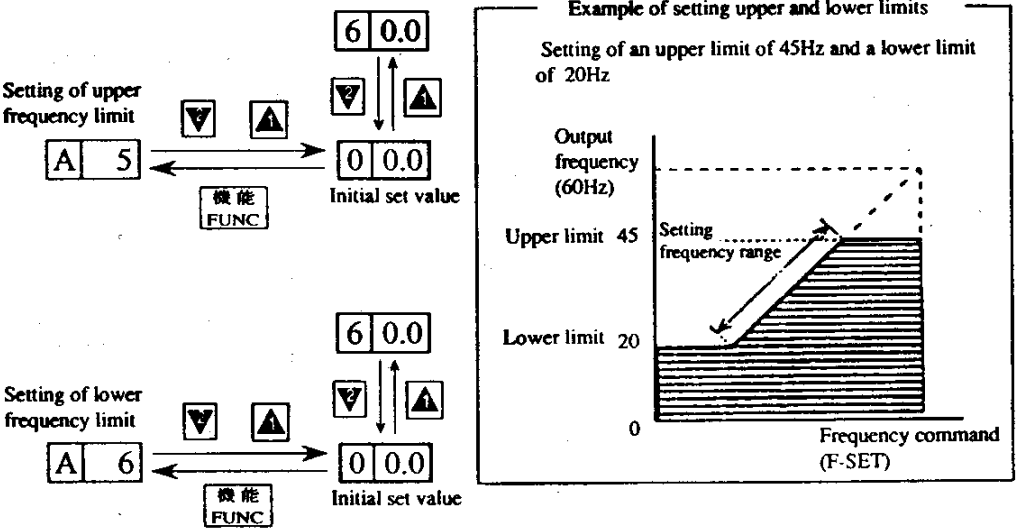
Command	Contents and display						
<p><b>A 4</b></p> <p>Start frequency adjustment</p>	<p>This command sets an inverter-output starting frequency. The frequency can be in the range of 0.5Hz to 5.0Hz (at steps of 0.1Hz).</p>  <p>Notes:</p> <ol style="list-style-type: none"> <li>1. The acceleration/deceleration time becomes shorter as the starting frequency goes higher.</li> <li>2. As the starting frequency goes higher, an overcurrent tripping is apt to occur.</li> </ol>						
<p><b>A 5</b></p> <p><b>A 6</b></p> <p>Frequency upper, lower limiter setting</p>	<p>These commands respectively set upper and lower limits to the frequencies specified by <b>A 4</b> (Start Frequency Adjustment), <b>A 63</b> (Maximum Frequency Setting), and <b>A 3</b> (Maximum Frequency Adjustment) commands.</p> <table border="1" data-bbox="255 952 566 1086"> <thead> <tr> <th>Setting range</th> <th>Step</th> </tr> </thead> <tbody> <tr> <td>0.0 ~ 99.9Hz</td> <td>0.1Hz</td> </tr> <tr> <td>100 ~ 375Hz</td> <td>1Hz</td> </tr> </tbody> </table> <p>Notes:</p> <ol style="list-style-type: none"> <li>1. When setting upper and lower limits, set an upper limit (by the <b>A 5</b> command) first.</li> <li>2. A value entered from the operator (ROP or DRW) will not be stored if it is over the upper limit or below the lower limit.</li> <li>3. When a value over the upper limit or below the lower limit is entered from a frequency command terminal (O, OI-L), the frequency will not change over the upper limit or below the lower limit.</li> <li>4. Limit setting condition. The specified limit values are valid only when the upper limit value is not smaller than the lower limit value. The upper and lower limits are not valid for a frequency of 0Hz.</li> </ol>  <p>Example of setting upper and lower limits</p> <p>Setting of an upper limit of 45Hz and a lower limit of 20Hz</p>	Setting range	Step	0.0 ~ 99.9Hz	0.1Hz	100 ~ 375Hz	1Hz
Setting range	Step						
0.0 ~ 99.9Hz	0.1Hz						
100 ~ 375Hz	1Hz						

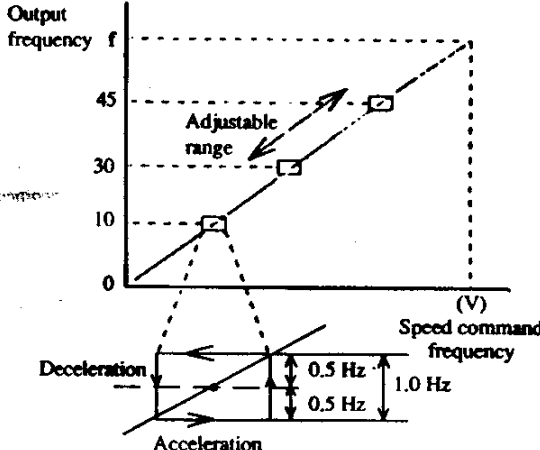
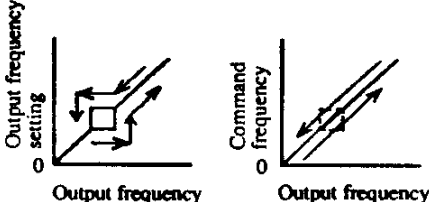
Command	Contents and display										
<p data-bbox="143 235 239 280">A 7</p> <p data-bbox="143 302 239 347">A 8</p> <p data-bbox="143 369 239 414">A 9</p> <p data-bbox="119 436 239 571">Jump frequency setting 1, 2, 3</p> <p data-bbox="143 772 239 817">A 68</p> <p data-bbox="119 851 239 985">Jump frequency range setting</p>	<p data-bbox="271 235 1316 347">These commands can jump a maximum of three frequencies to avoid unwanted resonances with loads. The frequencies to be jumped can be specified and executed in any order. To jump a frequency, specify the frequency and its allowance (<math>\pm</math> allowable frequency range).</p> <table border="1" data-bbox="279 369 590 504"> <tr> <th>Setting range</th> <th>Step</th> </tr> <tr> <td>0.0 ~ 99.9Hz</td> <td>0.1Hz</td> </tr> <tr> <td>100 ~ 375Hz</td> <td>1Hz</td> </tr> </table> <p data-bbox="798 392 989 425">Setting examples</p> <p data-bbox="949 425 1292 560">         Jump frequency 1: 10Hz          Jump frequency 2: 30Hz          Jump frequency 3: 45Hz          Jump frequency range: 0.5Hz       </p>  <p data-bbox="845 1019 1316 1075">When the jump frequency range of 0.5Hz is specified, a total frequency range of 1Hz is jumped.</p> <p data-bbox="845 1131 901 1153">Note:</p> <p data-bbox="845 1164 1316 1220">1. A frequency command value specified by a Jump Frequency Setting command is jumped.</p>  <p data-bbox="271 604 718 907">         Setting of jump frequency 1: A 7          Setting of jump frequency 2: A 8          Setting of jump frequency 3: A 9          Initial set value: 0 0.0          機能 FUNC       </p> <p data-bbox="271 1086 782 1332">         Setting of a jump frequency range: A 68          Initial set value: 0.5          機能 FUNC       </p>	Setting range	Step	0.0 ~ 99.9Hz	0.1Hz	100 ~ 375Hz	1Hz				
Setting range	Step										
0.0 ~ 99.9Hz	0.1Hz										
100 ~ 375Hz	1Hz										
<p data-bbox="143 1478 239 1523">A 10</p> <p data-bbox="119 1556 239 1657">Carrier frequency setting</p>	<p data-bbox="271 1467 1165 1512">This command sets a switching frequency (carrier frequency) of the power module.</p> <p data-bbox="790 1523 1300 1556">Select one of the following carrier frequencies:</p> <table border="1" data-bbox="877 1601 1292 1825"> <thead> <tr> <th>Set value</th> <th>Carrier frequency</th> </tr> </thead> <tbody> <tr> <td>16</td> <td>16 kHz</td> </tr> <tr> <td>12</td> <td>12 kHz</td> </tr> <tr> <td>8</td> <td>8 kHz</td> </tr> <tr> <td>5</td> <td>5kHz</td> </tr> </tbody> </table> <p data-bbox="271 1579 734 1803">         Setting: A 68          Initial set value: 16          機能 FUNC          05       </p> <p data-bbox="271 1892 327 1915">Notes:</p> <p data-bbox="271 1926 1220 2004">         1. When a smaller carrier frequency is selected, the magnetic noise of the motor becomes louder.          2. The carrier frequency is always 5kHz regardless of setting of this command in the D.C. Braking operation.       </p>	Set value	Carrier frequency	16	16 kHz	12	12 kHz	8	8 kHz	5	5kHz
Set value	Carrier frequency										
16	16 kHz										
12	12 kHz										
8	8 kHz										
5	5kHz										

Command	Contents and display						
<p><b>A 11</b></p> <p>Frequency command sampling setting</p>	<p>This command changes the effect of a filter to remove noises from an external analog frequency command. This command is used to increase the response ability of the external analog frequency command.</p> <div style="display: flex; align-items: center;"> <div style="margin-right: 20px;"> </div> <table border="1" style="border-collapse: collapse;"> <tr> <td>Set value</td> <td>1 ↔ 8</td> </tr> <tr> <td>Filter effect</td> <td>Small ↔ Large</td> </tr> <tr> <td>Response ability</td> <td>Quick ↔ Slow</td> </tr> </table> </div>	Set value	1 ↔ 8	Filter effect	Small ↔ Large	Response ability	Quick ↔ Slow
Set value	1 ↔ 8						
Filter effect	Small ↔ Large						
Response ability	Quick ↔ Slow						
<p><b>A 26</b></p> <p><b>A 27</b></p> <p>External frequency setting start</p> <p>External frequency setting end</p>	<p>These commands respectively set a frequency at which the inverter starts outputting in response to a frequency command (0 to 10V, 0 to 5V, 4 to 20mA) coming from the outside and a frequency at which the inverter stops outputting. When you specify 0Hz for these commands, this function is released.</p> <table border="1" style="border-collapse: collapse; margin-bottom: 10px;"> <thead> <tr> <th>Setting range</th> <th>Step</th> </tr> </thead> <tbody> <tr> <td>0.0 ~ 99.9Hz</td> <td>0.1Hz</td> </tr> <tr> <td>100 ~ 375Hz</td> <td>1Hz</td> </tr> </tbody> </table> <div style="display: flex;"> <div style="flex: 1;"> <p>Setting an output starting frequency</p> <p>Setting an output stopping frequency</p> <p><b>A 27</b> : Same as the above <b>A 26</b></p> </div> <div style="flex: 1;"> <p>Notes:</p> <ol style="list-style-type: none"> <li>The standard setting frequency is 0Hz.</li> <li>The settings by the <b>F 26</b> and <b>F 27</b> commands are cancelled when a maximum frequency is changed next. Set the start and end frequencies again by the <b>F 26</b> and <b>F 27</b> commands.</li> <li>When the valid starting and ending frequencies are specified and when the minimum frequency command (0V or 4mA) is entered, it sometimes happens that the output frequency may be 0.1 to 0.3Hz smaller than the frequency set by the <b>F 26</b> command.</li> </ol> <p>Setting examples</p> </div> </div>	Setting range	Step	0.0 ~ 99.9Hz	0.1Hz	100 ~ 375Hz	1Hz
Setting range	Step						
0.0 ~ 99.9Hz	0.1Hz						
100 ~ 375Hz	1Hz						
<p><b>A 48</b></p> <p>Analog input selection</p>	<p>This command changes a maximum voltage supplied to terminals O and L.</p> <div style="display: flex; align-items: center;"> <div style="margin-right: 20px;"> </div> <div> <p>Connection examples</p> </div> </div> <table border="1" style="border-collapse: collapse; margin-top: 10px;"> <thead> <tr> <th>Set value</th> <th>Function</th> </tr> </thead> <tbody> <tr> <td>0</td> <td>Inputs a maximum of 5V.</td> </tr> <tr> <td>1</td> <td>Inputs a maximum of 10V.</td> </tr> </tbody> </table>	Set value	Function	0	Inputs a maximum of 5V.	1	Inputs a maximum of 10V.
Set value	Function						
0	Inputs a maximum of 5V.						
1	Inputs a maximum of 10V.						

Command	Contents and display
---------	----------------------

- A 12
- A 13
- A 14
- A 15
- A 16
- A 17
- A 71

These commands set output frequencies for 1st to 7th speeds.  
 Each speed setting becomes valid when the intelligent input terminals [CF1], [CF2],[ CF3] to [PV24] are combined adequately.

Setting range	Step
0.0 ~ 99.9Hz	0.1Hz
100 ~ 375Hz	1Hz

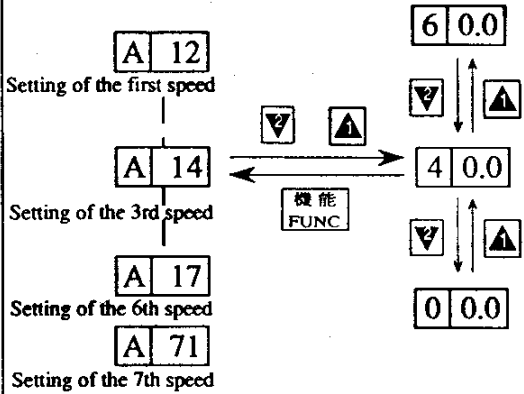

Multispeed  
 first  
 second  
 third  
 forth  
 fifth  
 sixth  
 seventh  
 speed  
 setting

Speed	Control circuit terminals			Expansion function code
	CF1	CF2	CF3	
1st	ON	OFF	OFF	A 12
2nd	OFF	ON	OFF	A 13
3rd	ON	ON	OFF	A 14
4th	ON	OFF	ON	A 15
5th	OFF	ON	ON	A 16
6th	ON	ON	ON	A 17
7th	OFF	OFF	ON	A 71

Note:

- When using multispeed commands of 4th to 7th, assign the multispeed terminal (CF3) to the input terminal.

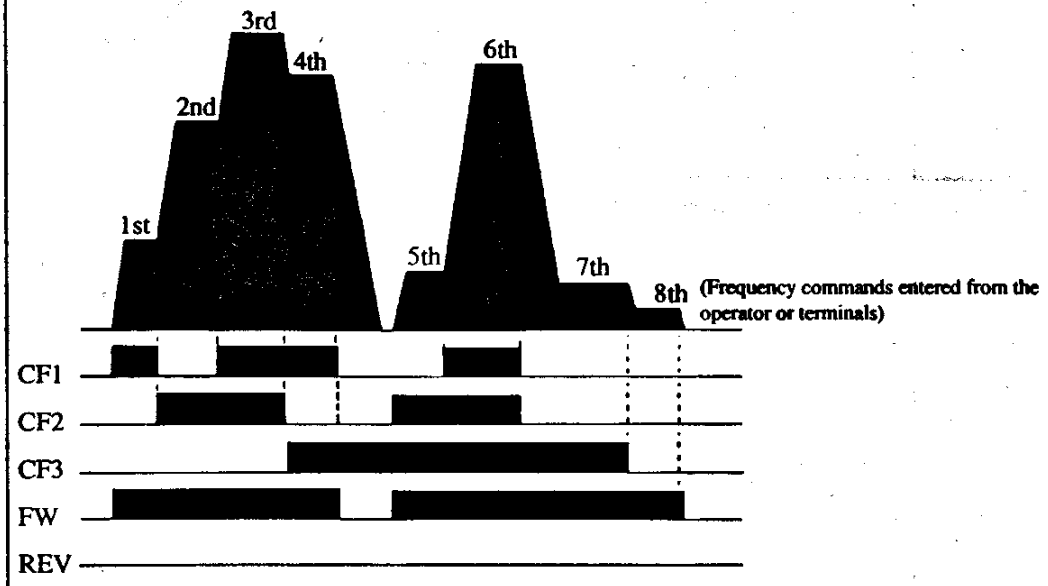

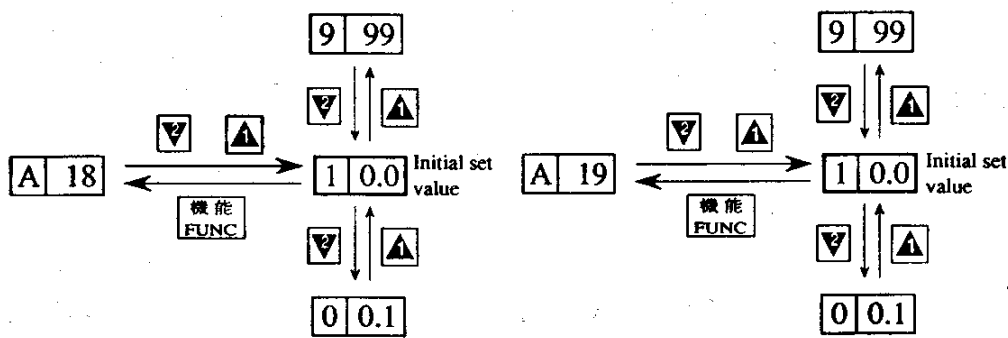
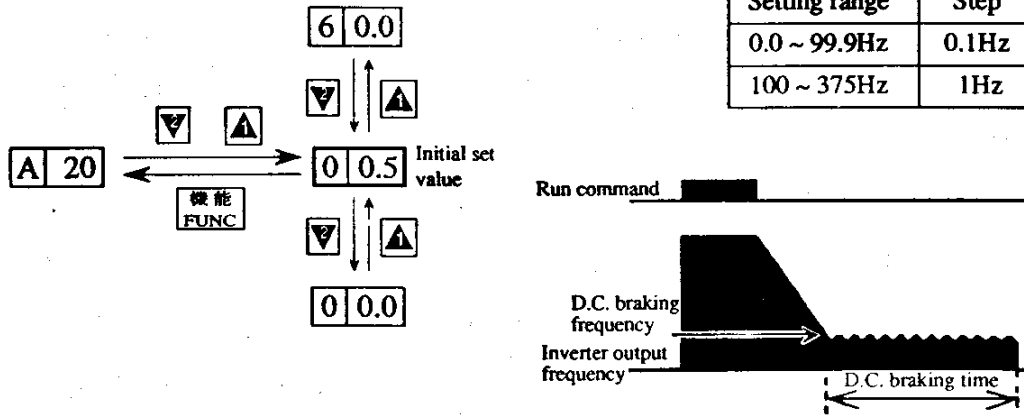
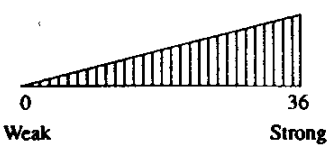
Command	Contents and display													
<p data-bbox="124 235 215 280">A 18</p> <p data-bbox="124 302 215 347">A 19</p> <p data-bbox="108 369 247 571">2-stage acceleration, deceleration time setting</p>	<p data-bbox="255 224 901 302">These commands respectively set a 2-step acceleration time <b>A 18</b> and a 2-step deceleration time <b>A 19</b>.</p> <table border="1" data-bbox="981 235 1284 369"> <thead> <tr> <th>Setting range</th> <th>Step</th> </tr> </thead> <tbody> <tr> <td>0.0 ~ 99.9 sec.</td> <td>0.1 sec.</td> </tr> <tr> <td>100 ~ 999 sec.</td> <td>1 sec.</td> </tr> </tbody> </table> 		Setting range	Step	0.0 ~ 99.9 sec.	0.1 sec.	100 ~ 999 sec.	1 sec.						
Setting range	Step													
0.0 ~ 99.9 sec.	0.1 sec.													
100 ~ 999 sec.	1 sec.													
<p data-bbox="124 795 215 840">A 20</p> <p data-bbox="124 862 215 907">A 21</p> <p data-bbox="124 929 215 974">A 22</p> <p data-bbox="108 985 231 1120">DC braking frequency setting</p> <p data-bbox="108 1142 231 1276">DC braking force adjustment</p> <p data-bbox="108 1299 231 1433">DC braking time adjustment</p>	<p data-bbox="255 784 973 862">The <b>A 20</b> command sets a frequency at which the D.C. braking operation starts.</p> <table border="1" data-bbox="997 851 1300 985"> <thead> <tr> <th>Setting range</th> <th>Step</th> </tr> </thead> <tbody> <tr> <td>0.0 ~ 99.9Hz</td> <td>0.1Hz</td> </tr> <tr> <td>100 ~ 375Hz</td> <td>1Hz</td> </tr> </tbody> </table>  <p data-bbox="255 1344 678 1422">The <b>A 21</b> command adjusts a D.C. braking force.</p> <p data-bbox="869 1344 1284 1422">The <b>A 22</b> command adjusts a D.C. braking time.</p>  <table border="1" data-bbox="997 1646 1300 1780"> <thead> <tr> <th>Setting range</th> <th>Step</th> </tr> </thead> <tbody> <tr> <td>0.0 ~ 99.9 sec.</td> <td>0.1 sec.</td> </tr> <tr> <td>100 ~ 600 sec.</td> <td>1 sec.</td> </tr> </tbody> </table> <p data-bbox="263 1859 327 1881">Notes:</p> <ol data-bbox="263 1892 1276 1982" style="list-style-type: none"> <li>During D.C. braking, an Overload Protection error (<b>E 5</b>) is apt to occur.</li> <li>The carrier frequency in the D.C. braking operation is always 5kHz regardless of the carrier frequency setting by <b>A 10</b>.</li> </ol>		Setting range	Step	0.0 ~ 99.9Hz	0.1Hz	100 ~ 375Hz	1Hz	Setting range	Step	0.0 ~ 99.9 sec.	0.1 sec.	100 ~ 600 sec.	1 sec.
Setting range	Step													
0.0 ~ 99.9Hz	0.1Hz													
100 ~ 375Hz	1Hz													
Setting range	Step													
0.0 ~ 99.9 sec.	0.1 sec.													
100 ~ 600 sec.	1 sec.													

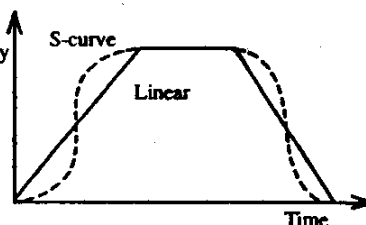
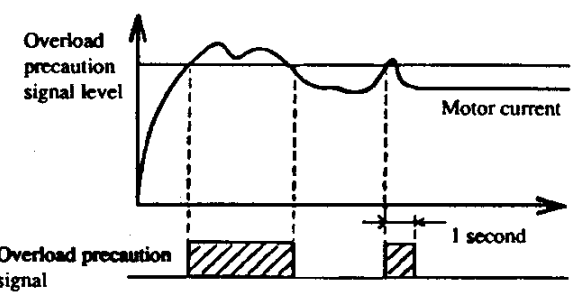
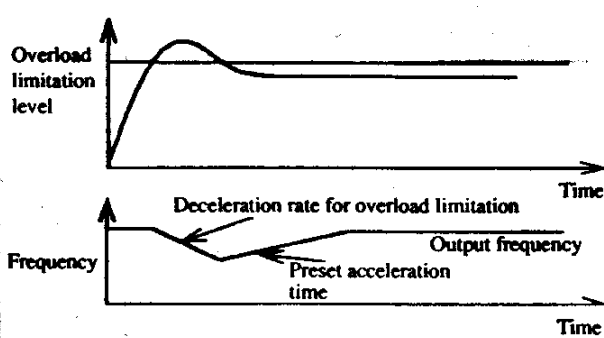

Command	Contents and display						
<p><b>A 55</b></p> <p>DC braking ON/OFF selection</p>	<p>This command enables (ON) or disables (OFF) a D.C. braking function.</p> <div style="display: flex; justify-content: space-around; align-items: center;"> <div style="text-align: center;"> </div> <div style="border: 1px solid black; padding: 5px;"> <table border="1"> <tr><th>Set value</th><th>Function</th></tr> <tr><td>0</td><td>OFF</td></tr> <tr><td>1</td><td>ON</td></tr> </table> </div> </div> <p>Initial set value</p> <p>Note: 1. Set "1" to use the D.C. braking function.</p>	Set value	Function	0	OFF	1	ON
Set value	Function						
0	OFF						
1	ON						
<p><b>A 56</b></p> <p>DC braking edge/level selection</p>	<p>This command selects a level of D.C. braking operation.</p> <div style="display: flex; justify-content: space-around; align-items: center;"> <div style="text-align: center;"> </div> <div style="border: 1px solid black; padding: 5px;"> <table border="1"> <tr><th>Set value</th><th>Function</th></tr> <tr><td>0</td><td>Edge operation</td></tr> <tr><td>1</td><td>Level operation</td></tr> </table> </div> </div> <p>Initial set value</p> <p>Braking time set by <b>A 22</b></p> <p>Edge operation      Level operation</p>	Set value	Function	0	Edge operation	1	Level operation
Set value	Function						
0	Edge operation						
1	Level operation						
<p><b>A 23</b></p> <p>Electronic thermal level adjustment</p>	<p>This command sets a level of an electronic thermal sensor. Set a thermal sensor level according to the rated current value of the motor.</p> <p>Notes:</p> <ol style="list-style-type: none"> <li>Even when a thermal level of more than 100% is set, do not operate the motor continuously with more than the rated current, or the life of the capacitor will shorten. If the ambient temperature rises, overheat of the motor will cause the power module protection and also will cause a trip.</li> <li>If the thermal level is greater than the rated current of the motor, the motor cannot be protected by the electronic thermal function. Use a thermal relay or the like to protect the motor against overloading.</li> </ol> <div style="border: 1px solid black; padding: 5px; margin: 10px 0;"> <math display="block">\text{Adjustable thermal level} = \frac{\text{Rated current of motor}}{\text{Rated current of inverter}} \times 100</math> </div> <div style="display: flex; justify-content: space-around; align-items: center;"> <div style="text-align: center;"> </div> <div> </div> </div>						
<p><b>A 24</b></p> <p>Electronic thermal characteristic selection</p>	<p>This command selects an electronic thermal characteristics. Set a thermal characteristic fit for the load.</p> <div style="display: flex; justify-content: space-around; align-items: center;"> <div style="text-align: center;"> </div> <div style="border: 1px solid black; padding: 5px;"> <table border="1"> <tr><th>Set value</th><th>Function</th></tr> <tr><td>0</td><td>Reduced torque characteristic</td></tr> <tr><td>1</td><td>Constant torque characteristic</td></tr> </table> </div> </div> <p>Initial set value</p>	Set value	Function	0	Reduced torque characteristic	1	Constant torque characteristic
Set value	Function						
0	Reduced torque characteristic						
1	Constant torque characteristic						

Command	Contents and display						
<p><b>A 28</b></p> <p><b>A 29</b></p> <p>Acceleration Deceleration (Linear, S-curve)</p>	<p>These commands respectively select liner or S-curve acceleration <b>A 28</b> and liner or S-curve deceleration. <b>A 29</b>.</p> <div style="display: flex; justify-content: space-around;"> <div style="text-align: center;"> <p>Selection of linear or S-curve acceleration</p> <p><b>A 28</b></p> <p>機能 FUNC</p> </div> <div style="text-align: center;"> <p>Initial set value</p> <p>0</p> </div> </div> <div style="display: flex; justify-content: space-around; margin-top: 10px;"> <div style="text-align: center;"> <p>Selection of linear or S-curve deceleration</p> <p><b>A 29</b></p> </div> <div style="text-align: center;"> <p>Initial set value</p> <p>1</p> </div> </div> <table border="1" style="margin-top: 10px;"> <thead> <tr> <th>Set value</th> <th>Function</th> </tr> </thead> <tbody> <tr> <td>0</td> <td>Linear</td> </tr> <tr> <td>1</td> <td>S-curve</td> </tr> </tbody> </table> 	Set value	Function	0	Linear	1	S-curve
Set value	Function						
0	Linear						
1	S-curve						
<p><b>A 30</b></p> <p>Overload signal</p>	<p>This command sets the ratio of the output level of the overload limiting signal to the rated current of the motor.</p> <div style="display: flex; justify-content: space-around;"> <div style="text-align: center;"> <p><b>A 30</b></p> <p>機能 FUNC</p> </div> <div style="text-align: center;"> <p>Initial set value</p> <p>1 50</p> </div> </div> <div style="display: flex; justify-content: space-around; margin-top: 10px;"> <div style="text-align: center;"> <p>0 50</p> </div> </div>  <p>Notes:</p> <ol style="list-style-type: none"> <li>The overload precaution signal is retained for at least one second.</li> <li>Set the <b>C 10</b> command to <b>2</b> and assign the Overload Precaution signal to the intelligent terminal.</li> </ol>						
<p><b>A 31</b></p> <p><b>A 85</b></p> <p>Overload limit level setting</p> <p>Deceleration rate setting for overload limit</p>	<p>These commands respectively set an overload limitation level <b>A 31</b> and a deceleration rate for overload limitation.</p> <div style="display: flex; justify-content: space-between;"> <div style="width: 45%;"> <p>Setting of an overload limitation level</p> <div style="display: flex; justify-content: space-around;"> <div style="text-align: center;"> <p><b>A 31</b></p> <p>機能 FUNC</p> </div> <div style="text-align: center;"> <p>Initial set value</p> <p>1 50</p> </div> </div> <div style="text-align: center; margin-top: 10px;"> <p>0 50</p> </div> </div> <div style="width: 45%;"> <p>Setting of a deceleration rate for overload limitation</p> <div style="display: flex; justify-content: space-around;"> <div style="text-align: center;"> <p><b>A 85</b></p> <p>機能 FUNC</p> </div> <div style="text-align: center;"> <p>Initial set value</p> <p>3 1.0</p> </div> </div> <div style="text-align: center; margin-top: 10px;"> <p>0 0.1</p> </div> </div> </div> <div style="margin-top: 20px;">  </div> <p>The Overload Limiting function reduces the output frequency and suppresses the output current when the motor is overloaded. Specify the overload limitation level and the deceleration rate, considering the load status and inertia of the machine used.</p>						

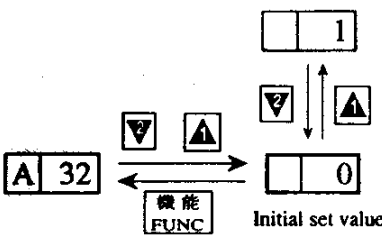
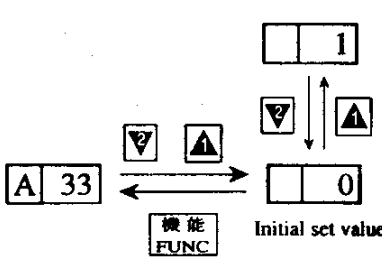
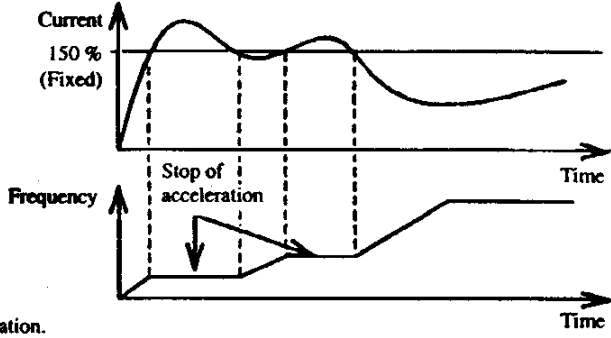
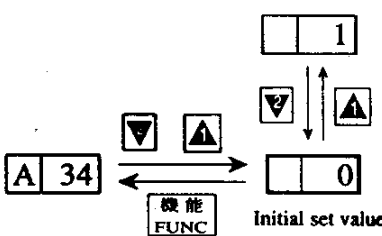
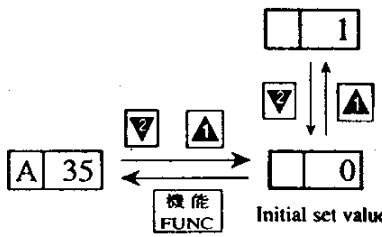
Command	Contents and display						
<p><b>A 32</b></p> <p>Overload limit content selection</p>	<p>This command sets the content of overload limitation.</p>  <table border="1" data-bbox="766 268 1324 414"> <thead> <tr> <th>Set value</th> <th>Condition of enabling the function</th> </tr> </thead> <tbody> <tr> <td>0</td> <td>Under acceleration and at constant speed</td> </tr> <tr> <td>1</td> <td>At constant speed only</td> </tr> </tbody> </table> <p>Note:</p> <ol style="list-style-type: none"> <li>The Overload Limitation function is disabled during deceleration.</li> </ol>	Set value	Condition of enabling the function	0	Under acceleration and at constant speed	1	At constant speed only
Set value	Condition of enabling the function						
0	Under acceleration and at constant speed						
1	At constant speed only						
<p><b>A 33</b></p> <p>LAD stop function setting</p>	<p>This command enables or disables the LAD Stop function.</p>  <table border="1" data-bbox="845 638 1300 772"> <thead> <tr> <th>Set value</th> <th>Function</th> </tr> </thead> <tbody> <tr> <td>0</td> <td>Enabled</td> </tr> <tr> <td>1</td> <td>Disabled</td> </tr> </tbody> </table>  <p>Note:</p> <ol style="list-style-type: none"> <li>This function is enabled also during deceleration.</li> </ol>	Set value	Function	0	Enabled	1	Disabled
Set value	Function						
0	Enabled						
1	Disabled						
<p><b>A 34</b></p> <p>Trip/retry function selection</p>	<p>This command selects a retry operation of the inverter when the inverter trips.</p>  <table border="1" data-bbox="782 1220 1316 1355"> <thead> <tr> <th>Set value</th> <th>Function</th> </tr> </thead> <tbody> <tr> <td>0</td> <td>Trips and outputs an alarm signal.</td> </tr> <tr> <td>1</td> <td>Restarts with a frequency of 0Hz.</td> </tr> </tbody> </table> <div data-bbox="782 1377 1316 1646" style="border: 1px solid black; padding: 5px;"> <p style="text-align: center;"><b>⚠ WARNING</b></p> <ul style="list-style-type: none"> <li>If the retry function is selected, it will suddenly restart during the alarm stop. Be sure not to approach the machine. (Be sure to design the machine so that personnel safety will be secured even if it restarts.)</li> </ul> </div> <p>Note:</p> <ol style="list-style-type: none"> <li>This function always restarts the inverter with a frequency of 0Hz.</li> </ol>	Set value	Function	0	Trips and outputs an alarm signal.	1	Restarts with a frequency of 0Hz.
Set value	Function						
0	Trips and outputs an alarm signal.						
1	Restarts with a frequency of 0Hz.						
<p><b>A 35</b></p> <p>Trip ignorance selection</p>	<p>This command enables or disables tripping by an undervoltage of the inverter when the inverter stops.</p>  <table border="1" data-bbox="758 1792 1324 1926"> <thead> <tr> <th>Set value</th> <th>Function</th> </tr> </thead> <tbody> <tr> <td>0</td> <td>Disables tripping by an undervoltage.</td> </tr> <tr> <td>1</td> <td>Enables tripping by an undervoltage.</td> </tr> </tbody> </table>	Set value	Function	0	Disables tripping by an undervoltage.	1	Enables tripping by an undervoltage.
Set value	Function						
0	Disables tripping by an undervoltage.						
1	Enables tripping by an undervoltage.						

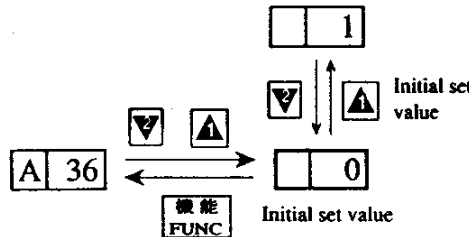
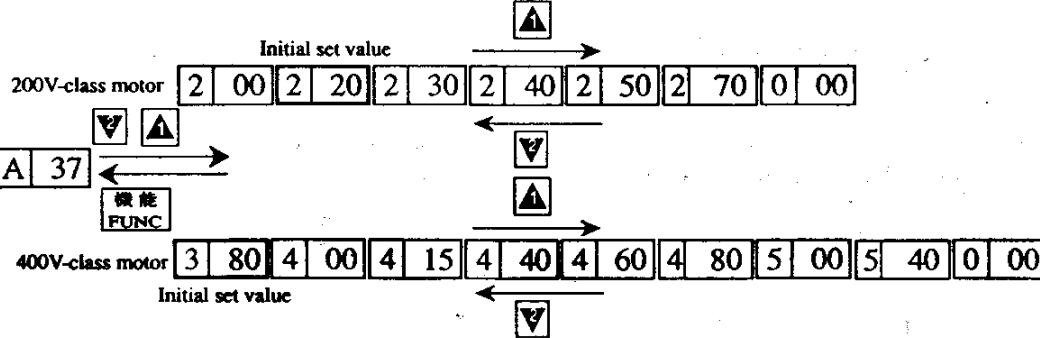
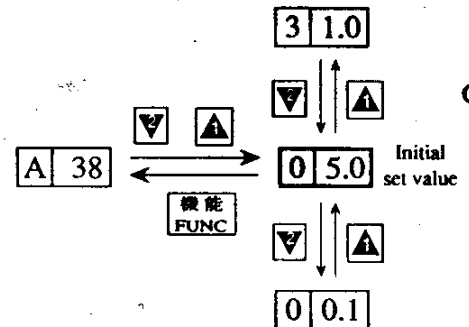
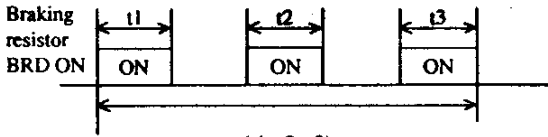
Command	Contents and display																
<p><b>A 36</b></p> <p>AVR setting for deceleration</p>	<p>This command selects a receiving voltage (AVR) of the motor during deceleration.</p>  <table border="1" data-bbox="726 324 1284 459"> <thead> <tr> <th>Set value</th> <th>Function</th> </tr> </thead> <tbody> <tr> <td>0</td> <td>AVR value equal to a value set by <b>E 5</b></td> </tr> <tr> <td>1</td> <td>Any AVR value set by <b>A 37</b>.</td> </tr> </tbody> </table> <p>* To increase the regenerative torque of the decelerated motor, set this command to "1" and increase the value of <b>A 37</b> or reset the <b>A 37</b> value to <b>0 00</b>. In this situation, if the Overvoltage Protection error (<b>E 7</b>) occurs, use an external regenerative braking resistor.</p>	Set value	Function	0	AVR value equal to a value set by <b>E 5</b>	1	Any AVR value set by <b>A 37</b> .										
Set value	Function																
0	AVR value equal to a value set by <b>E 5</b>																
1	Any AVR value set by <b>A 37</b> .																
<p><b>A 37</b></p> <p>Motor voltage setting for deceleration</p>	<p>This command sets the receiving voltage of the decelerated motor. Set the receiving voltage of the decelerated motor as shown below.</p>  <p>When a value <b>0 00</b> is set, the AVR function is disabled during deceleration.</p>																
<p><b>A 38</b></p> <p>Dynamic braking usage ratio</p>	<p>This command sets the rate of use (in percentage) of the regenerative braking resistor for 100 seconds.</p> <p>When the resistor is used more than this rate, the Braking Resistor Overload Trip error <b>E 6</b> occurs.</p>  <p>Content of the function</p>  $T = \frac{(t1+t2+t3)}{100 \text{ seconds}} \times 100$ <p>Notes:</p> <ol style="list-style-type: none"> <li>When a rate of 31.0% is specified, the braking resistor (BRD) function is disabled.</li> <li>When the value T exceeds a preset value, the BRD function</li> <li>When an external resistor is used, its resistance must not be smaller than the minimum resistance shown below. The wire between the external resistor and the inverter should be a maximum of 5 meters long.</li> </ol> <table border="1" data-bbox="247 1881 1252 1993"> <thead> <tr> <th>Model</th> <th>004SFE3</th> <th>007SFE3</th> <th>015SFE3</th> <th>022SFE3</th> <th>015HFE3</th> <th>022HFE3</th> <th>037HFE3</th> </tr> </thead> <tbody> <tr> <td>Minimum resistance</td> <td>100 Ω</td> <td>35 Ω</td> <td>35 Ω</td> <td>35 Ω</td> <td>180 Ω</td> <td>100 Ω</td> <td>100 Ω</td> </tr> </tbody> </table>	Model	004SFE3	007SFE3	015SFE3	022SFE3	015HFE3	022HFE3	037HFE3	Minimum resistance	100 Ω	35 Ω	35 Ω	35 Ω	180 Ω	100 Ω	100 Ω
Model	004SFE3	007SFE3	015SFE3	022SFE3	015HFE3	022HFE3	037HFE3										
Minimum resistance	100 Ω	35 Ω	35 Ω	35 Ω	180 Ω	100 Ω	100 Ω										

**A 39**  
**A 40**

These commands respectively set the frequency of the output signal when the motor is accelerated **A 39** and the frequency of the output signal when the motor is decelerated **A 40** (at steps of 1%). These commands are valid when **1** or **2** is selected for the **A 49** command (Frequency Arrival Signal Output Method).

Optional arrival frequency for acceleration, deceleration

Setting of the frequency of the output signal (for acceleration) **A 39** → Initial set value **1 00**  
 ↓ ↑  
 機能 FUNC  
**0 00**

Setting of the frequency of the output signal (for deceleration) **A 40** : Same as the above **A 39**

Note:  
 1. In case the specified acceleration arrival frequency is equal to or less than the specified deceleration arrival frequency or the difference between the specified acceleration and deceleration arrival frequencies is very small, the arrival signal may chatter when an analog frequency command is given.

**A 49**

Frequency arrival signal output method

This command selects a method of outputting a frequency arrival signal when the signal is selected for the output terminal.

**A 49** → Initial set value **2**  
 ↓ ↑  
 機能 FUNC  
**1**

Set value	Function
1	Frequency setting or more
2	Setting frequency arrival (at constant speed)

The frequency for the A49 value of "1" can be specified by the **A 39** (Acceleration) or **A 40** (Deceleration) command.

Note:  
 1. Set the **C 10** command to **0** and assign the Frequency Arrival signal to the intelligent terminal.

**A 41**  
**A 42**

Forward rotation  
Reverse rotation

These commands respectively specify forward rotation **A 41** and reverse rotation **A 42**.

Specification of forward rotation **A 41** → Initial set value **1**  
 ↓ ↑  
 機能 FUNC  
**0**

Specification of backward rotation **A 42** : Same as the above **A 41**

Set value	Function
0	Disables rotation in the specified direction.
1	Enables rotation in the specified direction.

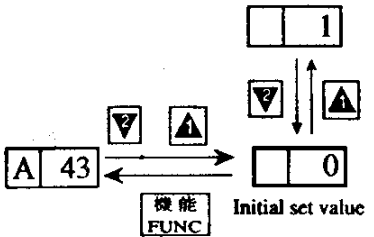
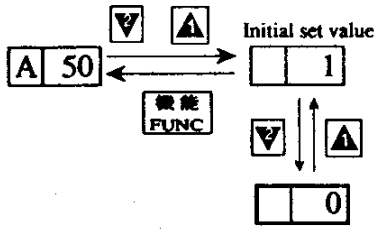
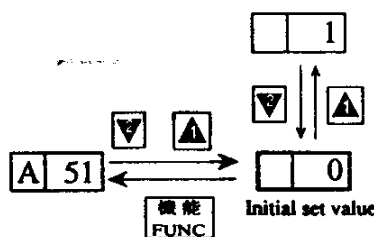
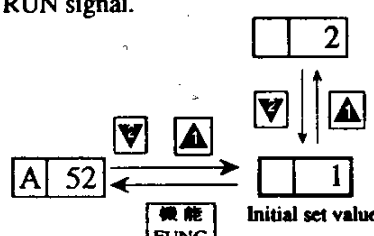
Command	Contents and display						
<p><b>A 43</b></p> <p>Stop key ON/OFF selection</p>	<p>This command enables or disables the STOP key function of the digital or remote operator when a run command is sent to the terminal board.</p>  <table border="1" data-bbox="973 347 1244 504"> <thead> <tr> <th>Set value</th> <th>Function</th> </tr> </thead> <tbody> <tr> <td>0</td> <td>Enable</td> </tr> <tr> <td>1</td> <td>Disable</td> </tr> </tbody> </table> <p>Initial set value</p> <div style="border: 1px solid black; padding: 5px; text-align: center;"> <p><b>! WARNING</b></p> <ul style="list-style-type: none"> <li>When the Stop key function is ineffective, pressing the Stop key does not cancel the stop and trip. Be sure to provide an emergency stop switch separately. When the operation command destination is a digital operator, this selection is ineffective.</li> </ul> </div>	Set value	Function	0	Enable	1	Disable
Set value	Function						
0	Enable						
1	Disable						
<p><b>A 50</b></p> <p>Analog/digital meter selection</p>	<p>This command changes a monitor's method of outputting to the terminals FM and CMI.</p>  <table border="1" data-bbox="790 940 1204 1086"> <thead> <tr> <th>Set value</th> <th>Function</th> </tr> </thead> <tbody> <tr> <td>0</td> <td>for the digital meter</td> </tr> <tr> <td>1</td> <td>for the analog meter</td> </tr> </tbody> </table> <p>Initial set value</p>	Set value	Function	0	for the digital meter	1	for the analog meter
Set value	Function						
0	for the digital meter						
1	for the analog meter						
<p><b>A 51</b></p> <p>Frequency Current monitoring selection</p>	<p>This command changes a type of monitor which outputs to the terminals FM and CMI.</p>  <table border="1" data-bbox="790 1288 1204 1433"> <thead> <tr> <th>Set value</th> <th>Function</th> </tr> </thead> <tbody> <tr> <td>0</td> <td>Frequency monitor</td> </tr> <tr> <td>1</td> <td>Current monitor</td> </tr> </tbody> </table> <p>Initial set value</p>	Set value	Function	0	Frequency monitor	1	Current monitor
Set value	Function						
0	Frequency monitor						
1	Current monitor						
<p><b>A 52</b></p> <p>Run signal output selection</p>	<p>This command selects an output mode of the RUN signal when the output terminals select the RUN signal.</p>  <table border="1" data-bbox="782 1668 1276 1848"> <thead> <tr> <th>Set value</th> <th>Function</th> </tr> </thead> <tbody> <tr> <td>1</td> <td>Outputting during running</td> </tr> <tr> <td>2</td> <td>Outputting during running and during D.C. braking</td> </tr> </tbody> </table> <p>Initial set value</p> <p>Note:</p> <p>1. Set the <b>C 10</b> command to <b>1</b> and assign the RUN signal to the intelligent terminal.</p>	Set value	Function	1	Outputting during running	2	Outputting during running and during D.C. braking
Set value	Function						
1	Outputting during running						
2	Outputting during running and during D.C. braking						

Command	Contents and display						
<p data-bbox="151 235 247 280"><b>A 53</b></p> <p data-bbox="135 302 263 526">Enables/ disables change of frequency setting in the soft lock status</p>	<p data-bbox="284 235 1236 268">This command enables or disables change of a frequency setting in the Soft Lock status.</p> <div data-bbox="295 291 662 526"> <table border="1" data-bbox="813 324 1300 459"> <thead> <tr> <th>Set value</th> <th>Function</th> </tr> </thead> <tbody> <tr> <td>0</td> <td>Enables change of setting.</td> </tr> <tr> <td>1</td> <td>Disables change of setting.</td> </tr> </tbody> </table> </div>	Set value	Function	0	Enables change of setting.	1	Disables change of setting.
Set value	Function						
0	Enables change of setting.						
1	Disables change of setting.						
<p data-bbox="151 683 247 728"><b>A 57</b></p> <p data-bbox="135 750 263 840">Trip history clear selection</p>	<p data-bbox="284 683 1268 772">This command is used to clear the history of tripping. After setting "1" for this command, turn off and on power or connect and disconnect the RS (Reset) terminal. The history of tripping is cleared.</p> <div data-bbox="295 828 662 1064"> <table border="1" data-bbox="798 884 1292 1019"> <thead> <tr> <th>Set value</th> <th>Function</th> </tr> </thead> <tbody> <tr> <td>0</td> <td>Counts trippings.</td> </tr> <tr> <td>1</td> <td>Clears the history of tripping.</td> </tr> </tbody> </table> </div>	Set value	Function	0	Counts trippings.	1	Clears the history of tripping.
Set value	Function						
0	Counts trippings.						
1	Clears the history of tripping.						
<p data-bbox="151 1097 247 1142"><b>A 58</b></p> <p data-bbox="135 1176 263 1299">Reduced voltage start selection</p>	<p data-bbox="284 1097 1292 1220">This command enables or disables soft-start of a reduced voltage. Set "0" (Disables soft-start with reduced voltage) for this command to make the start response quicker. In this situation, an Overcurrent Protection error is apt to occur. Accordingly, when a starting torque is required (e.g. because of a heavy load, etc.), set "1" for this command.</p> <div data-bbox="295 1254 662 1478"> <table border="1" data-bbox="798 1332 1292 1523"> <thead> <tr> <th>Set value</th> <th>Function</th> </tr> </thead> <tbody> <tr> <td>0</td> <td>Disables soft-start with reduced voltage.</td> </tr> <tr> <td>1</td> <td>Enables soft-start with reduced voltage.</td> </tr> </tbody> </table> </div> <div data-bbox="279 1579 1316 1960"> <p data-bbox="869 1713 1316 1848">     ----- Setting of "Disables soft-start with reduced voltage."      ——— Setting of "Enables soft-start with reduced voltage."   </p> </div>	Set value	Function	0	Disables soft-start with reduced voltage.	1	Enables soft-start with reduced voltage.
Set value	Function						
0	Disables soft-start with reduced voltage.						
1	Enables soft-start with reduced voltage.						

Command	Contents and display
<p data-bbox="124 248 225 342"> <input type="text" value="A"/> <input type="text" value="80"/>  <input type="text" value="A"/> <input type="text" value="81"/> </p> <p data-bbox="108 371 225 533">           Frequency command adjust (voltage, current)         </p>	<p data-bbox="256 241 1251 309">           These commands adjust the relationship between external frequency commands and inverter output frequencies.         </p> <p data-bbox="284 349 695 389"> <input type="text" value="A"/> <input type="text" value="80"/> : Voltage command (O-L)         </p> <p data-bbox="284 407 703 448"> <input type="text" value="A"/> <input type="text" value="81"/> : Current command (OI-L)         </p> <p data-bbox="256 481 1299 611">           It is not recommended to use this function so often. If this function is used so often, the relationship between external frequency commands and inverter output frequencies is broken and the control function is disabled. Use this function only when the external commands are not related to output frequencies adequately.         </p> <p data-bbox="284 640 1265 707">           In case the output frequency is smaller than the external command, increase the data value.            In case the output frequency is greater than the external command, decrease the data value.         </p>
<p data-bbox="124 734 225 828"> <input type="text" value="A"/> <input type="text" value="82"/>  <input type="text" value="A"/> <input type="text" value="83"/> </p> <p data-bbox="108 862 225 1149">           Allowable under voltage time, Under voltage retry waiting time setting         </p>	<p data-bbox="256 730 1283 797">           These commands respectively set an allowance time of an undervoltage and a reentry wait time after power recovery.         </p> <div data-bbox="264 824 1267 1137" style="display: flex; justify-content: space-around;"> <div style="text-align: center;"> <p data-bbox="264 958 352 999"> <input type="text" value="A"/> <input type="text" value="82"/> </p> <p data-bbox="368 920 628 1137"> </p> </div> <div style="text-align: center;"> <p data-bbox="783 958 871 999"> <input type="text" value="A"/> <input type="text" value="83"/> </p> <p data-bbox="887 824 1147 1137"> </p> </div> </div> <p data-bbox="256 1160 743 1413">           An undervoltage event occurs when power is shut off or the voltage falls under a preset value while the inverter is in service. When the undervoltage event ends within a preset time period, the inverter can be restarted. (When the under-voltage event lasts over the preset time period, tripping occurs with the Undervoltage Protection error.)         </p> <p data-bbox="804 1160 1299 1227">           A preset reentry wait time later after power is recovered, retrying starts.         </p> <div data-bbox="256 1435 1147 1899" style="margin-top: 20px;"> <p data-bbox="603 1435 919 1469" style="text-align: center;">Allowable undervoltage time</p> </div> <p data-bbox="256 1921 312 1951"> <b>Note:</b> </p> <p data-bbox="256 1957 1023 1989">           1. To use the retry function, set the <input type="text" value="A"/> <input type="text" value="34"/> command to <input type="text" value=""/> <input type="text" value="1"/> (Restart with 0Hz).         </p>



Command

Contents and display

A 84

This command enables or disables rewriting of data.

Software lock selection

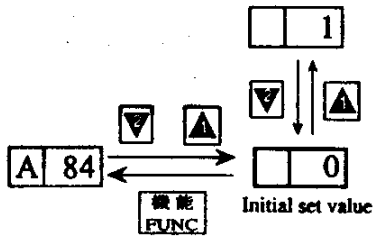

Initial set value

Set value	Function
0	Enables rewriting.
1	Disables rewriting.

soft lock

Note:

1. When you operate the ▲ or ▼ key on the operator in the Soft-Lock status, data on the display changes but will neither be changed nor stored.

Command	Contents and display																																																																																						
C 0 ? C 4	<p>These commands respectively assign terminal functions to terminals 1 to 5 (a total of five terminals).</p> <p>When changing the initial functions assigned to the terminals or changing the order of the terminals, reassign the functions respectively to the terminals by these commands.</p> <p>The time to input a signal to an input intelligent terminal should be 12 msec or more.</p> <p>Assignment of commands to intelligent terminals</p> <table border="1" data-bbox="263 443 853 683"> <thead> <tr> <th>Command</th> <th>Name of function</th> <th>Terminal symbol</th> <th>Initial value</th> </tr> </thead> <tbody> <tr> <td>C 0</td> <td>Input terminal setting 1</td> <td>1</td> <td>1</td> </tr> <tr> <td>C 1</td> <td>Input terminal setting 2</td> <td>2</td> <td>2</td> </tr> <tr> <td>C 2</td> <td>Input terminal setting 3</td> <td>3</td> <td>7</td> </tr> <tr> <td>C 3</td> <td>Input terminal setting 4</td> <td>4</td> <td>11</td> </tr> <tr> <td>C 4</td> <td>Input terminal setting 5</td> <td>5</td> <td>0</td> </tr> </tbody> </table> <div style="display: flex; justify-content: space-around; margin-top: 10px;"> <div style="text-align: center;"> <p>Input intelligent terminals</p> <table border="1" style="border-collapse: collapse;"> <tr> <td>3</td><td>2</td><td>1</td><td>PV24</td><td>FW</td> </tr> <tr> <td>H</td><td>O</td><td>OI</td><td>L</td><td>FM</td> </tr> </table> </div> <div style="text-align: center;"> <p>Input intelligent terminals</p> <table border="1" style="border-collapse: collapse;"> <tr> <td>5</td><td>4</td><td>CM1</td><td>CM1</td><td>AL0</td> </tr> <tr> <td>CM2</td><td>11</td><td></td><td>AL2</td><td>AL1</td> </tr> </table> </div> </div> <p>Setting procedure</p> <ul style="list-style-type: none"> <li>- Press the  or  key once for a desired terminal setting command.</li> <li>- The preset value of the terminal is displayed. Press the  or  key repeatedly until the desired value appears on the display (in reference with the List of Functions), then press the  key.</li> <li>- Return to the command display status and make sure that a new terminal function has been assigned.</li> </ul> <div style="border: 1px solid black; padding: 5px; margin-top: 10px;"> <p><b>Setting example:</b> Assigning the SFT (Terminal Soft Lock) function to the RS (Reset) terminal</p> <p style="text-align: center;">Enter the value of a desired terminal by pressing the  or  key. </p> <div style="display: flex; align-items: center; justify-content: center; gap: 20px;"> <div style="border: 1px solid black; padding: 2px 5px;">C 0</div> <div style="font-size: 2em;">→</div> <div style="border: 1px solid black; padding: 2px 5px;">11</div> <div style="font-size: 2em;">→</div> <div style="border: 1px solid black; padding: 2px 5px;">12</div> <div style="font-size: 2em;">→</div> <div style="border: 1px solid black; padding: 2px 5px;">C 0</div> </div> </div> <p>List of Terminal Functions</p> <table border="1" data-bbox="279 1205 912 1796"> <thead> <tr> <th>Set value</th> <th>Symbol</th> <th>Name of function</th> </tr> </thead> <tbody> <tr><td>0</td><td>REV</td><td>Backward rotation</td></tr> <tr><td>1</td><td>CF 1</td><td>Speed 1</td></tr> <tr><td>2</td><td>CF 2</td><td>Speed 2</td></tr> <tr><td>3</td><td>CF 3</td><td>Speed 3</td></tr> <tr><td>4</td><td>DB</td><td>External D.C. braking</td></tr> <tr><td>5</td><td>STN</td><td>Initial setting</td></tr> <tr><td>6</td><td>SET</td><td>Secondary setting function</td></tr> <tr><td>7</td><td>2CH</td><td>2-step acceleration/deceleration</td></tr> <tr><td>8</td><td>FRS</td><td>Free-running stop</td></tr> <tr><td>9</td><td>EXT</td><td>External tripping</td></tr> <tr><td>10</td><td>USP</td><td>USP function</td></tr> <tr><td>11</td><td>RS</td><td>Resetting</td></tr> <tr><td>12</td><td>SFT</td><td>Terminal Soft Lock</td></tr> </tbody> </table> <p>Notes on terminal setting</p> <ul style="list-style-type: none"> <li>- Do not enter identical values for C 0 to C 4 commands.</li> <li>- When moving a terminal function from a terminal to another terminal, first assign a set value of a terminal function to a terminal from which its function is moved, then assign the value of a function to be moved to the destination terminal. (Do not enter a value of the function to the destination terminal first.)</li> </ul>	Command	Name of function	Terminal symbol	Initial value	C 0	Input terminal setting 1	1	1	C 1	Input terminal setting 2	2	2	C 2	Input terminal setting 3	3	7	C 3	Input terminal setting 4	4	11	C 4	Input terminal setting 5	5	0	3	2	1	PV24	FW	H	O	OI	L	FM	5	4	CM1	CM1	AL0	CM2	11		AL2	AL1	Set value	Symbol	Name of function	0	REV	Backward rotation	1	CF 1	Speed 1	2	CF 2	Speed 2	3	CF 3	Speed 3	4	DB	External D.C. braking	5	STN	Initial setting	6	SET	Secondary setting function	7	2CH	2-step acceleration/deceleration	8	FRS	Free-running stop	9	EXT	External tripping	10	USP	USP function	11	RS	Resetting	12	SFT	Terminal Soft Lock
Command	Name of function	Terminal symbol	Initial value																																																																																				
C 0	Input terminal setting 1	1	1																																																																																				
C 1	Input terminal setting 2	2	2																																																																																				
C 2	Input terminal setting 3	3	7																																																																																				
C 3	Input terminal setting 4	4	11																																																																																				
C 4	Input terminal setting 5	5	0																																																																																				
3	2	1	PV24	FW																																																																																			
H	O	OI	L	FM																																																																																			
5	4	CM1	CM1	AL0																																																																																			
CM2	11		AL2	AL1																																																																																			
Set value	Symbol	Name of function																																																																																					
0	REV	Backward rotation																																																																																					
1	CF 1	Speed 1																																																																																					
2	CF 2	Speed 2																																																																																					
3	CF 3	Speed 3																																																																																					
4	DB	External D.C. braking																																																																																					
5	STN	Initial setting																																																																																					
6	SET	Secondary setting function																																																																																					
7	2CH	2-step acceleration/deceleration																																																																																					
8	FRS	Free-running stop																																																																																					
9	EXT	External tripping																																																																																					
10	USP	USP function																																																																																					
11	RS	Resetting																																																																																					
12	SFT	Terminal Soft Lock																																																																																					

Command

Contents and display

C 10

Output terminal setting

This command assigns a terminal function to the output intelligent terminal 11. Use this command when changing the terminal function assigned to the terminal.

Assignment of commands to intelligent terminals

Command	Name of function	Terminal symbol	Initial value
C10	Output terminal setting	11	0

3	2	1	PV24	FW	5	4	CM1	CM1	ALO
H	O	OI	L	FM	CM2	11		AL2	AL1

↑  
Output intelligent terminal

Setting procedure

- Press the or key once for a desired terminal setting command.
- The preset value of the terminal is displayed. Press the or key repeatedly until the desired value appears on the display (in reference with the List of Functions), then press the key.
- Return to the command display status and make sure that a new terminal function has been assigned.

Setting example:

Changing the RUN (Run signal) function to the AR (Frequency Arrival signal) functiony

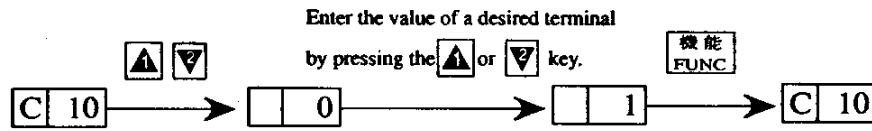

List of Output Terminal Functions

Set value	Symbol	Name of function
0	AR	Frequency Arrival signal
1	RUN	Running signal
2	OL	Overload Precaution signal

Command

Contents and display

C 20

This command changes setting of contacts "a" and "b" for input intelligent terminals 1 to 5.

Input terminal a and b contact setting

Setting procedure

- Press the ▲ or ▼ key once while this command is displayed.
- The currently-set value is displayed. Press the ▲ or ▼ key repeatedly until a desired set value appears (in reference with the List of Contact Functions), then press the 機能 FUNC key.
- Return to the command display status and make sure that a new terminal function has been set.

Setting example:

Using input terminals 1, 3, and 5 as contact "a" and input terminals 2 and 4 as contact "b" (Set value A)

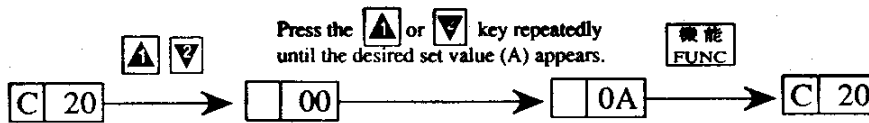

Initial set value 00

Initial set value

List of Contact Functions (for input terminals)

Set value	0F	0E	0d	0C	0b	0A	09	08	07	06	05	04	04	02	01	00
Input terminal 1	b	a	b	a	b	a	b	a	b	a	b	a	b	a	b	a
Input terminal 2	b	b	a	a	b	b	a	a	b	b	a	a	b	b	a	a
Input terminal 3	b	b	b	b	a	a	a	a	b	b	b	b	a	a	a	a
Input terminal 4	b	b	b	b	b	b	b	b	a	a	a	a	a	a	a	a
Input terminal 5	a	a	a	a	a	a	a	a	a	a	a	a	a	a	a	a

a: Contact "a" specification (ON when short-connected)  
 b: Contact "b" specification (ON when opened)

Set value	1F	1E	1d	1C	1b	1A	19	18	17	16	15	14	14	12	11	10
Input terminal 1	b	a	b	a	b	a	b	a	b	a	b	a	b	a	b	a
Input terminal 2	b	b	a	a	b	b	a	a	b	b	a	a	b	b	a	a
Input terminal 3	b	b	b	b	a	a	a	a	b	b	b	b	a	a	a	a
Input terminal 4	b	b	b	b	b	b	b	b	a	a	a	a	a	a	a	a
Input terminal 5	b	b	b	b	b	b	b	b	b	b	b	b	b	b	b	b

Note:

1. An input terminal to which the RS function is assigned can be contact "a" only. Even when contact "b" is assigned to the terminal, contact "a" is automatically set to the terminal.

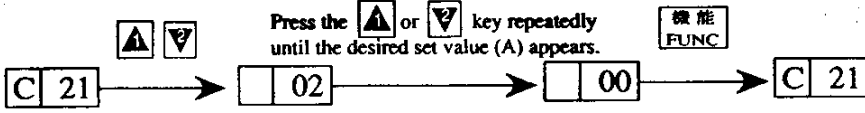
Command	Contents and display																				
<p data-bbox="151 235 255 291">C 21</p> <p data-bbox="135 324 239 526">Output terminal a and b contact setting</p>	<p data-bbox="287 235 1332 302">This command changes setting of contacts "a" and "b" for the output intelligent terminal and the alarm output terminal.</p> <p data-bbox="287 336 478 369">Setting procedure</p> <ul data-bbox="319 380 1340 604" style="list-style-type: none"> <li>- Press the ▲ or ▼ key once while this command is displayed.</li> <li>- The currently-set value is displayed. Press the ▲ or ▼ key repeatedly until a desired set value appears (in reference with the List of Contact Functions), then press the 機能 FUNC key.</li> <li>- Return to the command display status and make sure that a new terminal function has been set.</li> </ul> <div data-bbox="311 627 1316 907" style="border: 1px solid black; padding: 5px;"> <p data-bbox="319 638 502 660">Setting example:</p> <p data-bbox="319 660 1236 694">Using both the output terminal 11 and the alarm terminal as contact "b" (Set value 0)</p>  </div> <div data-bbox="295 940 1284 1254"> <p data-bbox="295 985 478 1019">Initial set value</p> <p data-bbox="327 1030 430 1075">03</p> <p data-bbox="311 1153 598 1220">The leading "0" is always required.</p> <p data-bbox="662 940 1021 1008">List of Contact Functions (for output and alarm terminals)</p> <table border="1" data-bbox="662 1008 1141 1164"> <thead> <tr> <th>set value</th> <th>3</th> <th>2</th> <th>1</th> <th>0</th> </tr> </thead> <tbody> <tr> <td>Output terminal</td> <td></td> <td></td> <td></td> <td></td> </tr> <tr> <td>11</td> <td>b</td> <td>a</td> <td>b</td> <td>a</td> </tr> <tr> <td>Alarm</td> <td>b</td> <td>b</td> <td>a</td> <td>a</td> </tr> </tbody> </table> <p data-bbox="662 1176 1284 1243">a: Contact "a" specification (ON when short-connected) b: Contact "b" specification (ON when opened)</p> </div>	set value	3	2	1	0	Output terminal					11	b	a	b	a	Alarm	b	b	a	a
set value	3	2	1	0																	
Output terminal																					
11	b	a	b	a																	
Alarm	b	b	a	a																	

## 9. PROTECTIVE FUNCTIONS

The J100 series inverters are equipped with protective functions against overcurrent, overvoltage, and undervoltage which protect the inverter. If the protective functions are engaged, the output is shut down, motor runs free and holds that condition until it is reset.

Description	Contents	Display	
Power module protection (NOTE 1)	When output of an inverter is short circuited or the motor is locked, a large current flows through the inverter and causes a fault. When the current flowing through the power module or a temperature abnormality of the main devices comes to certain level, the output is cut off.	Constant speed	E 1
		Dec.	E 2
		Acc.	E 3
		Stop	E 4
Overload protection (NOTE 1)	When a motor overload is detected by the electronic thermal function, the output of the inverter is cut off.	E 5	
Braking resistor overload	When regenerative braking resistor exceeds the usage time ratio an overvoltage caused by the stop of the BRD function is detected, and output of the inverter is cut off.	E 6	
Overvoltage protection	When the converter voltage exceeds a certain level due to regenerative energy from the motor, this protection function engages, and the output of inverter is cut off.	E 7	
EEPROM error (NOTE 2)	When the memory built in has problems due to noise or excessive temperature rise, this protective function engages, and the output of inverter is cut off.	E 8	
Undervoltage protection	A decrease of the input voltage of an inverter results in improper function of the control circuit. It also generates motor heat and causes low torque. Output is cut off when the input voltage goes down to less than 150 V to 160 V (200 V class), 300 V to 320 V (400 V class).	E 9	
CT error	When a large noise source is near the inverter or an abnormality occurs on built-in CT, the output of the inverter is cut off.	E 10	
CPU error	Malfunction or abnormality on built-in CPU and the output of the inverter is cut off.	E 11	
External trip	An abnormality signal from external equipment cuts off the output of the inverter.	E 12	
USP error	It indicates an error when power is turned on while the inverter is being run. (When USP function is selected)	E 13	
Ground fault protection	The inverter is protected by detection of ground faults between the inverter output and the motor upon power on. There may be the possibility of power module failure. This protection is provided for the inverter, not for humans.	E 14	

**NOTE 1:** If a trip occurs, press the reset key after an elapse of 10 seconds to restore the inverter.

**NOTE 2:** If an EEPROM error occurs, be sure to confirm the setting value again.

## Other display





Contents	Display
<p>It is displayed when the registered data in F3 is different from the respective data.                      (For example, it is displayed when confirming V/F data in F5 after <span style="border: 1px solid black; padding: 2px;">06</span> was selected in F3)</p>	<div style="border: 1px solid black; padding: 2px; display: inline-block;"> <span style="border-right: 1px solid black; padding-right: 5px;"> </span> <span style="border-right: 1px solid black; padding-right: 5px;"> </span> <span style="border-right: 1px solid black; padding-right: 5px;"> </span> <span style="border-right: 1px solid black; padding-right: 5px;"> </span> </div>
<p>It is displayed when the fault happens between digital operator and the inverter, or short circuit RS-PV24 for four seconds or more. Pushing down any one of the <span style="border: 1px solid black; padding: 2px;">▲</span> <span style="border: 1px solid black; padding: 2px;">▼</span> and <span style="border: 1px solid black; padding: 2px;">機能 FUNC</span> keys recovers. If not, turn off and on power again.</p>	<div style="border: 1px solid black; padding: 2px; display: inline-block;"> <span style="border-right: 1px solid black; padding-right: 5px;"> </span> <span style="border-right: 1px solid black; padding-right: 5px;"> </span> <span style="border-right: 1px solid black; padding-right: 5px;"> </span> <span style="border-right: 1px solid black; padding-right: 5px;"> </span> </div>
<p>It is displayed when power is shut off.</p>	<div style="border: 1px solid black; padding: 2px; display: inline-block;"> <span style="border-right: 1px solid black; padding-right: 5px;"> </span> <span style="border-right: 1px solid black; padding-right: 5px;"> </span> <span style="border-right: 1px solid black; padding-right: 5px;"> </span> <span style="border-right: 1px solid black; padding-right: 5px;"> </span> </div>
<p>It displays the rest time of retry waiting time after the power recovery of undervoltage when selecting the retry mode.                      (example) <span style="border: 1px solid black; padding: 2px;">-10</span> shows restart after 10 seconds.</p>	<div style="border: 1px solid black; padding: 2px; display: inline-block;"> <span style="border-right: 1px solid black; padding-right: 5px;"> </span> <span style="border-right: 1px solid black; padding-right: 5px;"> </span> <span style="border-right: 1px solid black; padding-right: 5px;"> </span> <span style="border-right: 1px solid black; padding-right: 5px;"> </span> </div>

For display contents when the remote operator or copy unit is used, see page 13-1 and the subsequent pages.

## 10. TROUBLESHOOTING

Symptom	Probable cause	Countermeasure													
The motor will not run.	The inverter outputs U, V and W are not supplying voltage.	<ul style="list-style-type: none"> <li>• Is power being supplied to terminals L1, L2(N), and L3? If it is, the POWER lamp should be on.</li> <li>• Is the display E□□ ?</li> <li>• Is the operation instruction RUN ON? • Is terminal FW (or RV) connected to terminal PV24? .</li> <li>• Has the frequency setter been turned on by pushing  key to select  and then  key.</li> <li>• Are the printed-circuit board terminals H, O and L connected to the potentiometer? .</li> <li>• Has RS/FRS been left ON?</li> <li>• Is the mode key  setting correct? .</li> </ul>	<ul style="list-style-type: none"> <li>• Check terminals L1, L2(N), and L3, U, V, and W.</li> <li>• Turn on the power supply.</li> <li>• Press  and check the content. Then press the reset key.</li> <li>• Set to ON.</li> <li>• Connect terminal PV24 to terminal FW (or RV) on the printed-circuit board. (When the terminal mode is selected.)</li> <li>• Push down keys and set.</li> <li>• When terminal mode is selected, connect the potentiometer to H, O, and L, and then set.</li> <li>• Release reset.</li> <li>• Read the instruction manual again (8-10).</li> </ul>												
	Inverter outputs U, V, and W are supplying voltage.	<ul style="list-style-type: none"> <li>• Has the motor seized or is the load too great?</li> </ul>	<ul style="list-style-type: none"> <li>• Release seizure or lighten the load.</li> <li>• Test the motor independently.</li> </ul>												
	The optional remote operator is used. (copy unit)	<ul style="list-style-type: none"> <li>• Are the operational settings between the remote operator and inverter unit correct? .</li> </ul>	<ul style="list-style-type: none"> <li>• Check the operation of the optional remote operator. (copy unit)</li> </ul> <div style="margin-top: 10px;"> <table style="border: none;"> <tr> <td style="padding-right: 10px;">ON</td> <td style="border: 1px solid black; padding: 2px;">1</td> <td style="border: 1px solid black; padding: 2px;">2</td> <td style="border: 1px solid black; padding: 2px;">3</td> <td style="border: 1px solid black; padding: 2px;">4</td> <td style="padding-left: 10px;">1: OFF</td> </tr> <tr> <td>OFF</td> <td style="border: 1px solid black; padding: 2px;"><input type="checkbox"/></td> <td style="border: 1px solid black; padding: 2px;"><input type="checkbox"/></td> <td style="border: 1px solid black; padding: 2px;"><input type="checkbox"/></td> <td style="border: 1px solid black; padding: 2px;"><input type="checkbox"/></td> <td>2: ON (Same as J300)</td> </tr> </table> </div>	ON	1	2	3	4	1: OFF	OFF	<input type="checkbox"/>	<input type="checkbox"/>	<input type="checkbox"/>	<input type="checkbox"/>	2: ON (Same as J300)
	ON	1	2	3	4	1: OFF									
	OFF	<input type="checkbox"/>	<input type="checkbox"/>	<input type="checkbox"/>	<input type="checkbox"/>	2: ON (Same as J300)									
	The direction of the motor is reversed.	<ul style="list-style-type: none"> <li>• Are the connections of output terminals U, V, and W correct?</li> <li>• Is the phase sequence of the motor forward or reverse in respect to U, V, and W?</li> </ul>	<ul style="list-style-type: none"> <li>• Make the connections according to the phase sequence of the motor. (In general, forward should be in the sequence: U, V, and W.)</li> </ul>												
<ul style="list-style-type: none"> <li>• Are the terminals on the printed-circuit board correct? .</li> <li>• Is the mode key  set correctly ?</li> </ul>		<ul style="list-style-type: none"> <li>• Terminal FW for forward, and RV for reverse.</li> </ul>													



Symptom		Probable cause	Countermeasure
The rpm of the motor will not increase.		<ul style="list-style-type: none"> <li>• After checking the wiring of the frequency setter, the rpm still does not increase when the setter is turned.</li> </ul>	<ul style="list-style-type: none"> <li>• Replace the frequency setter.</li> </ul>
		<ul style="list-style-type: none"> <li>• Are terminals 1 and PV24, terminal 2 and PV24, terminal 3 and PV24 ON?</li> </ul>	<ul style="list-style-type: none"> <li>• Turn off terminal 1, 2, and 3. (When the frequency and multistage speed are fixed at a given frequency, the speed potentiometer will be invalid.)</li> </ul>
		<ul style="list-style-type: none"> <li>• Is the load too great?</li> </ul>	<ul style="list-style-type: none"> <li>• Decrease the load.</li> <li>• When the load is too great, the limiting function will be activated, so that the rotational speed will be lower than the setting.</li> </ul>
Rotation is unstable.		<ul style="list-style-type: none"> <li>• Is the fluctuation in load too great?</li> <li>• Is the power supply voltage fluctuating?</li> <li>• Is some peculiar frequency causing the problem?</li> </ul>	<ul style="list-style-type: none"> <li>• Increase the capacity. (Both of the motor and inverter.)</li> <li>• Decrease the fluctuation.</li> <li>• Change the output frequency slightly.</li> </ul>
The rpm of the motor does not match the inverter.		<ul style="list-style-type: none"> <li>• Is the maximum frequency setting correct?</li> <li>• Are the number of motor poles, the gear ratio, and pulley ratio correct?</li> </ul>	<ul style="list-style-type: none"> <li>• Check the V/F pattern against the motor specifications.</li> <li>• Check the speed-change ratio.</li> </ul>
The data is incorrect.	The data has not changed.	<ul style="list-style-type: none"> <li>• Was the power turned off without pushing the  key after the data was changed with   keys.</li> </ul>	<ul style="list-style-type: none"> <li>• Input the data and push the  key once.</li> </ul>
		<ul style="list-style-type: none"> <li>• The data is memorized upon power off. Is the time from power OFF to ON less than six seconds?</li> </ul>	<ul style="list-style-type: none"> <li>• Take six seconds or more when turning power OFF and ON after changing the data.</li> </ul>
	Data copied by the copy unit is not input.	<ul style="list-style-type: none"> <li>• Is the power turned off for six seconds or more after the display changed from REMT to INV.</li> </ul>	<ul style="list-style-type: none"> <li>• Copy again and turn the power off six seconds or more after copying.</li> </ul>

Symptom		Probable cause	Countermeasure
The data is not changed.	Frequency setting can not be changed. Run and stop can not be done.	<ul style="list-style-type: none"> <li>• The change of the terminal mode and digital operator mode were correct?</li> </ul>	<ul style="list-style-type: none"> <li>• Confirm the change in <b>F 9</b> setting mode. (See page 8-12.)</li> </ul>
	The data can not be changed.	<ul style="list-style-type: none"> <li>• Is software lock ON?</li> <li>• Is software lock ON with software lock selection <b>A04</b> (date: 1)</li> <li>• Is the switch 4 mounted on the back of the remote operator (copy unit) ON? (See page 13-2)</li> </ul> <p>Note: If software lock is ON because of use with an explosion proof motor, do not release the software locks.</p>	<ul style="list-style-type: none"> <li>• Open SFT terminal and PV24.</li> <li>• Change the data of <b>A04</b> to 1 to 0.</li> <li>• Turn the switch OFF.</li> </ul>

### Precautions for data setting

When changing any set data by one of the following methods (① to ③), keep the equipment unoperated for 6 seconds or more after the selected method is executed. When any key is pressed, or the reset operation is performed, or the power is turned off within 6 seconds, correct data may not be set.

- ① Changing the data and pressing the **記憶 STR** key to store the data
- ② Operating the **コピー COPY** key when copying another inverter data using the copy unit (DRW) (See page 13-12.)
- ③ Returning to the initialization (the factory settings) (See page 7-7.)

## 11. MAINTENANCE AND INSPECTION

### 11.1 Maintenance and Inspection Precautions

#### WARNING

- After a lapse of more than 5 minutes after turning off the input power supply, perform the maintenance and inspection.  
Otherwise, there is a danger of electric shock.
- Make sure that only qualified persons will perform maintenance, inspection and part replacement. (Before starting the work, remove metallic objects from your person (wristwatch, bracelet, etc.)  
(Be sure to use tools protected with insulation.)  
Otherwise, there is a danger of electric shock and/or injury.

#### CAUTION

- When removing connectors, never pull the wires. (Wires for cooling fan and thermal relay)  
Otherwise, there is a danger of fire due to wire breakage and/or injury.

- General precautions

Always keep the unit clean so that dust or other foreign matter does not enter the inverter. Take special care in regard to breaking lines and connection mistakes. Firmly connect terminals and connectors. Keep electronic equipment away from moisture and oil. Dust, steel filings and other foreign matter can damage insulation, causing unexpected accidents, so take special care.

### 11.2 Inspection Items

- (1) Daily inspection
- (2) Periodic inspection (Approximately once a year)
- (3) Insulation resistance tests, withstand voltage tests

Conduct these tests by short-circuiting the terminals as shown below, and by following the conditions described.

- In regard to insulation resistance tests, measure the terminals below and the grounding at 500 VDC, and make sure that 5 M-ohms or greater is indicated.
- Do not perform the withstand voltage test. When it should be done, in regard to withstand voltage tests, supply the terminals below and the grounding with 1500 VAC (200 V class), 2000 VAC (400 V class) for one minute, and make sure that there are no abnormalities.
- Do not conduct insulation resistance tests and withstand voltage tests for terminals other than those indicated below.  
Increase or decrease the applied voltage for the withstand voltage test slowly and turn the equipment 0 V again.

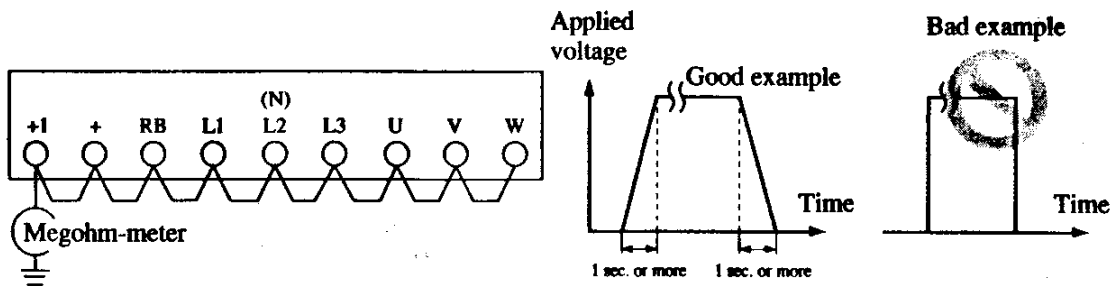

**Insulation Resistance Tests and Withstand Voltage Tests**

- Remove short-cut wire on the power PCB before conducting the test. And be sure to attach short-cut wire after the test.( for 400V class only)

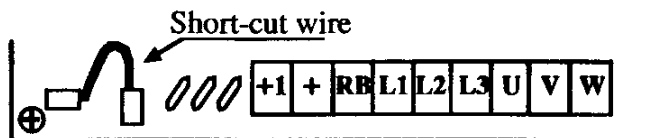

**NOTE 1:** If the inverter is used under high temperature and heavy load conditions, its operating life will be significantly reduced.

**NOTE 2:** If the inverter has been stored for three years or more, apply the following conditions.

Apply 80% of the rated voltage of the capacitor for 1 hour at normal temperature.

A Increase the voltage to 90% and apply it for 1 hour.

B Apply the rated voltage for 5 hours.

**NOTE 3:** Precautions in handling printed-circuit boards.

When maintenance and inspection of printed-circuit boards is necessary, be sure to follow the precautions below.

- Prevent damage caused by static electricity. The MCUs and ICs on a printed-circuit board can be destroyed by static electricity, so be sure to ground work benches, soldering irons, and yourself before working on a printed-circuit board.

We recommend that the following parts be stocked to reduce down time.

**Recommended Spare Parts**

Part description	Symbol	Quantity		Remarks
		Used	Spare	
Main circuit P.C. board assembly	POWER PCB	1	1	Main circuit device, circuit parts, fin assembly
Cooling fan	FAN	1	1	Used for 015SFE5 and 022SFE5 015HFE5 to 037HFE5
Smoothing capacitor P.C. board assembly	CB PCB	1	1	Used for 015SFE5 to 022SFE5 015HFE5 to 037HFE5 Store this part at a temperature ranging from -20°C to 30°C
Digital operator	D. OPE	1	1	Applicable for all models
Logic P.C. board	LOGIC PCB	1	1	Same as above (Input kw data)

### Daily Inspection and Periodic Inspection (1/3)

Inspection location	Inspection item	Inspection content	Inspection cycle		Inspection method	Criteria	Standard replacement period	Instruments
			Daily	Periodic				
Overall	Ambient environment	Check ambient temperature, humidity, dust, corrosive gases, oil mist, etc.	✓			Ambient temperature between -10 to +40°C; no icing. Ambient humidity 20 to 90%; no dew condensation.	—	Thermometer
	Devices overall	Check for abnormal vibrations and noise.	✓		Visual and aural inspection.			Hygrometer
	Power supply voltage	Check the input line voltage.	✓		Measure the voltage between inverter terminals R, S, and T.	No abnormalities. 220 to 240 V, 50/60 Hz 380 to 415 V, 50 Hz 400 to 460 V, 60 Hz		Tester
Main circuit	Overall	(1) Insulation resistance test (between main circuit terminals and grounding terminal)	✓			No abnormalities in (1) and (2).	—	500 V class Megohm meter
		(2) Check installation for looseness.		✓	(1) Tighten.	Tightening torque (except for terminal block): • M3 (Diode module): 0.59 - 0.79 N•m • M4 (Power module): 0.98 - 1.47 N•m		
		(3) Check for evidence of overheating in the various components.		✓	(2) Visual inspection.	• M3: 0.79 - 0.98 N•m • M4: 0.98 - 1.18 N•m.		
		(4) Clean.		✓				

**Daily Inspection and Periodic Inspection (23)**

Inspection location	Inspection item	Inspection content	Inspection cycle		Inspection method	Criteria	Standard replacement period	Instruments
			Daily	Periodic				
Main circuit	Terminal block	No damage.		✓	Visual inspection	No abnormalities.		
	Smoothing capacitor	(1) Check for leaking	✓		Visual inspection of (1) and (2).	No abnormalities in (1) and (2).	5 years (NOTE)	Capacity meter
		(2) Check for swelling	✓					
	Relays	(1) Check for stuttering noise when operating		✓	(1) Aural inspection.	(1) No abnormalities.	—	
	Resistors	(1) Check for large cracks or changes in color		✓	(1) Visual inspection	(1) No abnormalities.		Tester
	Cooling fan	(1) Check for abnormal vibrations and noise	(2) Check for dust	✓		(1) Rotate manually with power off. (2) Increase tightening	(1) Smooth rotation (2) No abnormality	2 - 3 years
				✓				

### Daily Inspection and Periodic Inspection (3/3)

Inspection location	Inspection item	Inspection content	Inspection cycle		Inspection method	Criteria	Standard replacement period	Instruments
			Daily	Periodic				
Control circuit	Operation check	(1) Check the balance of the output voltage of individual phases when operating the inverter independently.  (2) Conduct a sequence protection operation test, and make sure that there are no errors in the protection and display circuits.		✓	(1) Measure the voltage between the phases of inverter output terminals U, V, and W.  (2) Simulate operation of the inverter protection circuit.	(1) Within 2% voltage difference between phases.  (2) Operate without any abnormalities.	—	—
	Component check, including printed-circuit boards	(1) No abnormal odor or changes in color.  (2) No significant corrosion.		✓	Visual inspection	No abnormalities	—	—
Display	Capacitor	No fluid leakage or deformation.	✓		Visual inspection		5 years (NOTE)	—
	Digital operation panel	(1) No illegible display (2) No lack of character (3) No blown out LEDs	✓		Visual inspection	Normal operation Display can be read out.	7 years	—
			✓					

**NOTE:** 1. The life of capacitor will be affected by the ambient temperature. See Appendix 3 Capacitor Life Curve.  
 2. The inverter must be cleaned periodically. If dust accumulates on the fan and heat sink, it can cause overheating of the inverter.







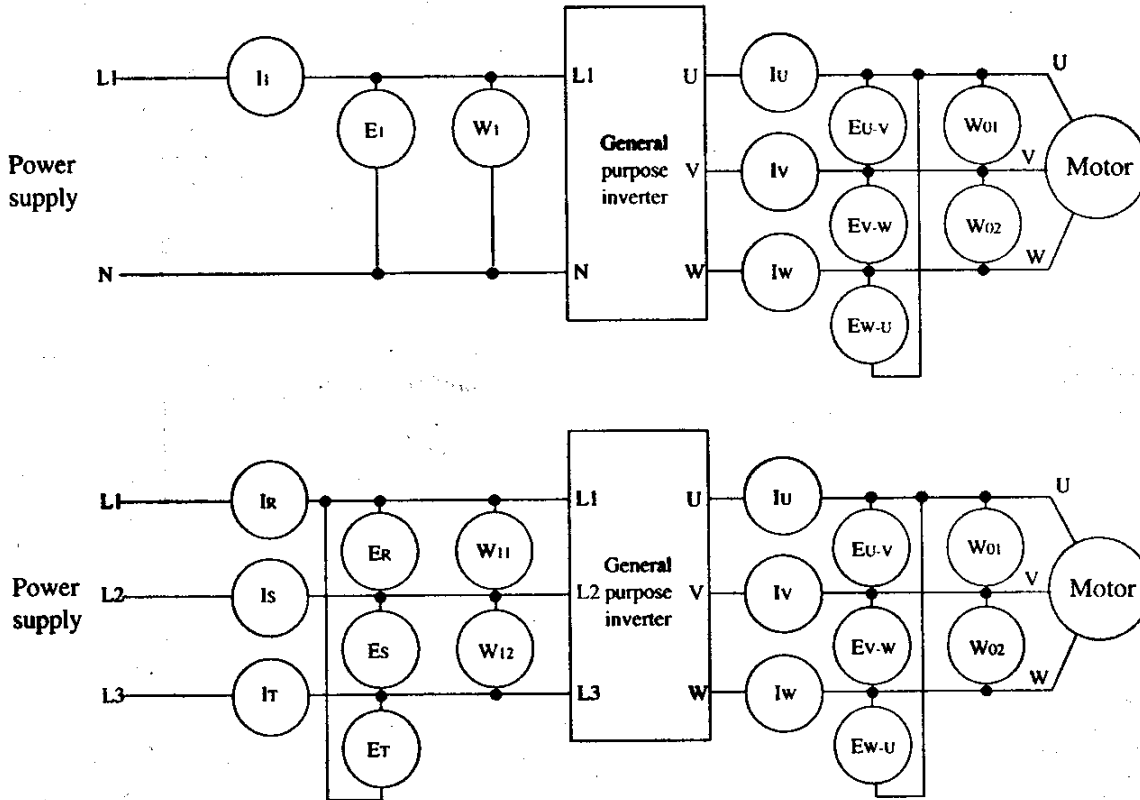

### 11.3 Measurement Method for I/O Voltage, Current, and Power

General measuring instruments for I/O voltage, current, and power are indicated below. The voltage to be measured is the fundamental wave effective voltage and the power to be measured is the total effective value.



**Table 3 Parts to be measured**

Measurement item	Parts to be measured	Measuring instrument	Remarks	Reference value
Supply voltage $E_1$	Between L1 and L2, L2 and L3, L3 and L1 (ER) (ES) (ET)	 Moving-iron type voltmeter or rectifier type voltmeter	Fundamental wave effective value	Commercial supply voltage 1 $\phi$ 200 V class 220-240 V, 50/60 Hz 3 $\phi$ 400 V class 380-415 V 50 Hz 400-460 V 60 Hz
Supply current $I_1$	L1, L2, L3 (IR)(IS)(IT)	 Moving-iron type ammeter	Total effective value	
Supply power $W_1$	Between L1 and L2, L2 and L3 (W11)(W12)	 Electrodynamic type wattmeter	Total effective value	
Supply power factor $Pf_1$	Calculate the supply power factor from the measured supply voltage, $E_1$ , supply current $I_1$ and supply power $W_1$ . $Pf_1 = \frac{W_1}{\sqrt{3} \cdot E_1 \cdot I_1} \times 100(\%)$			
Output voltage $E_0$	Between U and V, V and W, W and U (Eu)(Ev)(Ew)	 Rectifier type voltmeter	Total effective value	
Output current $I_0$	U, V, W (Iu)(Iv)(Iw)	 Moving-iron type ammeter	Total effective value	
Output power $W_0$	Between U and V, V and W (W01)(W02)	 Electronic type wattmeter	Total effective value	
Output power factor $Pf_0$	Calculate the output power factor from the output voltage E, output current I, and output power W. $Pf_0 = \frac{W_0}{\sqrt{3} \cdot E_0 \cdot I_0} \times 100(\%)$			

**NOTE 1:** Use a meter indicating a fundamental wave effective value for voltage, and meters indicating total effective values for current and power.

**NOTE 2:** The inverter output waveform is a distorted wave, and low frequencies may cause errors. However, the measuring instruments and methods indicated above provide comparatively accurate values.

**NOTE 3:** A tester (general purpose) may not be suited often to measurement of a distorted wave.

## 12. STANDARD SPECIFICATIONS

Model designation		J100-004SFES	J100-007SFES	J100-015SFES	J100-022SFES	J100-015HFES	J100-022HFES	J100-037HFES
Protective structure (NOTE 1)		IP20						
Over voltage category		III						
Maximum motor size (4P, kW)(NOTE 2)		0.4	0.75	1.5	2.2	1.5	2.2	3.7
Maximum capacity (kVA)	220 V	1.1	1.9	2.9	4.0			
	240 V	1.2	2.1	3.1	4.4			
	400 V					2.6	3.7	6.0
	460 V					2.9	4.0	6.5
Input supply phase		Single-phase				Three-phase, 3 wire, earthed neutral		
Rated input AC voltage (V)		220 to 230 V $\pm 10\%$ , 50/60 Hz $\pm 5\%$ 240 V $+5\%$ , $-10\%$ , 50/60 Hz $\pm 5\%$				380 to 415/400 to 460 V $\pm 10\%$ , 50/60 Hz $\pm 5\%$		
Rated output voltage (V) (NOTE 3)		Three-phase 220 to 240 (Corresponds to input voltage.)				Three-phase 400 to 460 (Corresponds to input voltage.)		
Rated input current (A)		6	10	15	21	5	7	11
Rated output current (A)		3	5	7.5	10.5	3.8	5.3	8.6
Output frequency range (NOTE 4)		0.5 to 360 Hz						
Frequency accuracy		$\pm 0.01\%$ of the maximum frequency Analog $\pm 0.2\%$ (25 $\pm 10^\circ\text{C}$ )						
Frequency setting resolution		0.01 Hz						
Voltage/frequency characteristics		V/F any type possible. High starting torque, standard starting torque (constant torque, reduced torque)						
Overload current capacity		150%, 60 seconds						
Acceleration/deceleration time		0.1 to 999 seconds, individually set (independent settings from 0.1 to 2999.9 seconds are possible when the remote operator is used.)						
Starting torque (NOTE 5)		150% or more (3 Hz)						
Braking torque	Dynamic braking (NOTE 6) Feedback to capacitor	Approx. 20%						
	Dynamic braking using external regenerative resistor	150%			100%			
	DC injection braking	Braking is ON at the min. frequency or less. Braking can be selected by the remote operator. (Min. frequency, operative frequency, brake time and brake force can be set.)						

Model designation			J100-004SFE5	J100-007SFE5	J100-015SFE5	J100-022SFE5	J100-015HFE5	J100-022HFE5	J100-037HFE5
Input signals	Frequency setting	Digital operator	Settings with ▲ ▼						
		External signals	0 - 5 VDC (nominal), 0 - 10 VDC (nominal) (Input impedance 30 k $\Omega$ ) 4 - 20 mA (nominal) (Input impedance 250 $\Omega$ ) Potentiometer: 500 $\Omega$ to 2 k $\Omega$ (2 W) Variable resistor						
	Forward/reverse run, stop	Digital operator	[RUN]/[STOP] switch (The forward run (FW) when shipped from the factory)						
		FW command	FW/STOP						
	Intelligent input terminal	REV: Reverse run command CF1: Change of multi-stage first speed CF2: Change of multi-stage second speed CF3: Change of multi-stage third speed DB: External DB input STN: Initial setting SET: Change of second setting function 2CH: Change of 2 accel/decel speed FRS: Free run input EXT: External trip terminal USP: USP function RS: Reset SFT: Software lock input							
	Intelligent output terminal	AR: Frequency arrival signal RUN: RUN signal OL: Overload previous notice signal							
Output signals	Frequency monitoring	Analog meter (0 - 10 VDC 1 mA full-scale) Selection of the digital frequency signal or analog output current monitor.							
Fault alarm contact			ON when the inverter is abnormal (1c contact)						
Other characteristics			Change of V/F patter, curve accel/decel, upper/lower limiter, output current signal, DC voltage monitoring, output frequency display, trip history monitoring (memorable up to 3 times), etc.						
Protection functions			Overcurrent, overvoltage, undervoltage, electronic thermal, temperature abnormality, ground fault overcurrent upon starting, overload limit						

Model designation		J100-004SFES	J100-007SFES	J100-015SFES	J100-022SFES	J100-015HFES	J100-022HFES	J100-037HFES	
General specifications	Ambient temperature	-10 to 40°C (-10 to 50°C when cover removed.)				-10 to 40°C (with cover)	-10 to 50°C (without cover)		
	Humidity	20 to 90% RH (no dew condensation)							
	Vibrations	5.9 m/S <sup>2</sup> (0.6G) 10 - 55 Hz							
	Operation location	1,000 meter or less altitude, indoors (no corrosive gas or dust)							
	Paint color	Gray							
Options	Remote operator, copy unit, cable for digital operator, regenerative resistor, reactor for improving power factor, noise filter for inverters, L type fitting for connection of electric tube								
Estimated mass (kg)	1.3	1.6	3.3	3.4	3.3	3.4	3.4		

\* With use of a remote operator or a digital operator, the functions can be expanded.  
See Chapter 13.

**NOTE 1:** Protective structure is based upon JEM1030 (1977).

**NOTE 2:** The applicable motor is a Hitachi standard four-pole motor. When using another motor, make sure that the rated motor current does not exceed the rated inverter current.

**NOTE 3:** The output voltage will decrease if input voltage decreases.

**NOTE 4:** Confirm with the motor manufacturer the motors maximum rpm when using a motor running at frequency higher than 50/60 Hz.

**NOTE 5:** When using the Hitachi standard four-pole motor running at frequency higher than 50/60 Hz.

**NOTE 6:** Torque will be reduced when the base frequency exceeds 50/60 Hz.

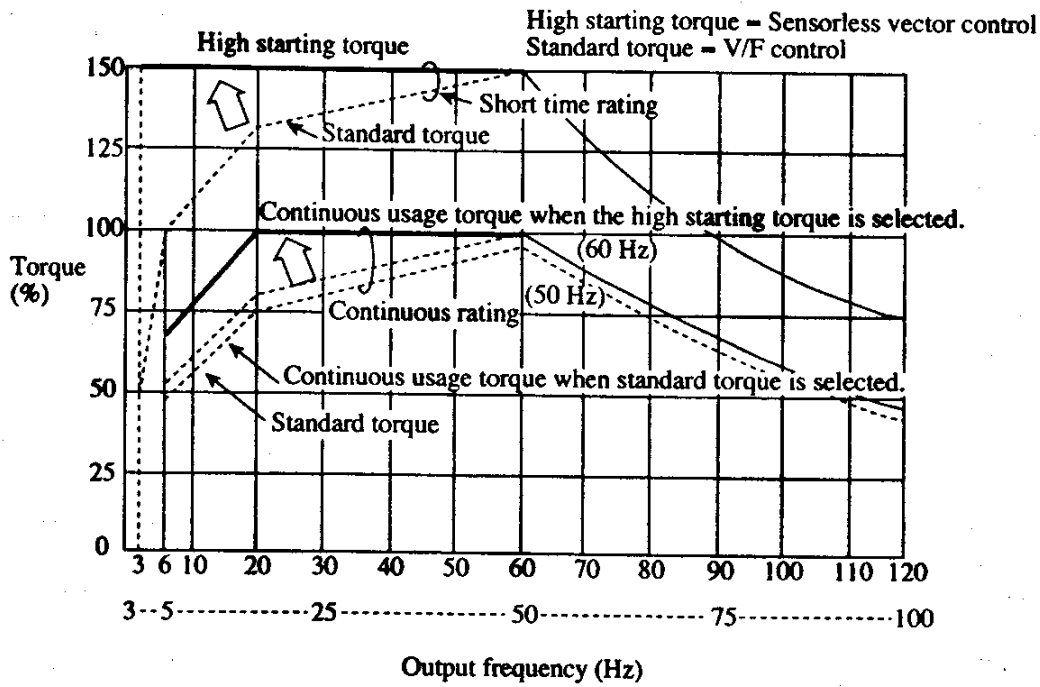

NOTE: Using the Hitachi standard four-pole motor

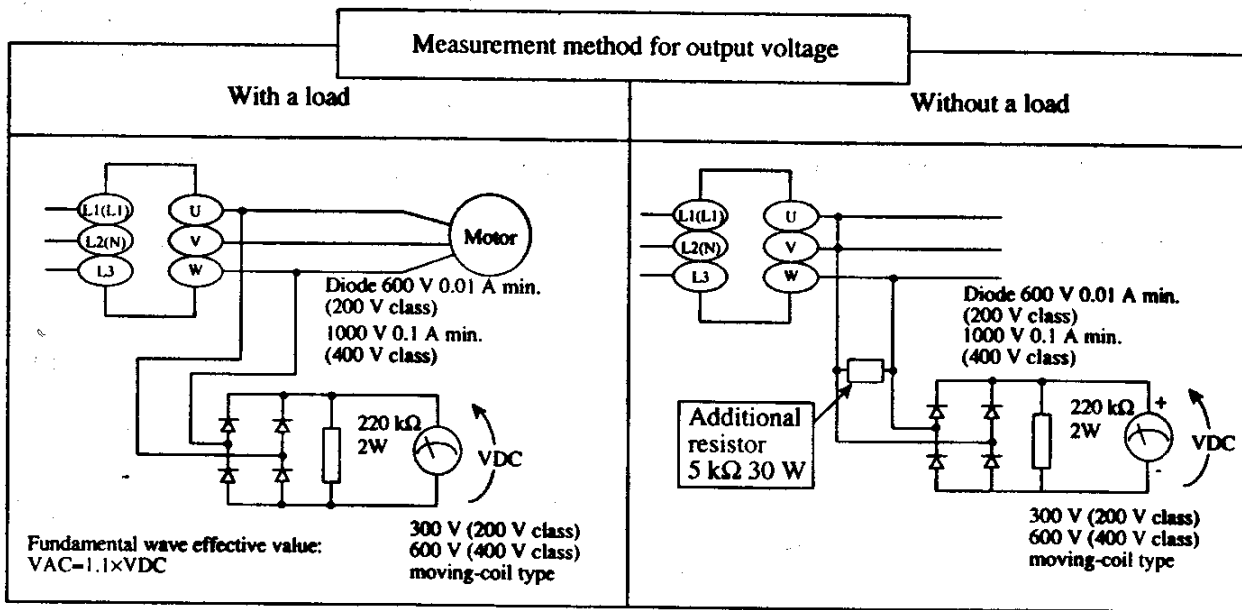

# Terminal Connection Diagram

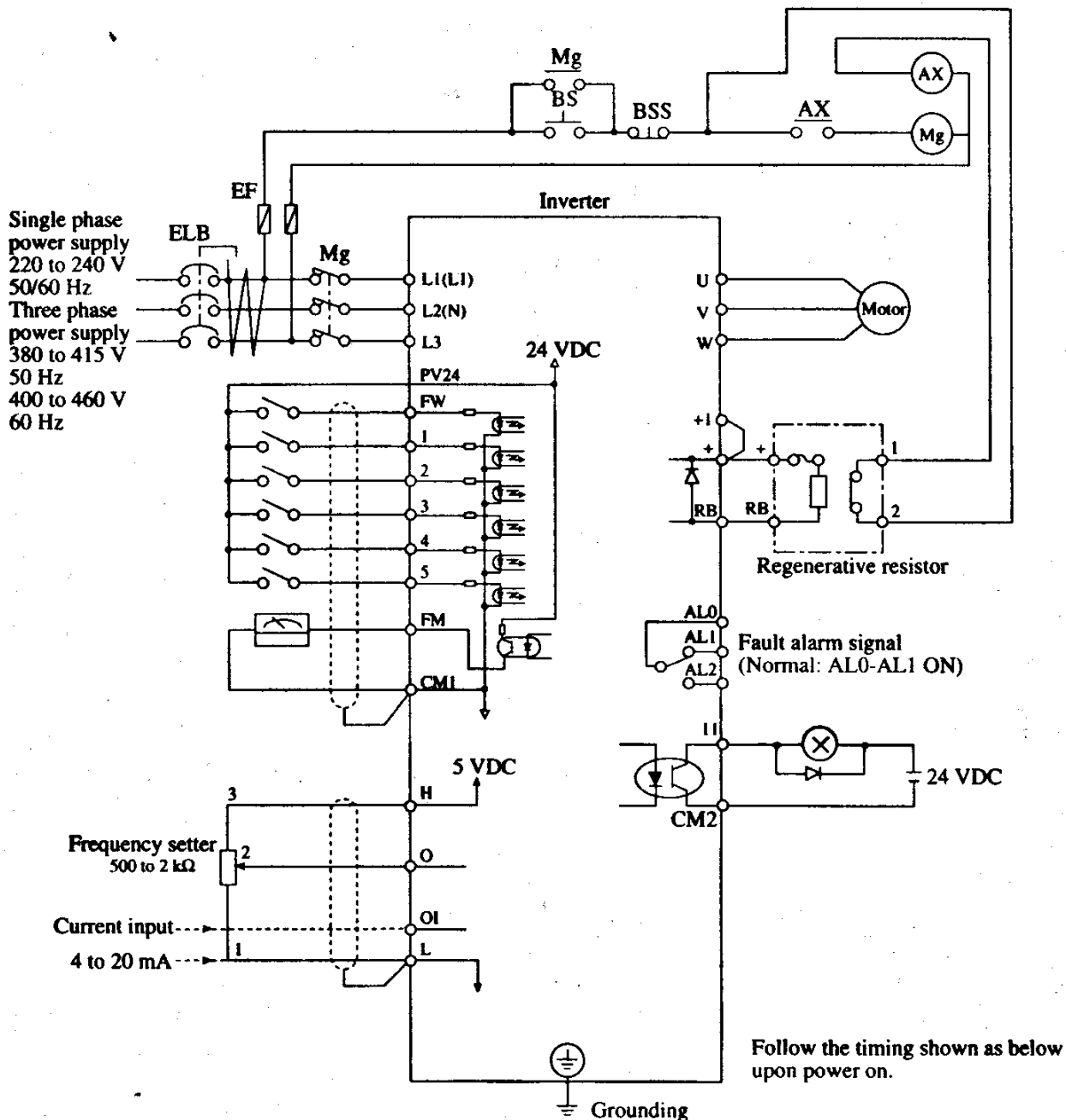

Follow the timing shown as below upon power on.

**NOTE 1:** Common terminal for each terminal is different.

Terminal name	FW, 1, 2, 3, 4, 5	FM	H, O, OI	11
Common	PV24	CMI	L	CM2

**NOTE 2:** The regenerative resistor has a temperature sensor. When it works, turn off power supply to the inverter or set the deceleration time longer.

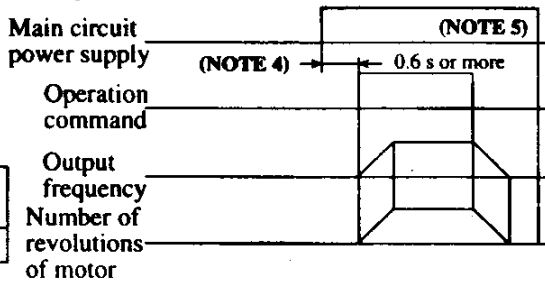

**NOTE 3:** When the operation command is input first and the main circuit power is turned ON, a direct start results and a trip occurs.

**NOTE 4:** Do not input the operation command simultaneously when the main circuit is turned on.

**NOTE 5:** Do not turn OFF the main circuit power during running.

Dimension Diagram

J 100-004SFE5/007SFE5

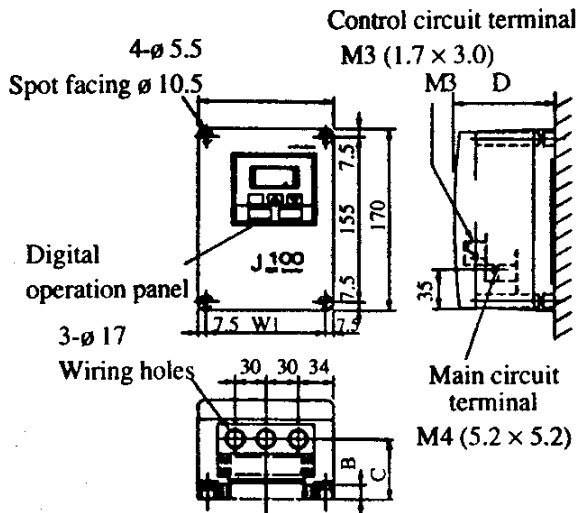

	W	W1	D	C	B
J100-004SFE5	128	113	93	55	14.5
J100-007SFE5	145	130	103	69	18.5



J 100-015SFE5/022SFE5/015HFE5/022HFE5/037HFE5

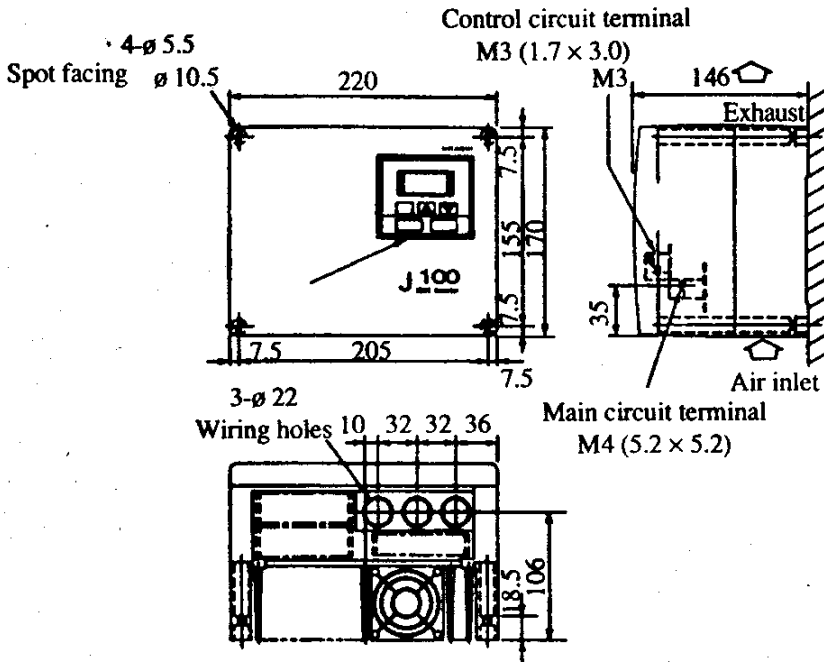

Digital operator

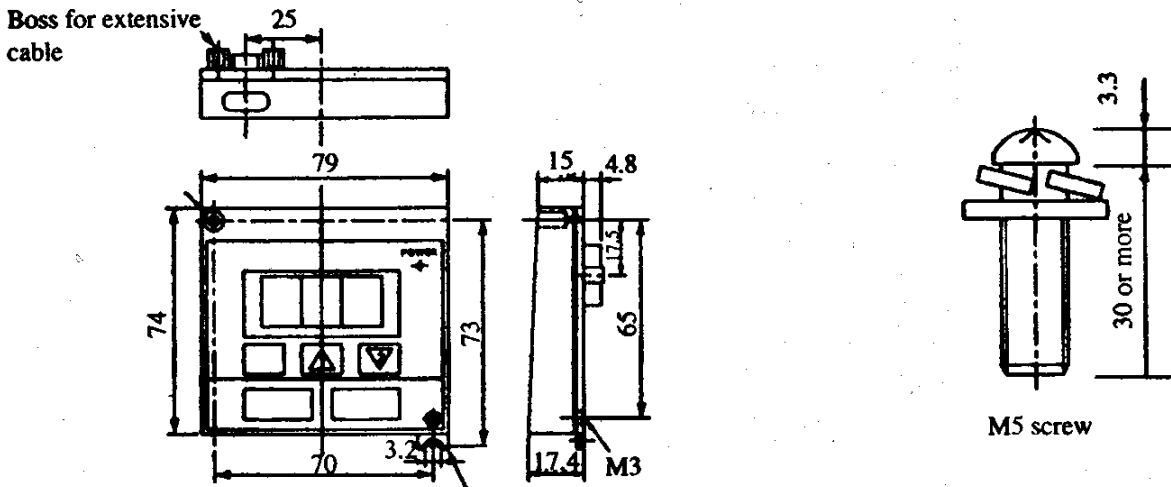

This section can be knocked out and mounted with an M3 screw.

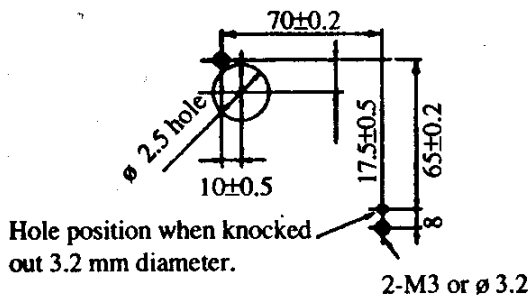

## 13. FUNCTIONS WHEN USING THE OPTIONAL REMOTE OPERATOR

### 13.1 Connecting the remote operator

Be sure to turn the power supply off when connecting the connector.

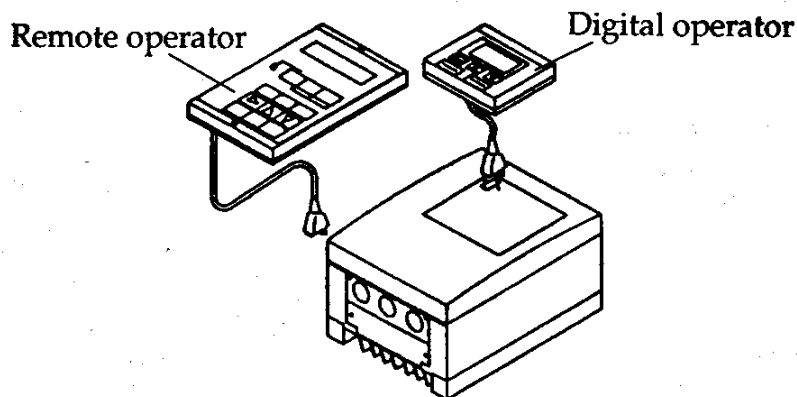

- (1) Insert the connector straight into the remote operator and inverter unit printed-circuit board.
- (2) Turn on the power supply.
- (3) Make sure that the liquid crystal display of the remote operator is lit.

When the power supply of the inverter is turned on, **FS000.0.....** of the monitoring mode will be displayed. If, however, any of the following is displayed when the inverter is turned off, they will be displayed when power is turned on again.

- Frequency setting, multi-speed setting or other frequency displays, motor rotational speed display, frequency conversion display, or output current display.

**NOTE:** See the operation manual of the remote operator for instructions.  
 In addition, see the following pages for details on its various functions. Set the dip-switches mounted on the backside of the remote operator and copy unit as below.

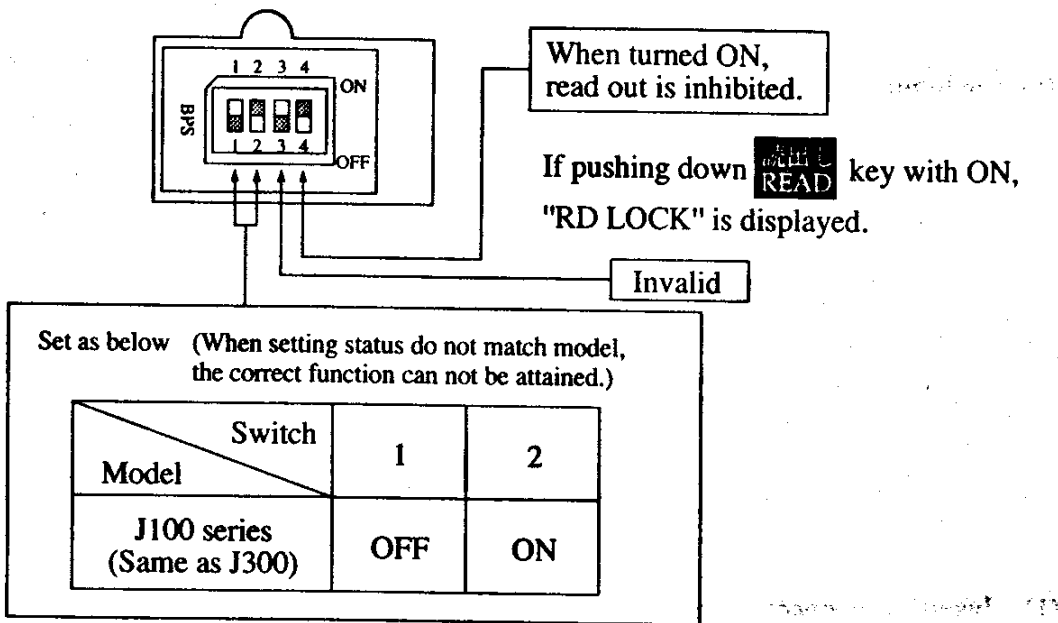

Y : Setting can be changed during operation  
 N : Setting can not be changed during operation  
 - : Display only

Monitoring mode displays  
 (when the remote operator is used)

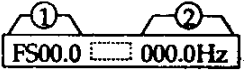
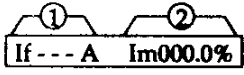
Display sequence	Monitor name	Display content	Standard setting	Setting range	Setting and change are possible?	Remarks
1	Frequency setting and output frequency		000.0	000.0 to 375.0	Y	(1) displays the setting. (2) displays the output. • [ ] is displayed when run instruction is ON.  F: Forward run R: Reverse run  Displayed during multistage operation.
	Multistage-speed setting and output frequency	1S005.0 [ ] 000.0Hz	000.0			
		2S020.0 [ ] 000.0Hz	000.0			
		3S040.0 [ ] 000.0Hz	000.0			
	Expansion multistage speed	4S000.0 [ ] 000.0Hz	000			
		5S000.0 [ ] 000.0Hz				
		6S000.0 [ ] 000.0Hz				
7S000.0 [ ] 000.0Hz						
2	Acceleration time setting	ACCEL-1 0010.0S	10.0 (15.0)	0.1 to 2999.9	Y	
3	Deceleration time setting	DECEL-1 0010.0S	10.0 (15.0)	0.1 to 2999.9	Y	
4	2-stage acceleration time setting	ACCEL-2 0010.0S	10.0	0.1 to 2999.9	Y	
5	2-stage deceleration time setting	DECEL-2 0010.0S	10.0	0.1 to 2999.9	Y	
6	Frequency setting command	F-SET-M Terminal	Terminal	Remote Terminal	N	REMOTE: Setting from the remote operator TERMINAL: Setting from the inverter terminal
7	Operation command method	F/R-SW Terminal	Terminal	Remote Terminal	N	
8	Revolution speed display	RPM 4P 00000RPM	4	2 to 48	Y	Synchronized speed display
9	Output current display		-	1.5 to 23	Y	(1) displays the rated current of the inverter (2) displays output current
10	DC voltage display	PN-V 000V	-	-	-	
11	Manual torque boost adjustment	V-Boost Code<11>	11	00 to 99	Y	
12	Output voltage gain adjustment	V-Gain 100%	100	50 to 100	Y	
13	Analog meter adjustment	M-ADJ 72	72	01 to 99	Y	
14	Failure display	# [ ]	-	-	-	#: Normal operation, Alarm content takes precedence over all other displays.
		? ERROR Over V.				
15	Trip history monitor	? ERR COUNT 000	-	-	-	Displays three alarms of the past (Voltage and current upon alarm)

0.5 N·m (max. 0.7 N·m)

NOTE: When data is changed, be sure to press the  key. (Otherwise, the changed data may not be stored.)

The following functions can be obtained with connection of J-100-series to the remote operator (DOP) or the copy unit (DRW). However, selection is limited within the terminal functions.

**Function mode**

Display sequence	No.	Function name	Display content (Function mode 2)	Standard setting	Setting range	Remarks																																	
1	F-00	V/F pattern setting	CONTROL VF	VF	SLV1, SLV2 or VF	High starting torque (SLV1, SLV2) standard starting torque (VF)																																	
2	F-01	Maximum frequency adjustment	+Fmax. 000.0 Hz	0	0 to 15 (Hz)	Adjustment against the maximum frequency set at F-00																																	
3	F-02	Start frequency adjustment	Fmin. 000.5 Hz	0.5	0.5 to 5.0 (Hz)																																		
4	F-03	Maximum frequency limiter setting	H-LIM-F 000.0 Hz	0	0 to 375 (Hz)	Set the maximum and minimum set frequency.																																	
5	F-04	Minimum frequency limiter setting	L-LIM-F 000.0 Hz	0	0 to 375 (Hz)	Both F03 and F04 are 0. : Not valid																																	
6	F-05	Multistage-speed first speed setting	Speed-1 000.0 Hz	0	0 to 375 (Hz)	Setting the multistage speed <table border="1"> <thead> <tr> <th colspan="3">Control circuit terminal</th> <th rowspan="2">Set frequency</th> </tr> <tr> <th>1</th> <th>2</th> <th>3</th> </tr> </thead> <tbody> <tr> <td>ON</td> <td>OFF</td> <td></td> <td>(1S) F-05</td> </tr> <tr> <td>OFF</td> <td>ON</td> <td>OFF</td> <td>(2S) F-06</td> </tr> <tr> <td>ON</td> <td>ON</td> <td></td> <td>(3S) F-07</td> </tr> <tr> <td>ON</td> <td>OFF</td> <td rowspan="3">ON</td> <td>(4S) F-08</td> </tr> <tr> <td>OFF</td> <td>ON</td> <td>(5S) F-09</td> </tr> <tr> <td>ON</td> <td>ON</td> <td>(6S) F-10</td> </tr> <tr> <td>OFF</td> <td>OFF</td> <td></td> <td>(7S) F-11</td> </tr> </tbody> </table>	Control circuit terminal			Set frequency	1	2	3	ON	OFF		(1S) F-05	OFF	ON	OFF	(2S) F-06	ON	ON		(3S) F-07	ON	OFF	ON	(4S) F-08	OFF	ON	(5S) F-09	ON	ON	(6S) F-10	OFF	OFF		(7S) F-11
Control circuit terminal			Set frequency																																				
1	2	3																																					
ON	OFF		(1S) F-05																																				
OFF	ON	OFF	(2S) F-06																																				
ON	ON		(3S) F-07																																				
ON	OFF	ON	(4S) F-08																																				
OFF	ON		(5S) F-09																																				
ON	ON		(6S) F-10																																				
OFF	OFF		(7S) F-11																																				
7	F-06	Multistage-speed second speed setting	Speed-2 000.0 Hz	0	0 to 375 (Hz)																																		
8	F-07	Multistage-speed third speed setting	Speed-3 000.0 Hz	0	0 to 375 (Hz)																																		
9	F-08	Multi-stage-speed fourth speed setting	Speed-4 000.0 Hz	0	0 to 375 (Hz)																																		
10	F-09	Multistage-speed fifth speed setting	Speed-5 000.0 Hz	0	0 to 375 (Hz)																																		
11	F-10	Multistage-speed sixth speed setting	Speed-6 000.0 Hz	0	0 to 375 (Hz)																																		
12	F-11	Multistage-speed seventh speed setting	Speed-7 000.0 Hz	0	0 to 375 (Hz)																																		
13	F-12	DC braking frequency adjustment	E-DCB 000.5 Hz	0.5	0.5 to 375 (Hz)	Set the starting frequency to perform DC braking.																																	
14	F-13	DC braking force adjustment	V-DCB 000	000	000 to 020	Set the DC braking force Maximum is at 020.																																	

Display sequence	No.	Function name	Display content (Function mode 2)	Standard setting	Setting range	Remarks
15	F-14	DC braking time adjustment	T-DCB 000.0 S	0 (s)	00 to 600 (S)	Set the DC braking time. If 0 is set, no DC braking.
16	F-15	Electronic thermal level adjustment	E-therm 100%	100 (%)	120 to 20 (%)	
17	F-16	Acceleration selection (Linear, S-curve)	ACcline Linear	Linear	Linear	
18	F-17	Deceleration selection (Linear, S-curve)	DEcline Linear	Linear	S-curve	
19	F-18	External frequency setting start	E-START 000.0 Hz	0 (Hz)	0 to 375 (Hz)	Set the relationship of the output frequency against the frequency setting from the terminal. F-START: Minimum set frequency F-END: Maximum set frequency
20	F-19	External frequency setting end	E-END 000.0 Hz	0 (Hz)	0 to 375 (Hz)	
21	F-20	Switch selection 1	SWITCH1 DCB OFF	See the left	DCB ON/OFF	① DC braking Yes/No
			SWITCH1 FM ANA		FM ANA/DIG	② Frequency monitor: Analog meter/Digital meter
			SWITCH1 fmax 120		Imax 120/360	③ Switch the maximum frequency 120/360 Hz
			SWITCH1 PWER ALM		PWER ALM/ZST	④ Trip/Retry function (Restart upon undervoltage) (*2)
			SWITCH1 DIOP FWD		DIOP FWD/REV	⑤ Switch the motor revolution direction with the digital operator
			SWITCH1 FWD ON		FWD ON/OFF	⑥ Direction of the motor revolution ON/OFF (Forward)
			SWITCH1 REV ON		REV ON/OFF	⑦ Direction of the motor revolution ON/OFF (Reverse)
			SWITCH1 OLMT ON		OLMT ON/OFF	⑧ Overload limiter

Display sequence	No.	Function name	Display content (Function mode 2)	Standard setting	Setting range	Remarks
22	F-21	Switch selection 2	SWITCH2 DB LVL	See the left	DB EDG/LVL	① DC braking edge/level selection
			SWITCH2 STOP ON		STOP ON/OFF	② STOP key is effective when external run is selected.
			SWITCH2 Ethm 100		Ethm 000/100	③ Electronic Thermal relay is selected.
			SWITCH2 SLOK OFF		SLOK OFF/ON	④ Setting frequency in software lock (Invalid from the terminal)
			SWITCH2 AIN 5V		AIN 5V/10V	⑤ Setting voltage for analog input. NOTE: Even if either VOL or CUR is selected, the total output frequency of both analog input signals is displayed.
23	F-22	Switch selection 3	SWITCH2 AIN TER	AIN TER/PAN	⑥ Be sure to select TER.	
			SWITCH3 SOFTFREE	SOFT LOCK/FREE	① Data is changed or not. (* 3)	
			SWITCH3 FARV 2	FARV 1/2	② Selection of frequency arrival (2: Set frequency 1: Any frequency)	
			SWITCH3 TRIP OFF	TRIP OFF/ON	③ Selection of neglect of undervoltage trip upon stop	
			SWITCH3 DEBG OFF	DEBG OFF/ON	④ Must be OFF.	
24	F-23	Switch selection 4	SWITCH3 TCNT CNT	CNT/CLR	⑤ Trip history clear selection	
			SWITCH4 MON FM	MON FM/CUR	Monitoring selection FM: Frequency monitoring CUR: Current monitoring	
25	F-24	Switch selection 5	SWITCH4 MON FM	MON FM/CUR	Monitoring selection FM: Frequency monitoring CUR: Current monitoring	
			SWITCH5 RUN 1	RUN 1/2	① RUN signal output selection 1: Output during operation 2: Output during operation and DC braking	
			SWITCH5 AVR ON	AVR ON/OFF	② AVR value delection for deceleration ON: The AVR value is the same as the V-SET value. OFF: An optional AVR value can be delected by DEC-V	
			SWITCH5 LAD ON	LAD ON/OFF	③ LAD stop function selection ON: LAD stop sunction (*4) OFF: No LAD stop function	
			SWITCH5 RVS ON	RVS ON/OFF	④ Reduced voltage start ON/OFF	

Display sequence	No.	Function name	Display content (Function mode 2)	Standard setting	Setting range	Remarks
26	F-25	Overload limiter constant setting	<u>LM</u> .CONS 150%01.0	150 (%) /1.0	50 to 150 (%) /0.3 to 31.0 (* 5)	Set the overload limit level and deceleration time
27	F-26	Allowable undervoltage time setting	<u>IPS</u> -T 001.0 S	1.0 (S)	0.3 to 3.0 (S)	
28	F-27	Standby time after undervoltage setting	<u>IPS</u> -R-T 0010.0 S	10.0 (S)	0.3 to 100.0 (S)	
29	F-28	Dynamic braking usage ratio setting	<u>BRD</u> -%ED 05.0%	5.0 (%)	0.1 to 31.0 (%) (* 6)	Set the allowable usage ratio of regenerative resistor to over 100 seconds
30	F-29	Frequency arrival setting	<u>SPD</u> -ARV ACC100%	ACC 100%	ACC or DEC 0 to 100 %	Rate to the maximum frequency which is set in Item F-00 or F-01
31	F-30	Carrier frequency setting	<u>CARRIER</u> 16 kHz	16	5, 8, 12, 16 (kHz)	
32	F-31	Input voltage setting	<u>V</u> -SET 220V	220 (380)	200, 220, 230, 240 V [ 380, 400, 415, 440, 460, 480 ]	Set the motor voltage (* 7)
33	F-32	AVR voltage selection for deceleration	<u>DEC</u> -V 220V	220 (380)	200, 220, 230, 240, 250, 270, 000 V [ 380, 400, 415, 440, 460, 480, 500, 540, 000 ]	This is effective when AVR OFF is selected in Item of Switch selection 5. *When AVR OFF is selected, the cursor will not move. (* 7)
34	F-33	Jump frequency 1	<u>JUMP</u> -F1 000.0Hz	0	0 to 375 (Hz)	Up to 3 locations can be set. 0 means invalid.
35	F-34	Jump frequency 2	<u>JUMP</u> -F2 000.0Hz	0	0 to 375 (Hz)	
36	F-35	Jump frequency 3	<u>JUMP</u> -F3 000.0Hz	0	0 to 375 (Hz)	
37	F-36	Jump frequency width	<u>JMP</u> -WID 0.5Hz	0.5	0 to 9.9 (Hz)	
38	F-37	Overload previous notice level	<u>OL</u> alarm 150%	150	50 to 150 (%)	ON level of overload previous notice signal
39	F-38	Input terminal 1	<u>IN</u> -TM 1 CF 1	Same as left	REV/CF1/CF2 CF3/DB/STN SET/2CH/FRS EXT/USP/RS SFT	REV: Reverse running command CF1: 1st multispeed switching CF2: 2nd multispeed switching CF3: 3rd multispeed switching DB: External DB input STN: Initialization SET: 2nd setting function switching 2CH: 2-stage acceleration and deceleration switching
		Input terminal 2	<u>IN</u> -TM 2 CF 2			
		Input terminal 3	<u>IN</u> -TM 3 2CH			
		Input terminal 4	<u>IN</u> -TM 4 RS			
		Input terminal 5	<u>IN</u> -TM 5 REV			
		Input terminal 1 NO/NC setting	<u>IN</u> -TM O/C-1 NO	NO	NO/NC	FRS: Free run input EXT: External trip terminal USP: USP function RS: Reset input SFT: Software lock input NO: a contact NC: b contact When the corresponding terminal is the [RS] terminal, only the NO operation is performed. (Even when NC is set, * display remains but the setting is returned to NO.)
		Input terminal 2 NO/NC setting	<u>IN</u> -TM O/C-2 NO			
		Input terminal 3 NO/NC setting	<u>IN</u> -TM O/C-3 NO			
		Input terminal 4 NO/NC setting	<u>IN</u> -TM O/C-4 NO			
Input terminal 5 NO/NC setting	<u>IN</u> -TM O/C-5 NO					



Display sequence	No.	Function name	Display content (Function mode 2)	Standard setting	Setting range	Remarks
40	F-39 Intelligent terminal output terminal setting	Output terminal 11	OUT-TM 1 AR	AR	AR/RUN/OL	AR: Speed arrival signal RUN: During on-line signal OL: Overload previous notice signal NO: a contact NC: b contact
		Output terminal 11 NO/NC setting	OUT-TM O/C-1 NC	NC	NO/NC	
		Alarm output NO/NC setting	OUT-TM O/C-A NC	NC		
41	F-40	External frequency command input sampling count setting	SAMP-F 08	08	1 to 8 (times)	When the frequency is low, the external frequency command may malfunction due to noise.

- (\*1) In the case of standard setting, up to 135 Hz (120 Hz + 15 Hz) can be set. When (3) the maximum frequency to be switched by Switch Selection 1 in the standard mode F-20 is set to 360 Hz, up to 375 Hz (360 Hz + 15 Hz) can be set.  
When a high frequency is to be selected, please sufficiently examine the mechanical strength of the motor and load. Particularly the general purpose motor is designed at 50 or 60 Hz. Therefore, when the running frequency is more than it, contact the manufacturer of motor beforehand.
- (\*2) In the case of retry, the starting frequency is 0.
- (\*3) Even in the enabled state, when the software lock terminal [SFT] is on, the equipment is in the disabled state.
- (\*4) When the current becomes more than 150% of the rating of load current, the acceleration and deceleration will be halted.
- (\*5) When the deceleration time is set to 31.0 by F-25 LM CONS, this function will not be performed.
- (\*6) When F-28 BRD-%ED is set to 31%, the damping circuit will not be operated.
- (\*7) When F-24 switch 5 AVR is ON, the value of F-32 DEC-V is forcibly set to the value of F-31 V-SET.



Protective function displayed when using the remote operator

Description	Contents	Display	
Power module protection	When output of an inverter is short circuited or the motor is locked, a large current flows through the inverter and causes a fault. When the current flowing through the power module or a temperature abnormality of the main devices comes to certain level, the output is cut off.	Constant speed	PM. Drive
		Dec.	PM. Decel
		Acc.	PM. Accel
		Stop	PM. ERR
Over-current protection (NOTE1)	The output current of the inverter is detected. When it exceeds the specified value, the output is turned off.	Constant speed	OC. Drive
		Dec.	OC. Decel
		Acc.	OC. Accel
		Stop	OC. ERR
Overload protection (NOTE1)	When a motor overload is detected the inverter's built in thermostat detects it and the output of the inverter is cut off.	Over. L	
Braking resistor overload	When regenerative braking resistor exceeds the usage time ratio, an overvoltage caused by the stop of the BRD function is detected, and output of the inverter is cut off.	OL. BRD	
Over-voltage protection	When the converter voltage exceeds a certain level due to regenerative energy from the motor, this protection function engages, and the output of inverter is cut off.	Over. V	
	This is an error display when the voltage supplied to the inverter exceeds the specified value.	OV. SRC	
EEPROM error	When the memory built in has problem by noise and excessive temperature rise, protective function works and output of inverter is cut off.	EEPROM	
Under-voltage protection	A decrease of the input voltage of an inverter results in improper function of the control circuit. It also generates motor heat and causes low torque. Output is cut off when the input voltage goes down to less than a 150 to 160V (200V class), 300 to 320V (400V class).	Under. V	
CT error	When a large noise source is near the inverter or an abnormality occurs on built-in CT, the output of the inverter is cut off.	CT	
CPU error	Malfunction or abnormality on built in CPU and the output of the inverter is cuts off.	CPU	
External trip	An abnormality signal from external equipment cuts off the output of the inverter. (When the external trip function is selected)	EXTERNAL	
USP error	It indicates an error when power is turned on while the inverter is being run. (When USP function is selected)	USP	
Ground fault protection	The inverter is protected by detection of ground fault between the inverter output and the motor upon power on. There may be the possibility of power module failure.	GND Flt	

NOTE 1: If a trip occurs, press the reset key after an elapse of 10 seconds to restore the inverter.

Remote operator/Copy unit

Dimension (unit:mm)

Remote operator (DOP-0A)

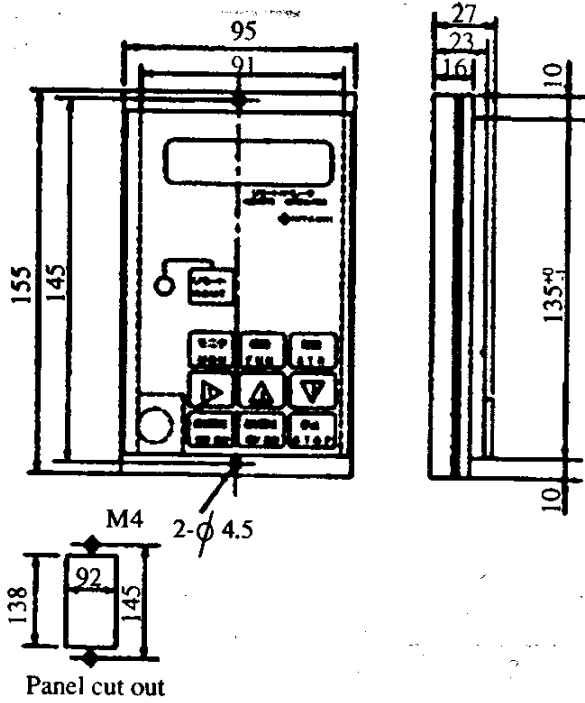

Copy unit (DRW-0A)

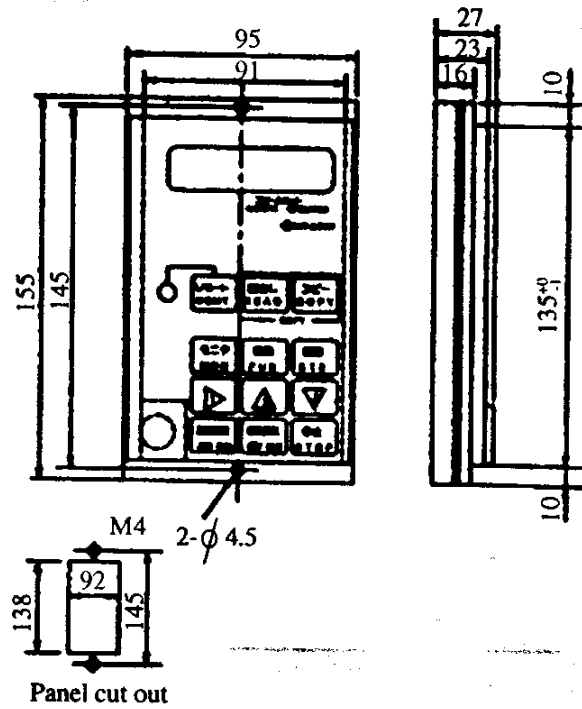

J100 CABLE

Extension cable for connector between the J100 and the remote operator

(ICJ-1, ICJ-3)

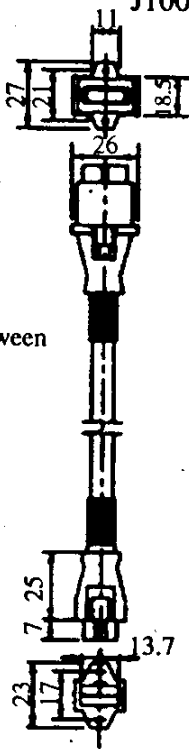

Extension cable for connector between the J100 and the remote operator or the copy unit

(ICA-1J, ICA-3J)

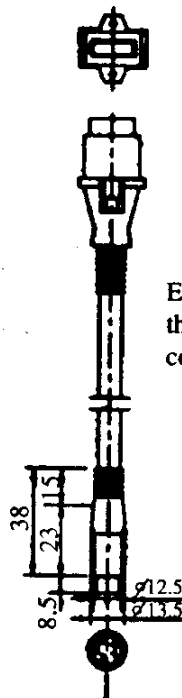

**NOTE 1:** Shape of the cable for the J100 series is different from that of the VWS3A and VWA. Only the cable can be provided when changing the cable.

## Copy unit function

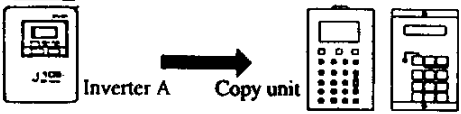
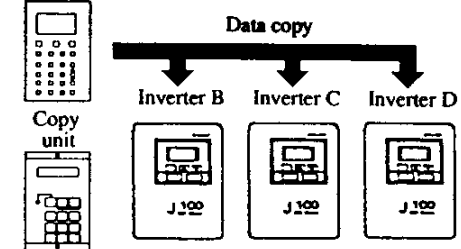
Operation example (Procedure to transfer the data of inverter A to B,C, and D inverters)			
Se-quence	Operation	Key	Operation result
1	Set data is read out from the inverter A (It is stored into the memory).	読出し READ	
2	Turn off the power supply to inverter A and remove the cable.	—	—
3	Connect the cable to inverter B and turn on the power.	—	—
4	Copy data stored in the copy unit is written to inverter B.	コピー COPY (* 1)	
5	Cut off the power supply to inverter B. (* 1)	—	
6	Perform the above processes from 3 to 5 sequentially for inverters C and D. That is, the same process as at for inverter B.	—	

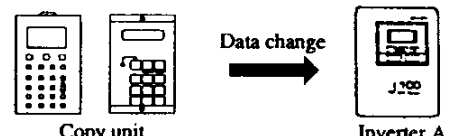
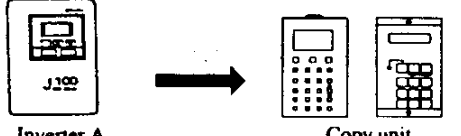
Operation example (Process to change and transfer to inverters B, C and D)			
1	Connect the cable and press the remote key. Change the data of the inverter with copy unit.	モニター MON   機能 FUN   記憶 STR	
2 to 6	Read out the data from inverter A (It is stored into the memory area of the copy unit). The following procedures are the same those of the operation 1. Change the data setting first.	読出し READ	

\*1 When pressing any key or resetting the unit after the  key is pressed, be sure to wait for at least six seconds. (When any key is pressed, the unit is reset, or the power is turned off within six seconds, the data may not be copied.)

**NOTE 1:** The following settings cannot be copied by the copy function. Note that the current set data is saved as it is.

- **Monitor mode**
  - Analog meter adjustment
  - Trip history monitor  
(Counts of latest three alarms)
  
- **Function mode**
  - F-23 Switch selection 4
  - F-24 Switch selection 5
  - F-32 AVR voltage selection for deceleration
  - F-33 Jump frequency 1
  - F-34 Jump frequency 2
  - F-35 Jump frequency 3
  - F-36 Jump frequency width
  - F-37 Overload previous notice level
  - F-38 Intelligent input terminal setting
  - F-39 Intelligent output terminal setting
  - F-40 Setting of external frequency command sampling times

**NOTE 2:** Do not copy the setting from the 200 V class to the 400 V class or from the 400 V class to the 200 V class. (When the setting is copied to a different voltage class by mistake, reset F-31 V-SET (motor voltage setting).)

**NOTE 3:** Do not copy the setting from the Japanese version to the European or American version or from the European or American version to the Japanese version.

**NOTE 4:** When the V/f control setting data is copied from a different capacity (for example, copied from J100-004SFE5 to J100-022SFE5), change the kW setting of F-00 CONTROL to the kW value of the applied motor.

## 14. SERVICE

When inquiring about inverter trouble, please be ready to inform the shop where you purchased your unit or the nearest service station the following.

- (1) Type
- (2) Purchased date
- (3) Manufacturing No. (MFG. No.)
- (4) Malfunction symptoms

If the contents are unclear due to an old nameplate, give only the clear items. To reduce the non-operation time, it is recommended to stock a spare inverter.

### Warranty

The warranty period under normal installation and handling conditions shall be one (1) year after the date of delivery. The warranty shall cover the repair of only the inverter to be delivered.

1. Service in the following cases, even within the warranty period, shall be charged to the purchaser.
  - (a) Malfunction or damage caused by misoperation or remodelling or improper repair
  - (b) Malfunction or damage caused by a drop after purchase and transportation
  - (c) Malfunction or damage caused by fire, earthquake, flood, thunderbolt, or other natural calamities, pollution or abnormal voltage.
2. When service is required for the product at your worksite, all expenses associated with field repair shall be charged to the purchaser.
3. Always keep it handy. Please do not lose it. We are sorry but this manual can not be re-issued.

## Appendix 1 J100 series data setting values

J100 series inverters provide many functions and their parameters can be set by the user. It is recommended to record the parameters that have been set by the user, in order to speed the investigation and repair in the event of a failure.

Inverter model J100   
 MFG. No.

This information is written on the nameplate located on the side cover of the inverter.

### For the digital operator

Display sequence	Function name	Standard setting	Set value
F1	Setting frequency and output frequency	—	
F2	Setting output frequency	0.0	
F4	Direction of the motor revolution	F	
F5	Setting V/F pattern	08 (00)	
F6	Setting acceleration time	10.0 (15.0)	
F7	Setting deceleration time	10.0 (15.0)	
F8	Setting torque boost	11	
F9	Switch over of the digital operator and terminal mode	03	
F10	Analog meter adjustment	72	
F11	Setting input voltage	220 (380)	
F14	Setting extension function	0	

NOTE: The value in the parentheses is for 400 V.



(2) Extention Function Mode

Command display	Function name	Standard setting	Remarks
A 0	Control method	0	
A 1	Motor capacity setting	NOTE 1	
A 2	Motor poles setting	4	
A 3	Maximum frequency adjustment	0.0	
A 4	Start frequency adjustment	0.5	
A 5	Upper frequency limiter setting	0	
A 6	Lower frequency limiter setting	0	
A 7	Jump frequency setting 1	0	
A 8	Jump frequency setting 2	0	
A 9	Jump frequency setting 3	0	
A10	Carrier frequency setting	16	
A11	Frequency command sampling setting	8	
A12	Multispeed first speed setting	0	
A13	Multispeed second speed setting	0	
A14	Multispeed third speed setting	0	
A15	Multispeed forth speed setting	0	
A16	Multispeed fifth speed setting	0	
A17	Multispeed sixth speed setting	0	
A18	2-stage acceleration time setting	10.0	
A19	2-stage deceleration time setting	10.0	
A20	DC braking frequency setting	0.5	
A21	DC braking force adjustment	0	
A22	DC braking time adjustment	0	
A23	Electronic thermal level adjustment	100	
A24	Electronic thermal characteristic selection	1	
A26	External frequency setting start	0	
A27	External frequency setting end	0	
A28	Acceleration selection (Linear, S-curve)	0	
A29	Deceleration selection (Linear, S-curve)	0	
A30	Overload previous notice signal setting	150	
A31	Overload limit level setting	150	
A32	Overload limit content selection	0	
A33	LAD stop function setting	0	
A34	Trip/retry function selection	0	
A35	Trip ignorance selection	0	
A36	AVR voltage setting for deceleration	0	
A37	Motor voltage setting for deceleration	220 (380)	
A38	Dynamic braking usage ratio	5	
A39	Optional arrival frequency for acceleration	100	

Command display	Function name	Standard setting	Remarks
A 40	Optional arrival frequency for deceleration	100	
A41	Forward rotation	1	
A42	Reverse rotation	1	
A43	Stop key ON/OFF selection	0	
A48	Analog input selection	0	
A49	Frequency arrival signal output method	2	
A50	Analog/digital meter selection	1	
A51	Frequency/current monitoring selection	0	
A52	RUN signal output selection	1	
A53	Enable/disable of frequency setting for software lock	0	
A55	DC braking ON/OFF selection	0	
A56	DC braking edge/level selection	1	
A57	Trip history clear selection	0	
A58	Reduced voltage start selection	1	
A62	Base frequency setting	50	
A63	Maximum frequency setting	50	
A64	Maximum frequency switching	0	
A68	Jump frequency range setting	0.5	
A71	Multispeed seventh speed setting	0	
A80	Frequency command adjust. (voltage)	NOTE 2	
A81	Frequency command adjust.(current)	NOTE 2	
A82	Allowable undervoltage time setting	1.0	
A83	Undervoltage retry waiting time	10.0	
A84	Software lock selection	0	
A85	Deceleration rate setting for overload limit	1.0	
C0	Input terminal setting 1	1	
C1	Input terminal setting 2	2	
C2	Input terminal setting 3	7	
C3	Input terminal setting 4	11	
C4	Input terminal setting 5	0	
C10	Output terminal setting	0	
C20	Input terminal a and b contact setting	00	
C21	Output terminal a and b contact setting	03	

**NOTE 1:** The most applicable motor capacity of the inverter is set.

**NOTE 2:** The initial setting of each inverter is adjusted when shipped from the factory.

**NOTE 3:** The value in the parentheses is for 400 V standard setting.

## Appendix 2 J100 series data setting values (For the remote operator)

J100 series inverters provide many functions and their parameters can be set by the user. It is recommended to record the parameters that have been set by the user, in order to speed the investigation and repair in the event of a failure.

Inverter model J100

MFG. No.

This information is written on the nameplate located on the side cover of the inverter.

### Monitor mode

NO.	Monitor name	Display content	Set value
1	Frequency setting and output frequency	FS000.0 000.0Hz	
		1S005.0 000.0Hz	
	Multistage speed setting and output frequency	2S020.0 000.0Hz	
		3S040.0 000.0Hz	
		4S000.0 000.0Hz	
	Expansion multistage speed	5S000.0 000.0Hz	
		6S000.0 000.0Hz	
		7S000.0 000.0Hz	
2	Acceleration time setting	ACCEL-1 010.0S <small>(NOTE)</small>	
3	Deceleration time setting	DECEL-1 010.0S <small>(NOTE)</small>	
4	2-stage acceleration time setting	ACCEL-2 010.0S	
5	2-stage deceleration time setting	DECEL-2 010.0S	
6	Frequency setting command	F-SET-M Terminal	
7	Operation command method	F/R-SW Terminal	
8	Revolution speed display	RPM 4P 00000RPM	_____
9	Output current display	If - - - A Im000.0%	_____
10	DC current display	PN-V 000V	_____
11	Output voltage gain adjustment	V-Boost Code <11>	
12	Output voltage gain adjustment	V-Gain 100%	
13	Analog meter adjustment	M-ADJ 72	
14	Trip display	# <input type="text"/>	_____
		?ERROR Over V.	In case of over voltage tripping
15	Trip history	?ERR COUNT 000	_____

NOTE: The value of 400 V class is 15.0s.

## Function mode

Display sequence	Function name	Standard setting	Set value
F-00	V/F pattern setting	V/F-VC 050-050	
F-01	Maximum frequency adjustment	0	
F-02	Start frequency adjustment	0.5	
F-03	Maximum frequency limiter setting	0	
F-04	Minimum frequency limiter setting	0	
F-05	Multistage-speed first speed setting	0 (Hz)	
F-06	Multistage-speed second speed setting	0 (Hz)	
F-07	Multistage-speed third speed setting	0 (Hz)	
F-08	Multistage-speed fourth speed setting	0 (Hz)	
F-09	Multistage-speed fifth speed setting	0 (Hz)	
F-10	Multistage-speed sixth speed setting	0 (Hz)	
F-11	Multistage-speed seventh speed setting	0 (Hz)	
F-12	DC braking frequency adjustment	0.5 (Hz)	
F-13	DC braking force adjustment	0	
F-14	DC braking time adjustment	0 (S)	
F-15	Electronic thermal level adjustment	100 (%)	
F-16	Acceleration selection(Linear, Curve)	Linear	
F-17	Deceleration selection(Linear, Curve)	Linear	
F-18	External frequency setting start	0 (Hz)	
F-19	External frequency setting end	0 (Hz)	
F-20	Switch selection 1	Set DC braking	DCB OFF
		Switch of frequency monitor	FM ANA
		Switch of the maximum frequency	fmax 120
		Switch of trip and retry	PWER ALM
		Switch of the motor direction when using the digital operator	DIOP FWD
		Direction of the motor (Forward)	FWD ON
		Direction of the motor (Reverse)	REV ON
F-21	Switch selection 2	Overload limiter	OLMT ON
		DC braking edge/level selection	DB LVL
		[Stop]key is effective when external run is selected	STOP ON
		Selection of electronic thermal characteristic	Ethm 100
		Selection of software lock	SLOK OFF
		Setting voltage for analog input	AIN 5V
F-22	Switch selection 3	Selection of analog input	AIN TER
		Selection of data change	SOFTFREE
		Selection of frequency arrival	FARV 2
		Selection of neglect of trip	TRIP OFF
		Debug mode display	DEBG OFF
F-23	Switch selection 4	Trip history clear	TCNT CNT
		Monitoring selection	MON FM
F-24	Switch selection 5	RUN signal output selection	RUN 1
		AVR value selection for deceleration	AVR ON
		LAD stop function selection	LAD ON
		Selection of reduced voltage start	RVS ON
F-25	Overload limiter constant	150% 1.0	
F-26	Allowable undervoltage time	001.0S	
F-27	Stand by time after undervoltage setting	0010.0S	
F-28	Dynamic braking usage ratio setting	5.0	
F-29	Frequency arrival setting	ACC, DEC 100%	ACC DEC
F-30	Carrier frequency setting	16 kHz	
F-31	Input voltage setting	220 V (380V)	
F-32	AVR voltage setting for deceleration	220 V (380V)	

Display sequence	Function name	Standard setting	Set value
F-33	Jump frequency 1	0	
F-34	Jump frequency 2	0	
F-35	Jump frequency 3	0	
F-36	Jump frequency width	0.5	
F-37	Overload previous notice level	150%	
F-38	Intelligent terminal input terminal setting	Input terminal 1	CF1
		Input terminal 2	CF2
		Input terminal 3	2CH
		Input terminal 4	RS
		Input terminal 5	REV
		Input terminal 1 NO/NC setting	NO
		Input terminal 2 NO/NC setting	NO
		Input terminal 3 NO/NC setting	NO
		Input terminal 4 NO/NC setting	NO
		Input terminal 5 NO/NC setting	NO
F-39	Intelligent terminal output terminal setting	Output terminal I1	AR
		Output terminal I1 NO/NC setting	NC
		Alarm output NO/NC setting	NC
F-40	External frequency command input sampling count setting	08	

### Appendix 3 Capacitor Life Curve

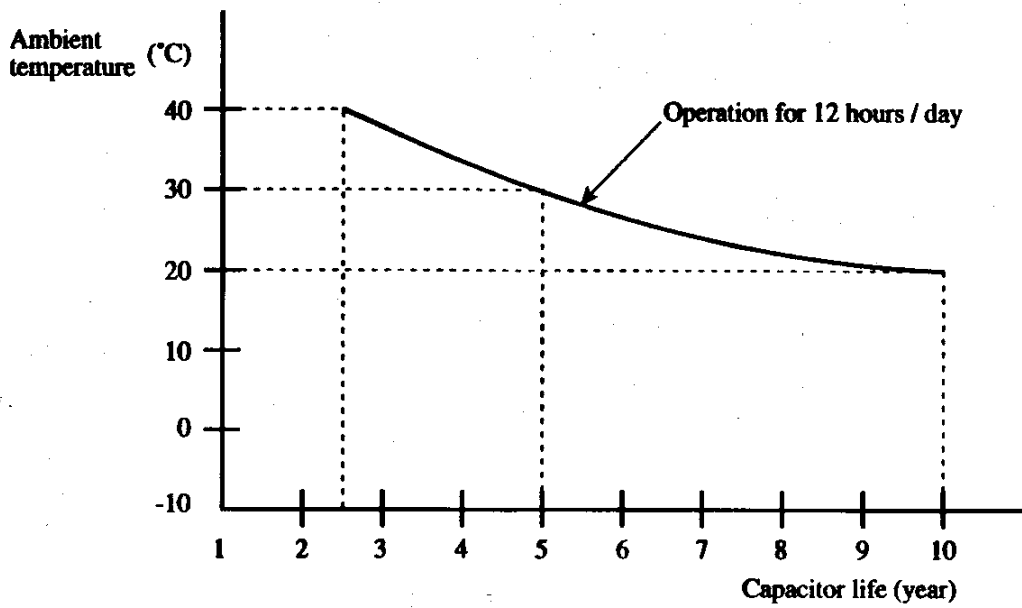

- \* When the inverter is stored in the panel, the ambient temperature is the temperature in the panel.
- \* The useful life of the inverter will shorten if proper ventilation is disturbed by the dust and dirt accumulated on the inverter. This is true even when the inverter is running at a normal operating temperature.