

# INVERTER

# FR-D700

# INSTALLATION GUIDELINE

**FR-D720S-008 to 100-EC**

**FR-D740-012 to 160-EC**

Thank you for choosing this Mitsubishi Inverter.  
Please read through this Installation Guideline and the enclosed CD ROM to operate this inverter correctly.  
Do not use this product until you have a full knowledge of the equipment, the safety information and the instructions.  
Please forward this Installation Guideline and the CD ROM to the end user.

## CONTENTS

<b>[1]</b>	<b>INSTALLATION OF THE INVERTER AND INSTRUCTIONS .....</b>	<b>1</b>
<b>[2]</b>	<b>OUTLINE DIMENSION DRAWING .....</b>	<b>3</b>
<b>[3]</b>	<b>WIRING .....</b>	<b>4</b>
<b>[4]</b>	<b>PRECAUTIONS FOR USE OF THE INVERTER .....</b>	<b>10</b>
<b>[5]</b>	<b>FAILSAFE OF THE SYSTEM WHICH USES THE INVERTER .....</b>	<b>12</b>
<b>[6]</b>	<b>PARAMETER .....</b>	<b>13</b>
<b>[7]</b>	<b>TROUBLESHOOTING .....</b>	<b>18</b>

*D*  
*700*

Print Date		Manual Number	Revision
02/2008	pdp-gb	213451-A	First edition
10/2008	pdp-akl	213451-B	Additions • FR-D720S-008 to 100
02/2010	pdp-gb	213451-C	Product safety hazard notice Usage of a residual current device



**For Maximum Safety**

- Mitsubishi transistorized inverters are not designed or manufactured to be used in equipment or systems in situations that can affect or endanger human life.
- When considering this product for operation in special applications such as machinery or systems used in passenger transportation, medical, aerospace, atomic power, electric power, or submarine repeating applications, please contact your nearest Mitsubishi sales representative.
- Although this product was manufactured under conditions of strict quality control, you are strongly advised to install safety devices to prevent serious accidents when it is used in facilities where breakdowns of the product are likely to cause a serious accident.
- Please do not use this product for loads other than three-phase induction motors.
- Please check upon receiving of the inverter whether this Installation Guideline corresponds to the delivered inverter. Compare the specifications on the capacity plate with the specifications given in this Installation Guideline.

### This section is specifically about safety matters

Do not attempt to install, operate, maintain or inspect the inverter until you have read through this Installation Guideline and appended documents carefully and can use the equipment correctly. Do not use the inverter until you have a full knowledge of the equipment, safety information and instructions. In this Installation Guideline, the safety instruction levels are classified into "WARNING" and "CAUTION".



#### WARNING

Assumes that incorrect handling may cause hazardous conditions, resulting in death or severe injury.



#### CAUTION

Assumes that incorrect handling may cause hazardous conditions, resulting in medium or slight injury, or may cause physical damage only.

Note that even the **CAUTION** level may lead to a serious consequence according to conditions. Please follow strictly the instructions of both levels because they are important to personnel safety.

### Product Safety

#### WARNING

The drawing on page 6 in the English manual "Safety stop function instruction manual for FR-D700 Transistorized Inverter (BCN-A211508-000-C)" contains an error that might result in an unsafe state when using the function "Safety stop torque". This risk exists when several FR-D700 inverters are connected in parallel to a safety relay. There is a detailed explanation of the error in the notice on product safety (Ref.: PSN2009-0001b-DE), as well as a description of correct configuration.

### Electric Shock Prevention

#### WARNING

- While power is on or when the inverter is running, do not open the front cover or wiring cover. Otherwise you may get an electric shock.
- Do not run the inverter with the front cover removed. Otherwise, you may access the exposed high-voltage terminals or the charging part of the circuitry and get an electric shock.
- Even if power is off, do not remove the front cover except for wiring or periodic inspection. You may access the charged inverter circuits and get an electric shock.
- Before starting wiring or inspection, check to make sure that the operation panel indicator is off, wait for at least 10 minutes after the power supply has been switched off, and check that there are no residual voltage using a tester or the like. The capacitor is charged with high voltage for some time after power off and it is dangerous.
- This inverter must be earthed (grounded). Earthing (Grounding) must conform to the requirements of national and local safety regulations and electrical codes. (NEC section 250, IEC 536 class 1 and other applicable standards)
- Any person who is involved in the wiring or inspection of this equipment should be fully competent to do the work.
- Always install the inverter before wiring. Otherwise, you may get an electric shock or be injured.
- If your application require by installation standards a RCD (residual current device) as up stream protection please select according to DIN VDE 0100-530 as following:  
Single phase inverter type A or B  
Three phase inverter only type B  
(Additional instructions on the use of a residual current device are contained on *page 20*.)
- Perform setting dial and key operations with dry hands to prevent an electric shock. Otherwise you may get an electric shock.
- Do not subject the cables to scratches, excessive stress, heavy loads or pinching. Otherwise you may get an electric shock.
- Do not replace the cooling fan while power is on. It is dangerous to replace the cooling fan while power is on.
- Do not touch the printed circuit board with wet hands. You may get an electric shock.
- When measuring the main circuit capacitor capacity, the DC voltage is applied to the motor for 1 s at powering off. Never touch the motor terminal, etc. right after powering off to prevent an electric shock.

### Fire Prevention

#### CAUTION

- Mount the inverter to incombustible material. Install the inverter on a nonflammable wall without holes (so that nobody can touch the inverter heatsink on the rear side, etc.). Mounting it to or near combustible material can cause a fire.
- If the inverter has become faulty, switch off the inverter power. A continuous flow of large current could cause a fire.
- When using a brake resistor, make up a sequence that will turn off power when an alarm signal is output. Otherwise, the brake resistor may excessively overheat due to damage of the brake transistor and such, causing a fire.
- Do not connect a resistor directly to the DC terminals +, -. This could cause a fire and destroy the inverter. The surface temperature of braking resistors can far exceed 100 °C for brief periods. Make sure that there is adequate protection against accidental contact and a safe distance is maintained to other units and system parts.

### Injury Prevention

#### CAUTION

- Apply only the voltage specified in the instruction manual to each terminal. Otherwise, burst, damage, etc. may occur.
- Ensure that the cables are connected to the correct terminals. Otherwise, burst, damage, etc. may occur.
- Always make sure that polarity is correct to prevent damage, etc. Otherwise, burst, damage, etc. may occur.
- While power is on or for some time after power-off, do not touch the inverter as it is hot and you may get burnt.

## Additional Instructions

Also note the following points to prevent an accidental failure, injury, electric shock, etc.

### Transportation and installation

#### CAUTION

- Transport the product using the correct method that corresponds to the weight. Failure to observe this could lead to injuries.
- Do not stack the inverter boxes higher than the number recommended.
- Ensure that installation position and material can withstand the weight of the inverter. Install according to the information in the instruction manual.
- Do not install or operate the inverter if it is damaged or has parts missing. This can result in breakdowns.
- When carrying the inverter, do not hold it by the front cover or setting dial; it may fall off or fail.
- Do not stand or rest heavy objects on the product.
- Check the inverter mounting orientation is correct.
- Prevent other conductive bodies such as screws and metal fragments or other flammable substance such as oil from entering the inverter.
- As the inverter is a precision instrument, do not drop or subject it to impact.
- Use the inverter under the following environmental conditions. Otherwise, the inverter may be damaged.

Operating condition	Ambient temperature	-10 °C to +50 °C (non-freezing)
	Ambient humidity	90 % RH or less (non-condensing)
	Storage temperature	-20 °C to +65 °C ①
	Atmosphere	Indoors (free from corrosive gas, flammable gas, oil mist, dust and dirt)
	Altitude	Maximum 1000 m above sea level for standard operation. After that derate by 3 % for every extra 500 m up to 2500 m (91 %).
	Vibration	5.9 m/s <sup>2</sup> or less at 10 to 55 Hz (directions of X, Y, Z axes)

① Temperature applicable for a short time, e.g. in transit.

### Wiring

#### CAUTION

- Do not install assemblies or components (e. g. power factor correction capacitors) on the inverter output side, which are not approved from Mitsubishi.
- The direction of rotation of the motor corresponds to the direction of rotation commands (STF/STR) only if the phase sequence (U, V, W) is maintained.

### Test operation and adjustment

#### CAUTION

- Before starting operation, confirm and adjust the parameters. A failure to do so may cause some machines to make unexpected motions.

### Operation

#### WARNING

- When you have chosen the retry function, stay away from the equipment as it will restart suddenly after an alarm stop.
- Since pressing  key may not stop output depending on the function setting status, provide a circuit and switch separately to make an emergency stop (power off, mechanical brake operation for emergency stop, etc).
- Make sure that the start signal is off before resetting the inverter alarm. A failure to do so may restart the motor suddenly.
- The inverter can be started and stopped via the serial port communications link or the field bus. However, please note that depending on the settings of the communications parameters it may not be possible to stop the system via these connections if there is an error in the communications system or the data line. In configurations like this it is thus essential to install additional safety hardware that makes it possible to stop the system in an emergency (e.g. controller inhibit via control signal, external motor contactor etc). Clear and unambiguous warnings about this must be posted on site for the operating and service staff.
- The load used should be a three-phase induction motor only. Connection of any other electrical equipment to the inverter output may damage the inverter as well as the equipment.
- Do not modify the equipment.
- Do not perform parts removal which is not instructed in this manual. Doing so may lead to fault or damage of the inverter.

### **⚠ CAUTION**

- The electronic thermal relay function does not guarantee protection of the motor from overheating. It is recommended to install both an external thermal and PTC thermistor for overheat protection.
- Do not use a magnetic contactor on the inverter input for frequent starting/stopping of the inverter. Otherwise, the life of the inverter decreases.
- Use a noise filter to reduce the effect of electromagnetic interference and follow the accepted EMC procedures for proper installation of frequency inverters. Otherwise nearby electronic equipment may be affected.
- Take appropriate measures regarding harmonics. Otherwise this can endanger compensation systems or overload generators.
- When a 400 V class motor is inverter-driven, please use an insulation-enhanced motor or measures taken to suppress surge voltages. Surge voltages attributable to the wiring constants may occur at the motor terminals, deteriorating the insulation of the motor.
- When parameter clear or all clear is performed, set again the required parameters before starting operations. Each parameter returns to the initial value.
- The inverter can be easily set for high-speed operation. Before changing its setting, fully examine the performances of the motor and machine.
- The DC braking function of the frequency inverter is not designed to continuously hold a load. Use an electro-mechanical holding brake on the motor for this purpose.
- Before running an inverter which had been stored for a long period, always perform inspection and test operation.
- For prevention of damage due to static electricity, touch nearby metal before touching this product to eliminate static electricity from your body.

#### **Emergency stop**

### **⚠ CAUTION**

- Provide a safety backup such as an emergency brake which will prevent the machine and equipment from hazardous conditions if the inverter fails.
- When the breaker on the inverter primary side trips, check for the wiring fault (short circuit), damage to internal parts of the inverter, etc. Identify the cause of the trip, then remove the cause and power on the breaker.
- When the protective function is activated (i. e. the frequency inverter switches off with an error message), take the corresponding corrective action as described in the inverter manual, then reset the inverter, and resume operation.

#### **Maintenance, inspection and parts replacement**

### **⚠ CAUTION**

- Do not carry out a megger (insulation resistance) test on the control circuit of the inverter. It will cause a failure.

#### **Disposal of the inverter**

### **⚠ CAUTION**

- Treat as industrial waste.

#### **General instructions**

Many of the diagrams and drawings in instruction manuals show the inverter without a cover, or partially open. Never run the inverter in this status. Always replace the cover and follow this Installation Guideline when operating the inverter.



# 1 INSTALLATION OF THE INVERTER AND INSTRUCTIONS

Unpack the inverter and check the capacity plate on the front cover and the rating plate on the inverter side face to ensure that the product agrees with your order and the inverter is intact.

## 1.1 Inverter Type

FR - D740 - 036 - EC

Symbol	Voltage Class	Symbol	Type number
D720S	Single-phase 200 V class	008 to 160	3-digit display
D740	Three-phase 400 V class		

### Capacity plate example

#### Capacity plate

FR-D740-036-EC ← Inverter type

SERIAL: XXXXXX ← Serial number

### Rating plate example

#### Rating plate

MITSUBISHI		INVERTER
Inverter type	MODEL	FR-D740-036-EC
Input rating	INPUT :	XXXXX
Output rating	OUTPUT :	XXXXX
Serial number	SERIAL :	
		PASSED

## 1.2 Installation of the inverter

### Enclosure surface mounting

Remove the front cover and wiring cover to fix the inverter to the surface.

FR-D720S-008 to 042

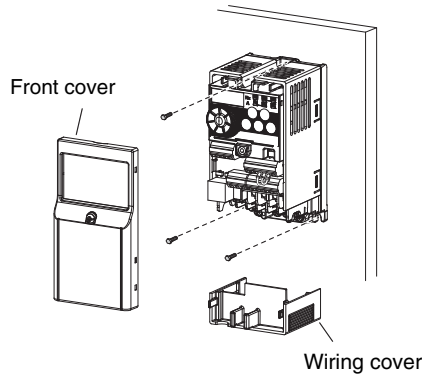

FR-D720S-070 and 100, FR-D740-012 to 160

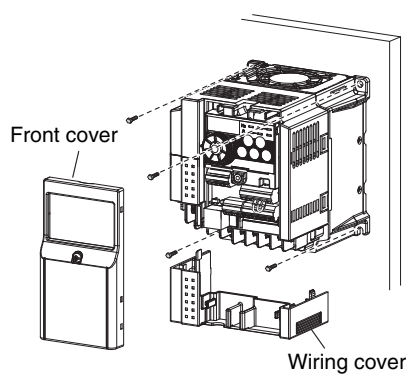

### Note

- When encasing multiple inverters, install them in parallel and leave clearance as a cooling measure.
- Install the inverter vertically.

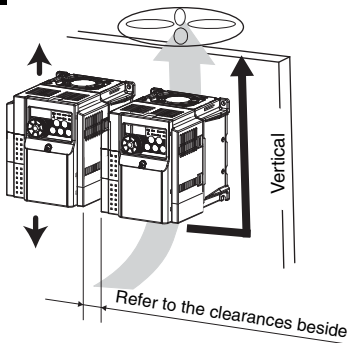

### Ambient temperature and humidity

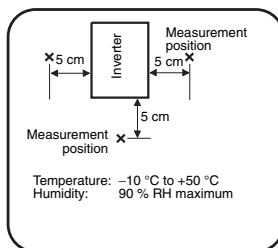

Leave enough clearances and take cooling measures.

### Clearances (side)

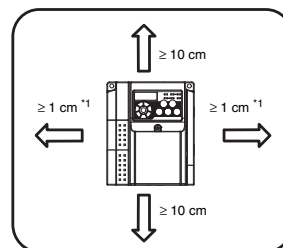

\*1 When using the inverters at the ambient temperature of 40 °C or less, the inverters can be installed closely attached (0 cm clearance).  
When ambient temperature exceeds 40 °C, clearances between the inverter should be 1 cm or more (5 cm or more for the FR-D740-120 or more).

### Clearances (front)

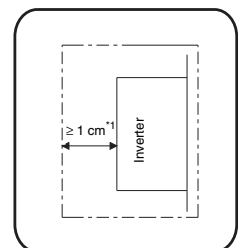

\*1 5 cm or more for the FR-D740-120 or more



### 1.3 General Precaution

The bus capacitor discharge time is 10 minutes. Before starting wiring or inspection, switch power off, wait for more than 10 minutes, and check for residual voltage between terminal + and – with a meter etc., to avoid a hazard of electrical shock.

### 1.4 Environment

Before installation, check that the environment meets following specifications.

<b>Ambient temperature</b>	-10 °C to +50 °C (non-freezing)
<b>Ambient humidity</b>	90 % RH or less (non-condensing)
<b>Atmosphere</b>	Free from corrosive and explosive gases, free from dust and dirt
<b>Maximum altitude</b>	Maximum 1000 m above sea level for standard operation. After that derate by 3 % for every extra 500 m up to 2500 m (91 %).
<b>Vibration</b>	5.9 m/s <sup>2</sup> or less at 10 to 55 Hz (directions of X, Y, Z axes)

#### CAUTION

- Install the inverter on a strong surface securely and vertically with bolts.
- Leave enough clearances and take cooling measures.
- Avoid places where the inverter is subjected to direct sunlight, high temperature and high humidity.
- Install the inverter on a non-combustible surface.

## 2 OUTLINE DIMENSION DRAWING

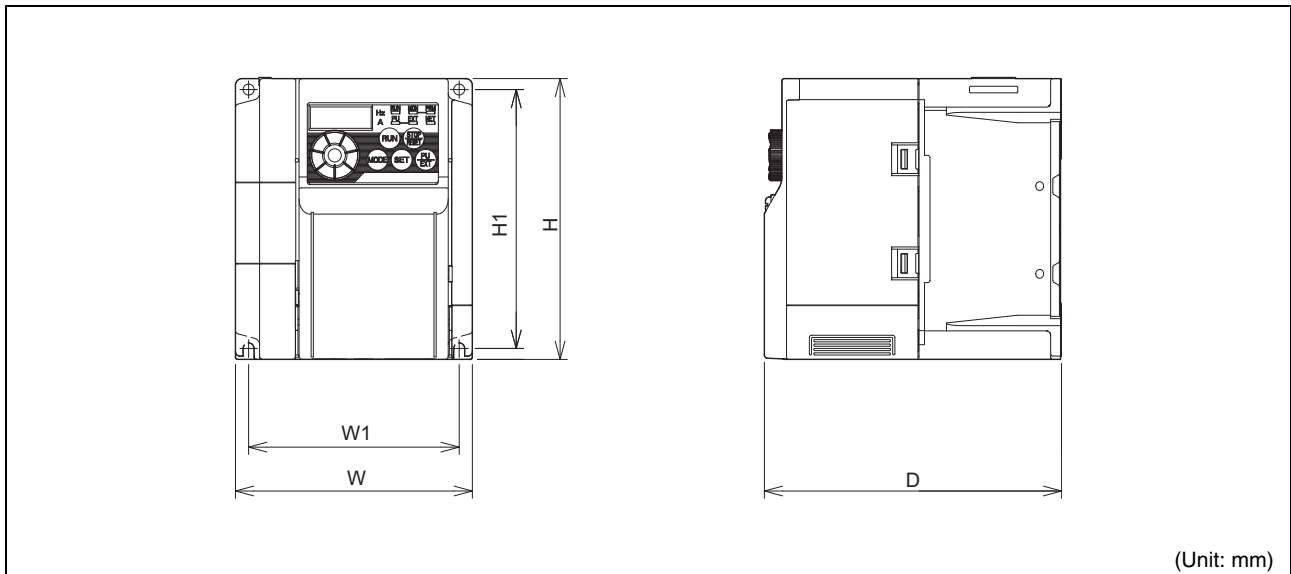

Inverter Type		W	W1	H	H1	D
200 V class	FR-D720S-008	68	56	128	118	80.5
	FR-D720S-014					142.5
	FR-D720S-025					162.5
	FR-D720S-042					155.5
	FR-D720S-070	108	96	150	138	145
	FR-D720S-100	140	128			
400 V class	FR-D740-012	108	96	128	118	129.5
	FR-D740-022					135.5
	FR-D740-036					155.5
	FR-D740-050					165.5
	FR-D740-080	220	208	150	138	155
	FR-D740-120					
	FR-D740-160					

# 3 WIRING

## 3.1 Terminal connection diagram

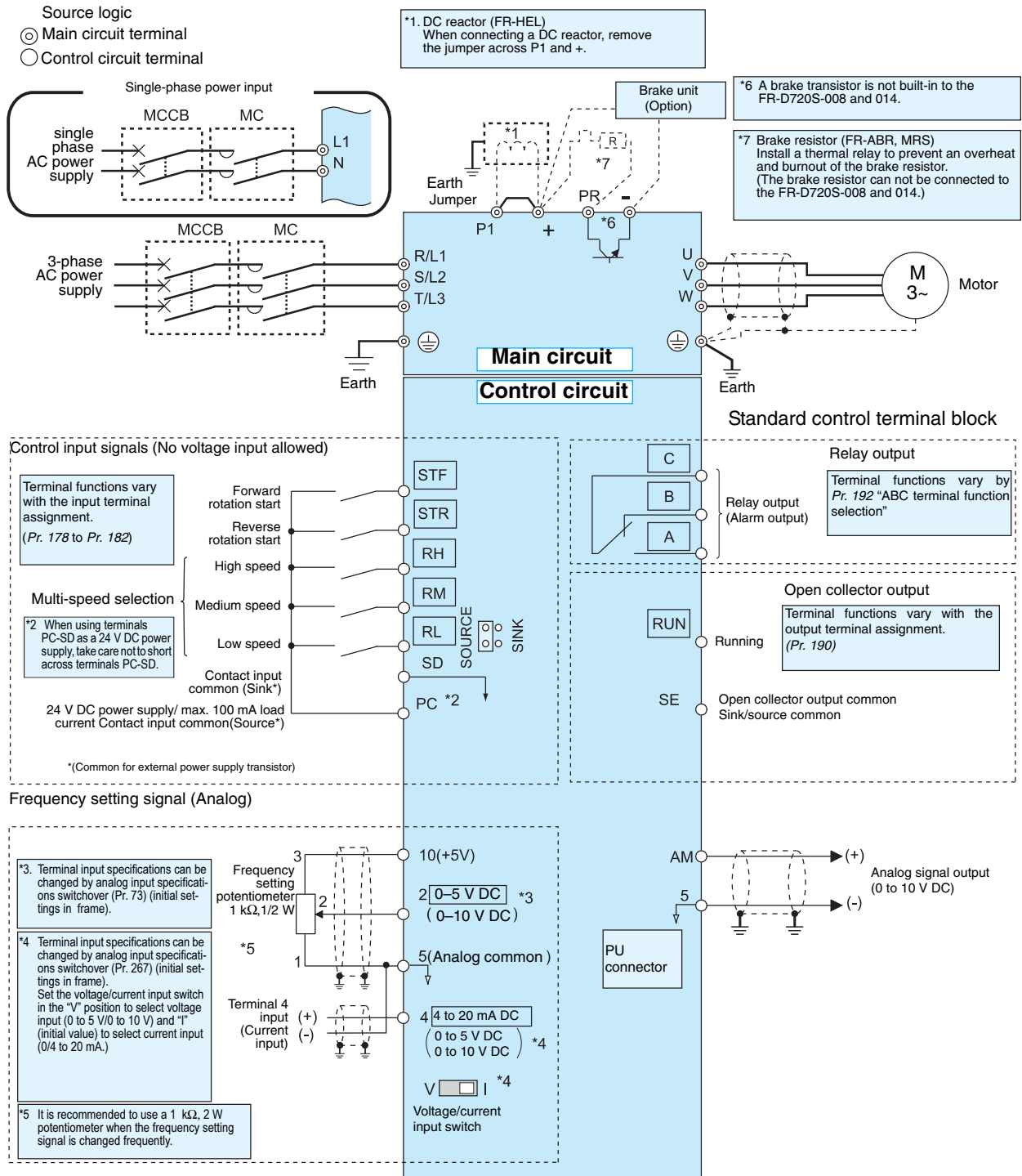

### CAUTION

- To prevent a malfunction due to noise, keep the signal cables more than 10 cm away from the power cables.
- After wiring, wire offcuts must not be left in the inverter. Wire offcuts can cause an alarm, failure or malfunction. Always keep the inverter clean. When drilling mounting holes in a control box etc., take care not to allow chips and other foreign matter to enter the inverter.
- Set the voltage/current input switch in the correct position. An incorrect setting may cause a fault, failure or malfunction.

## 3.2 Main circuit terminal specifications

### 3.2.1 Terminal arrangement of the main circuit terminal, power supply and the motor wiring

#### Single-phase 200 V class

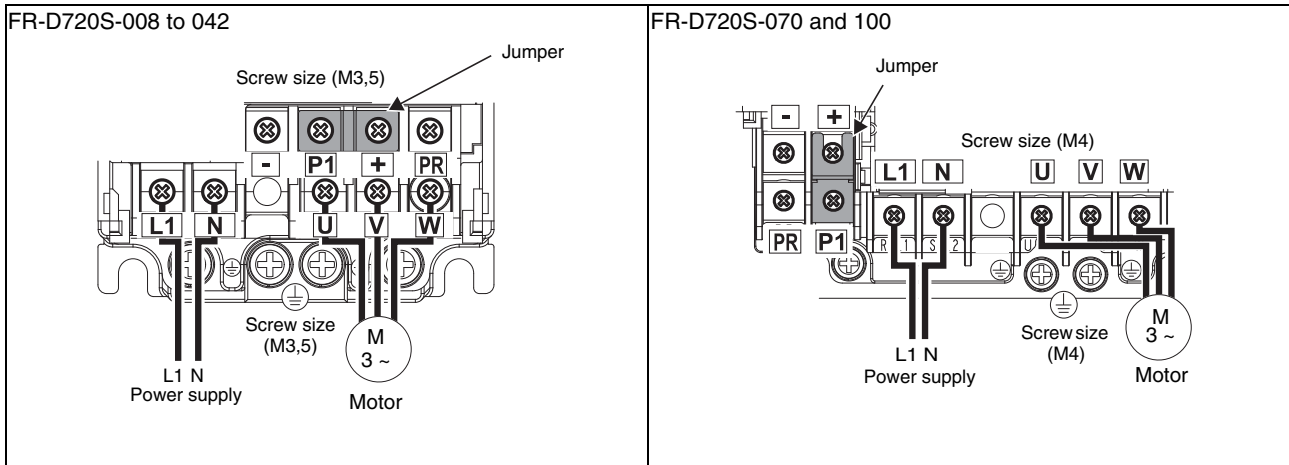

#### Three-phase 400 V class

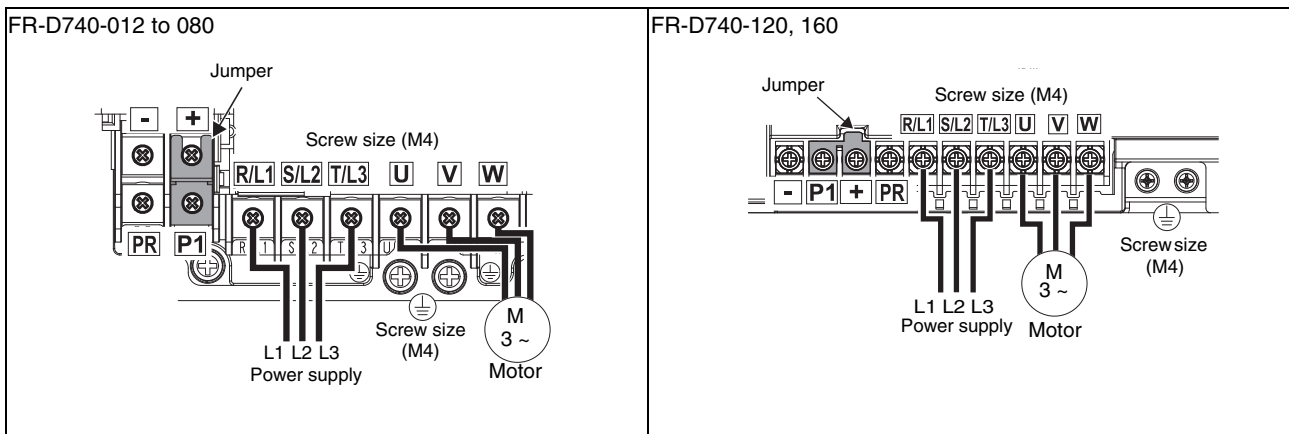

#### CAUTION

- Make sure the power cables are connected to the R/L1, S/L2, T/L3 (three-phase 400 V class) resp. to the L1, N (for single-phase 200 V class). Never connect the power cable to the U, V, W of the inverter. Doing so will damage the inverter. (Phase sequence needs not to be matched.)
- Connect the motor to U, V, W. At this time turning on the forward rotation switch (signal) rotates the motor in the clockwise direction when viewed on the motor shaft.



### 3.3 Cables and wiring length

#### 3.3.1 Cable size

Select the recommended cable size to ensure that a voltage drop will be 2 % max.

If the wiring distance is long between the inverter and motor, a main circuit cable voltage drop will cause the motor torque to decrease especially at the output of a low frequency.

The following table indicates a selection example for the wiring length of 20 m.

#### Single-phase 200 V class (when input power supply is 230 V)

Applicable Inverter Type	Terminal Screw Size *4	Tightening Torque [Nm]	Crimping Terminal	
			L1, N	U, V, W
FR-D720S-008 to 042	M3.5	1.2	2-3.5	2-3.5
FR-D720S-070	M4	1.5	2-4	2-4
FR-D720S-100	M4	1.5	5.5-4	5.5-4

Applicable Inverter Type	Cable Sizes							
	HIV [mm <sup>2</sup> ] *1			AWG *2		PVC [mm <sup>2</sup> ] *3		
	L1, N	U, V, W	Earth Cable Gauge	L1, N	U, V, W	L1, N	U, V, W	Earth Cable Gauge
FR-D720S-008 to 042	2	2	2	14	14	2.5	2.5	2.5
FR-D720S-070	2	2	2	14	14	2.5	2.5	2.5
FR-D720S-100	3.5	2	3.5	12	14	4	2.5	4

#### Three-phase 400 V class (when input power supply is 440 V)

Applicable Inverter Type	Terminal Screw Size *4	Tightening Torque [Nm]	Crimping Terminal	
			R/L1, S/L2, T/L3	U, V, W
FR-D740-012 to 080	M4	1.5	2-4	2-4
FR-D740-120	M4	1.5	2-4	2-4
FR-D740-160	M4	1.5	5.5-4	5.5-4

Applicable Inverter Type	Cable Sizes							
	HIV [mm <sup>2</sup> ] *1			AWG *2		PVC [mm <sup>2</sup> ] *3		
	R/L1, S/L2, T/L3	U, V, W	Earth Cable Gauge	R/L1, S/L2, T/L3	U, V, W	R/L1, S/L2, T/L3	U, V, W	Earth Cable Gauge
FR-D740-012 to 080	2	2	2	14	14	2.5	2.5	2.5
FR-D740-120	3.5	2	3.5	12	14	4	2.5	4
FR-D740-160	3.5	3.5	3.5	12	12	4	4	4

\*1 The recommended cable size is that of the HIV cable (600 V class 2 vinyl-insulated cable) with continuous maximum permissible temperature of 75 °C. Assumes that the ambient temperature is 50 °C or less and the wiring distance is 20 m or less.

\*2 The recommended cable size is that of the THHW cable with continuous maximum permissible temperature of 75 °C. Assumes that the ambient temperature is 40 °C or less and the wiring distance is 20 m or less.  
(Selection example for use mainly in the United States.)

\*3 The recommended cable size is that of the PVC cable with continuous maximum permissible temperature of 70 °C. Assumes that the ambient temperature is 40 °C or less and the wiring distance is 20 m or less.  
(Selection example for use mainly in Europe.)

\*4 The terminal screw size indicates the terminal size for R/L1, S/L2, T/L3, U, V, W, PR, +, -, P1 and a screw for earthing.  
(For single-phase power input, the terminal screw size indicates the size of terminal screw for L1, N, U, V, W, and a screw for earthing (grounding).)

#### NOTE

- Tighten the terminal screw to the specified torque. A screw that has been tightened too loosely can cause a short circuit or malfunction. A screw that has been tightened too tightly can cause a short circuit or malfunction due to the unit breakage.
- Use crimping terminals with insulation sleeve to wire the power supply and motor.

The line voltage drop can be calculated by the following expression:

$$\text{line voltage drop [V]} = \frac{\sqrt{3} \times \text{wire resistance [m}\Omega\text{/m]} \times \text{wiring distance [m]} \times \text{current [A]}}{1000}$$

Use a larger diameter cable when the wiring distance is long or when it is desired to decrease the voltage drop (torque reduction) in the low speed range.

### 3.3.2 Maximum permissible motor wiring length

The maximum permissible length of the motor cables depends on the capacity of the inverter and the selected carrier frequency.

The lengths in the following table are for unshielded cables. When shielded cables are used divide the values listed in the table by 2. Note that the values are for the total wiring length – if you connect more than one motor in parallel you must add the lengths of the individual motor cables.

#### 200 V class

Setting of Pr. 72 PWM Frequency selection (carrier frequency)	008	014	025	042	≥ 070
1 (1 kHz) or less	200 m	200 m	300 m	500 m	500 m
2 to 15 (2 kHz to 14.5 kHz)	30 m	100 m	200 m	300 m	500 m

#### 400 V class

Setting of Pr. 72 PWM Frequency selection (carrier frequency)	012	022	036	050	≥ 080
1 (1 kHz) or less	200 m	200 m	300 m	500 m	500 m
2 to 15 (2 kHz to 14.5 kHz)	30 m	100 m	200 m	300 m	500 m

Total wiring length (FR-D720S-070 or more, FR-D740-080 or more)

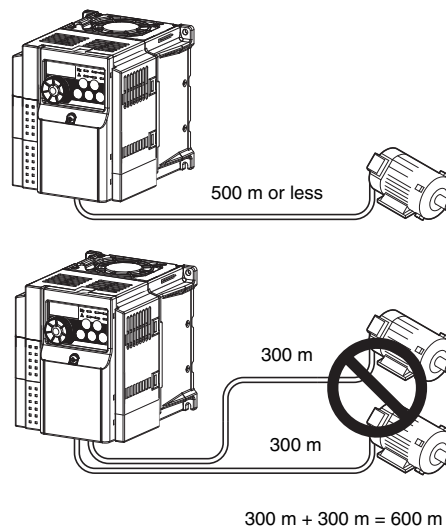

Note that the motor windings in three-phase AC motors are subject to far more stress when operated via frequency inverters than with mains operation. The motor must have been approved by the manufacturer for operation on a frequency inverter.

In the PWM type inverter, a surge voltage attributable to wiring constants is generated at the motor terminals. Especially for a 400 V class motor, the surge voltage may deteriorate the insulation. When the 400 V class motor is driven by the inverter, consider the following measures:

- Use a "400 V class inverter-driven insulation-enhanced motor" and set frequency in Pr. 72 PWM frequency selection according to wiring length.

	≤ 50 m	50 m–100 m	≥ 100 m
Carrier frequency	≤ 14.5 kHz	≤ 8 kHz	≤ 2 kHz

- Limiting the voltage rise speed of the frequency inverter output voltage (dU/dT):  
If the motor requires a rise speed of 500 V/μs or less you must install a filter in the output of the inverter. Please contact your Mitsubishi dealer for more details.

#### CAUTION

- Especially for long-distance wiring (particularly when employing shielded motor cables), the inverter may be affected by a charging current caused by the stray capacitances of the wiring, leading to a malfunction of the overcurrent protective function or fast response current limit function, or stall prevention function or a malfunction or fault of the equipment connected on the inverter output side. When the fast-response current limit function malfunctions, make the function invalid. When stall prevention function misoperates, increase the stall level. (For Pr. 22 Stall prevention operation level and Pr. 156 Stall prevention operation selection, refer to the Instruction Manual.)
- For details of Pr. 72 PWM frequency selection, refer to the Instruction Manual.
- When using the automatic restart after instantaneous power failure function with wiring length exceeding below, select without frequency search (Pr. 162 = „1“, „11“).(Refer to the instruction manual for further information to Pr. 162).

Motor capacity	0.1 K	0.2 K	0.4 K
Wiring length	20 m	50 m	100 m



### 3.4 Control circuit specification

#### 3.4.1 Standard control circuit terminal layout

Recommended cable size:  
0.3 mm<sup>2</sup> to 0.75 mm<sup>2</sup>

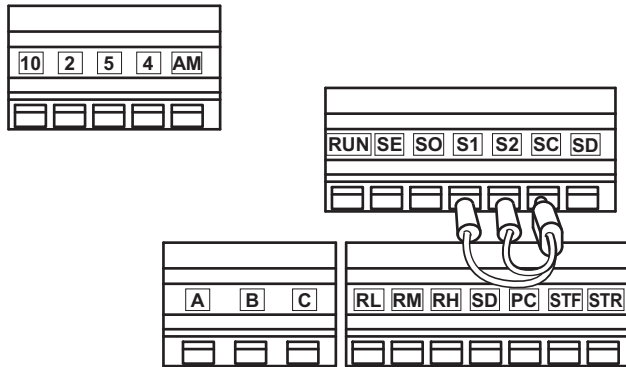

#### 3.4.2 Wiring method

##### Wiring

Use a bar terminal and a cable with a sheath stripped off for the control circuit wiring. For a single wire, strip off the sheath of the cable and apply directly. Insert the bar terminal or the single wire into a socket of the terminal.

- Strip off the sheath about the size below. If the length of the sheath peeled is too long, a short circuit may occur among neighboring wires. If the length is too short, wires might come off.

Wire the stripped cable after twisting it to prevent it from becoming loose. In addition, do not solder it.

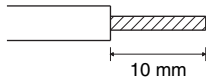

- Crimp the bar terminal. Insert wires to a bar terminal, and check that the wires come out for about 0 to 0.5 mm from a sleeve.

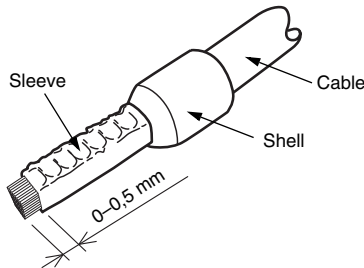

- Check the condition of the bar terminal after crimping. Do not use a bar terminal of which the crimping is inappropriate, or the face is damaged.

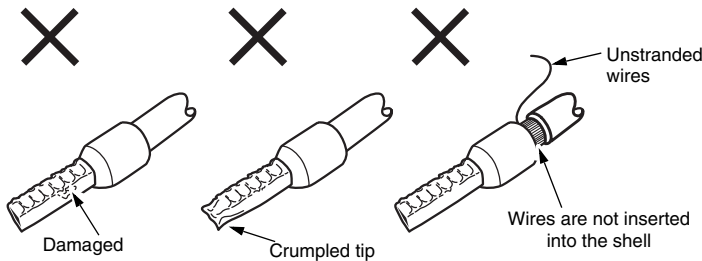

Introduced products on bar terminals:

Wire Size [mm <sup>2</sup> ]	Bar Terminal Model		Maker
	With Insulation Sleeve	Without Insulation Sleeve	
0.3/0.5	AI 0.5-10WH	—	Phoenix Contact Co., Ltd.
0.75	AI 0.75-10GY	A 0.75-10	
1	AI 1-10RD	A 1-10	
1.25/1.5	AI 1.5-10BK	A 1.5-10	
0.75 (for two cables)	AI-TWIN 2 × 0.75-10GY	—	

Bar terminal crimping tool: CRIMPFOX ZA3 (Phoenix Contact Co., Ltd.)

- Insert the wire into a socket.

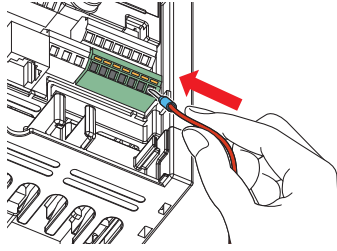

When using a stranded wire without a bar terminal, push an open/close button all the way down with a flathead screwdriver, and insert the wire.

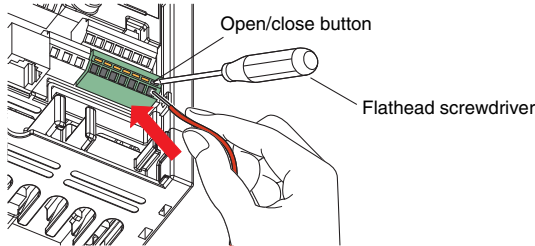

### CAUTION

- When using a stranded wire without a bar terminal, twist enough to avoid short circuit with nearby terminals or wires.
- Place the flathead screwdriver vertical to the open/close button. In case the blade tip slips, it may cause damage to the inverter or injury.

### Wire removal

- Pull the wire by pushing the open/close button all the way down firmly with a flathead screwdriver.

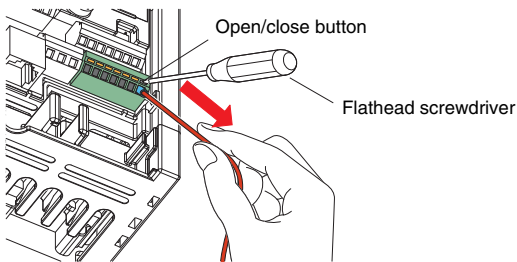

### CAUTION

- Use a small flathead screwdriver (Tip thickness: 0.4mm/tip width: 2.5mm). If a flathead screwdriver with a narrow tip is used, the terminal block may be damaged.
- Place the flathead screwdriver vertical to the open/close button. In case the blade tip slips, it may cause damage to the inverter or injury.

## 3.4.3 Wiring instructions

- Terminals PC, 5, and SE are all common terminals (0 V) for I/O signals and are isolated from each other. Avoid connecting the terminal PC and 5 and the terminal SE and 5 (ground). Terminal PC is a common terminal for the contact input terminals (STF, STR, RH, RM, RL).
- Use shielded or twisted cables for connection to the control circuit terminals and run them away from the main and power circuits (including the 230 V relay sequence circuit).
- Use two or more parallel micro-signal contacts or twin contacts to prevent contact faults when using contact inputs since the control circuit input signals are micro-currents.
- Do not apply a voltage to the contact input terminals (e.g. STF) of the control circuit.
- Always apply a voltage to the alarm output terminals (A, B, C) via a relay coil, lamp, etc.
- It is recommended to use cables of 0.3 mm<sup>2</sup> to 0.75 mm<sup>2</sup> gauge for connection to the control circuit terminals. If the cable gauge used is 1.25 mm<sup>2</sup> or more, the front cover may not be mounted correctly. Run the cables in a proper way in order to mount the front cover correctly.
- The wiring length should be 30 m maximum.
- The level of the control signals can be switched over between positive (SOURCE) and negative (SINK) logic. The input signals are set to source logic when shipped from the factory. To change the control logic, the jumper connector above the control circuit terminal block must be moved to the other position.

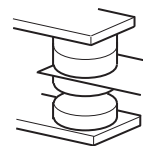

Micro signal contacts

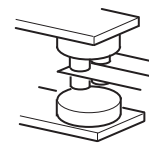

Twin contacts

---

---

## 4 PRECAUTIONS FOR USE OF THE INVERTER

---

---

The FR-D700 series is a highly reliable product, but incorrect peripheral circuit making or operation/handling method may shorten the product life or damage the product.

Before starting operation, always recheck the following items.

- Use crimping terminals with insulation sleeve to wire the power supply and motor.
- Application of power to the output terminals (U, V, W) of the inverter will damage the inverter. Never perform such wiring.
- After wiring, wire offcuts must not be left in the inverter.  
Wire offcuts can cause an alarm, failure or malfunction. Always keep the inverter clean. When drilling mounting holes in a control box etc., take care not to allow chips and other foreign matter to enter the inverter.
- Use cables of the size to make a voltage drop 2 % maximum.  
If the wiring distance is long between the inverter and motor, a main circuit cable voltage drop will cause the motor torque to decrease especially at the output of a low frequency.  
Refer to *page 6* for the recommended cable size.
- The overall wiring length should be 500 m maximum.  
Especially for long distance wiring, the fast-response current limit function may be reduced or the equipment connected to the inverter output side may malfunction or become faulty under the influence of a charging current due to the stray capacity of the wiring. Therefore, note the overall wiring length. (Refer to *page 7*)
- Electromagnetic Compatibility  
Operation of the frequency inverter can cause electromagnetic interference in the input and output that can be propagated by cable (via the power input lines), by wireless radiation to nearby equipment (e.g. AM radios) or via data and signal lines. Install an optional filter if present to reduce air propagated interference on the input side of the inverter. Use AC or DC reactors to reduce line propagated noise (harmonics). Use shielded motor power lines to reduce output noise.
- Do not install a power factor correction capacitor, varistor or arrester on the inverter output side. This will cause the inverter to trip or the capacitor, varistor, or arrester to be damaged. If any of the above devices is installed, immediately remove it.
- Before starting wiring or other work after the inverter is operated, wait for at least 10 minutes after the power supply has been switched off, and check that there are no residual voltage using a tester or the like. The capacitor is charged with high voltage for some time after power off and it is dangerous.
- A short circuit or earth fault on the inverter output side may damage the inverter modules.
  - Fully check the insulation resistance of the circuit prior to inverter operation since repeated short circuits caused by peripheral circuit inadequacy or an earth fault caused by wiring inadequacy or reduced motor insulation resistance may damage the inverter modules.
  - Fully check the to-earth insulation and inter-phase insulation of the inverter output side before power-on.  
Especially for an old motor or use in hostile atmosphere, securely check the motor insulation resistance etc.
- Do not use the inverter input side magnetic contactor to start/stop the inverter.  
Always use the start signal (ON/OFF of STF and STR signals) to start/stop the inverter.
- Across + and PR terminals, connect only an external regenerative brake discharge resistor. Do not connect a mechanical brake.  
The brake resistor can not be connected to the FR-D720S-008 and 014. Leave terminals + and PR open.  
Also, never short between + and PR.

- Do not apply a voltage higher than the permissible voltage to the inverter I/O signal circuits.  
Application of a voltage higher than the permissible voltage to the inverter I/O signal circuits or opposite polarity may damage the I/O devices. Especially check the wiring to prevent the speed setting potentiometer from being connected incorrectly to short terminals 10-5.
- Provide electrical and mechanical interlocks for MC1 and MC2 which are used for bypass operation.  
When the wiring is incorrect or if there is a bypass circuit as shown below, the inverter will be damaged by leakage current from the power supply due to arcs generated at the time of switch-over or chattering caused by a sequence error.
- If the machine must not be restarted when power is restored after a power failure, provide a magnetic contactor in the inverter's input side and also make up a sequence which will not switch on the start signal.  
If the start signal (start switch) remains on after a power failure, the inverter will automatically restart as soon as the power is restored.
- Instructions for overload operation  
When performing operation of frequent start/stop of the inverter, increase/decrease in the temperature of the transistor element of the inverter may repeat due to a continuous flow of large current, shortening the life from thermal fatigue. Since thermal fatigue is related to the amount of current, the life can be increased by reducing bound current, starting current, etc. Decreasing current may increase the life. However, decreasing current will result in insufficient torque and the inverter may not start. Therefore, increase the inverter capacity to have enough allowance for current.
- Make sure that the specifications and rating match the system requirements.
- When the motor speed is unstable, due to change in the frequency setting signal caused by electromagnetic noises from the inverter, take the following measures when applying the motor speed by the analog signal.
  - Do not run the signal cables and power cables (inverter I/O cables) in parallel with each other and do not bundle them.
  - Run signal cables as far away as possible from power cables (inverter I/O cables).
  - Use shielded cables as signal cables.
  - Install a ferrite core on the signal cable (Example: ZCAT3035-1330 TDK).

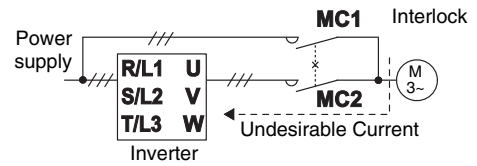

# 5 FAILSAFE OF THE SYSTEM WHICH USES THE INVERTER

When a fault occurs, the inverter trips to output a fault signal. However, a fault output signal may not be output at an inverter fault occurrence when the detection circuit or output circuit fails, etc. Although Mitsubishi assures best quality products, provide an interlock which uses inverter status output signals to prevent accidents such as damage to machine when the inverter fails for some reason and at the same time consider the system configuration where failsafe from outside the inverter, without using the inverter, is enabled even if the inverter fails.

### Interlock method which uses the inverter status output signals

By combining the inverter status output signals to provide an interlock as shown below, an inverter alarm can be detected.

Interlock Method	Check Method	Used Signals	Refer to Page
Inverter protective function operation	Operation check of an alarm contact Circuit error detection by negative logic	Fault output signal (ALM signal)	Refer to chapter Parameter of the Instruction Manual
Inverter running status	Operation ready signal check	Operation ready signal (RY signal)	
	Logic check of the start signal and running signal	Start signal (STF signal, STR signal) Running signal (RUN signal)	
	Logic check of the start signal and output current	Start signal (STF signal, STR signal) Output current detection signal (Y12 signal)	

### Backup method outside the inverter

Even if the interlock is provided by the inverter status signal, enough failsafe is not ensured depending on the failure status of the inverter itself. For example, even if the interlock is provided using the inverter fault output signal, start signal and RUN signal output, there is a case where a fault output signal is not output and RUN signal is kept output even if an inverter fault occurs.

Provide a speed detector to detect the motor speed and current detector to detect the motor current and consider the backup system such as checking up as below according to the level of importance of the system. Check the motor running and motor current while the start signal is input to the inverter by comparing the start signal to the inverter and detected speed of the speed detector or detected current of the current detector. Note that the motor current runs as the motor is running for the period until the motor stops since the inverter starts decelerating even if the start signal turns off. For the logic check, configure a sequence considering the inverter deceleration time. In addition, it is recommended to check the three-phase current when using the current detector.

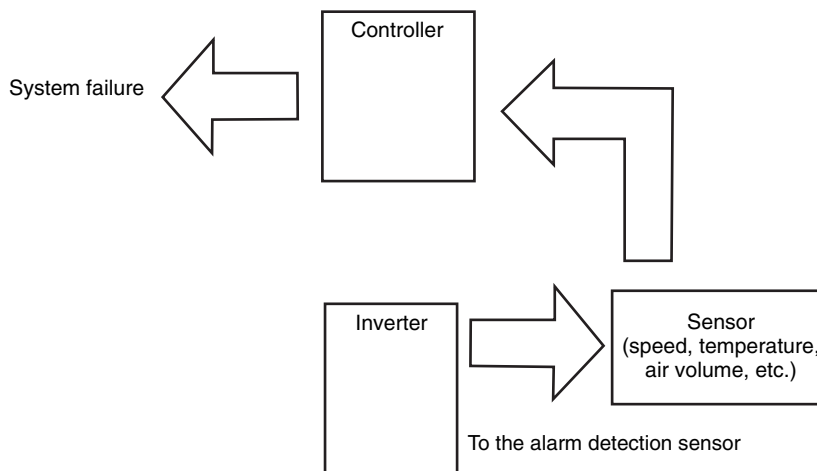

Check if there is no gap between the actual speed and commanded speed by comparing the inverter speed command and detected speed of the speed detector.

## 6 PARAMETER

For simple variable-speed operation of the inverter, the initial setting of the parameters may be used as they are. Set the necessary parameters to meet the load and operational specifications. Parameter setting, change and check can be made from the operation panel. For details of parameters, refer to the instruction manual.

In the initial setting, only the simple mode parameters are displayed.

Set Pr. 160 *Extended function display selection* as required.

Parameter	Name	Initial Value	Setting Range	Remarks
160	Extended function display selection	9999	9999	Only the simple mode parameters can be displayed.
			0	Simple mode and extended mode parameters can be displayed.

### Remarks

- The parameters marked © are the simple mode parameters.
- The parameters marked with  in the table allow its setting to be changed during operation even if "0" (initial value) is set in Pr. 77 *Parameter write selection*.

Parameter	Name	Setting Range	Initial Value
© 0	Torque boost	0 to 30 %	6/4/3 * <sup>1</sup>
© 1	Maximum frequency	0 to 120 Hz	120 Hz
© 2	Minimum frequency	0 to 120 Hz	0 Hz
© 3	Base frequency	0 to 400 Hz	50 Hz
© 4	Multi-speed setting (high speed)	0 to 400 Hz	50 Hz
© 5	Multi-speed setting (middle speed)	0 to 400 Hz	30 Hz
© 6	Multi-speed setting (low speed)	0 to 400 Hz	10 Hz
© 7	Acceleration time	0 to 3600 s	5 s/10 s * <sup>2</sup>
© 8	Deceleration time	0 to 3600 s	5 s/10 s * <sup>2</sup>
© 9	Electronic thermal O/L relay	0 to 500 A	Rated inverter output current
10	DC injection brake operation frequency	0 to 120 Hz	3 Hz
11	DC injection brake operation time	0 to 10 s	0.5 s
12	DC injection brake operation voltage	0 to 30 %	6/4 % * <sup>3</sup>
13	Starting frequency	0 to 60 Hz	0.5 Hz
14	Load pattern selection	0 to 3	0
15	Jog frequency	0 to 400 Hz	5 Hz
16	Jog acceleration/ deceleration time	0 to 3600 s	0.5 s

Parameter	Name	Setting Range	Initial Value
17	MRS input selection	0, 2, 4	0
18	High speed maximum frequency	120 to 400 Hz	120 Hz
19	Base frequency voltage	0 to 1000 V, 8888, 9999	8888
20	Acceleration/ deceleration reference frequency	1 to 400 Hz	50 Hz
22	Stall prevention operation level	0 to 200 %	150 %
23	Stall prevention operation level compensation factor at double speed	0 to 200 %, 9999	9999
24 to 27	Multi-speed setting 4 speed to 7 speed	0 to 400 Hz, 9999	9999
29	Acceleration/ deceleration pattern selection	0, 1, 2	0
30	Regenerative function selection	0, 1, 2	0
31	Frequency jump 1A	0 to 400 Hz, 9999	9999
32	Frequency jump 1B		9999
33	Frequency jump 2A		9999
34	Frequency jump 2B		9999
35	Frequency jump 3A		9999
36	Frequency jump 3B		9999
37	Speed display	0, 0.01 to 9998	0
40	RUN key rotation direction selection	0, 1	0
41	Up-to-frequency sensitivity	0 to 100 %	10 %

\*<sup>1</sup> Differ according to capacities.

6 %: FR-D720S-042 or less, FR-D740-022 or less  
4 %: FR-D720S-070 and 100, FR-D740-036 to 080  
3 %: FR-D740-120 and 160

\*<sup>2</sup> Differ according to capacities.

5 s: FR-D720S-008 to 100, FR-D740-080 or less  
10 s: FR-D740-120 and 160

\*<sup>3</sup> Differ according to capacities.

6 %: FR-D720S-008 and 014  
4 %: FR-D720S-025 and 100, FR-D740-012 to 160



Parameter	Name	Setting Range	Initial Value
42	Output frequency detection	0 to 400 Hz	6 Hz
43	Output frequency detection for reverse rotation	0 to 400 Hz, 9999	9999
44	Second acceleration/ deceleration time	0 to 3600 s	5 s/10 <sup>*1</sup>
45	Second deceleration time	0 to 3600, 9999	9999
46	Second torque boost	0 to 30 %, 9999	9999
47	Second V/F (base frequency)	0 to 400 Hz, 9999	9999
48	Second stall prevention operation current	0 to 200 %, 9999	9999
51	Second electronic thermal O/L relay	0 to 500 A, 9999	9999
52	DU/PU main display data selection	0, 5, 8 to 12, 14, 20, 23 to 25, 52 to 55, 61, 62, 64, 100	0
55	Frequency monitoring reference	0 to 400 Hz	50 Hz
56	Current monitoring reference	0 to 500 A	Rated inverter output current
57	Restart coasting time	0, 0.1 to 5 s, 9999	9999
58	Restart cushion time	0 to 60 s	1 s
59	Remote function selection	0, 1, 2, 3	0
60	Energy saving control selection	0, 9	0
65	Retry selection	0 to 5	0
66	Stall prevention operation reduction starting frequency	0 to 400 Hz	50 Hz
67	Number of retries at alarm occurrence	0 to 10, 101 to 110	0
68	Retry waiting time	0.1 to 600s	1s
69	Retry count display erase	0	0
70	Special regenerative brake duty	0 to 30 %	0 %
71	Applied motor	0, 1, 3, 13, 23, 40, 43, 50, 53	0
72	PWM frequency selection	0 to 15	1
73	Analog input selection	0, 1, 10, 11	1
74	Input filter time constant	0 to 8	1
75	Reset selection/ disconnected PU detection/PU stop selection	0 to 3, 14 to 17	14

Parameter	Name	Setting Range	Initial Value
77	Parameter write selection	0, 1, 2	0
78	Reverse rotation prevention selection	0, 1, 2	0
Ⓢ 79	Operation mode selection	0, 1, 2, 3, 4, 6, 7	0
80	Motor capacity	0.1 to 7.5 kW, 9999	9999
82	Motor excitation current	0 to 500 A, 9999	9999
83	Motor rated voltage	0 to 1000 V	200 V/ 400 V <sup>*2</sup>
84	Rated motor frequency	10 to 120 Hz	50 Hz
90	Motor constant (R1)	0 to 50 Ω, 9999	9999
96	Auto tuning setting status	0, 11, 21	0
117	PU communication station number	0 to 31 (0 to 247)	0
118	PU communication speed	48, 96, 192, 384	192
119	PU communication stop bit length	0, 1, 10, 11	1
120	PU communication parity check	0, 1, 2	2
121	Number of PU communication retries	0 to 10, 9999	1
122	PU communication check time interval	0, 0.1 to 999.8 s, 9999	0
123	PU communication waiting time setting	0 to 150 ms, 9999	9999
124	PU communication CR/LF presence/ absence selection	0, 1, 2	1
Ⓢ 125	Terminal 2 frequency setting gain frequency	0 to 400 Hz	50 Hz
Ⓢ 126	Terminal 4 frequency setting gain frequency	0 to 400 Hz	50 Hz
127	PID control automatic switchover frequency	0 to 400 Hz, 9999	9999
128	PID action selection	0, 20, 21, 40 to 43	0
129	PID proportional band	0.1 to 1000 %, 9999	100 %
130	PID integral time	0.1 to 3600 s, 9999	1 s
131	PID upper limit	0 to 100 %, 9999	9999
132	PID lower limit	0 to 100 %, 9999	9999
133	PID action set point	0 to 100 %, 9999	9999
134	PID differential time	0.01 to 10.00 s, 9999	9999
145	PU display language selection	0 to 7	1

<sup>\*1</sup> Differ according to capacities.  
5 s: FR-D720S-008 to 100, FR-D740-080 or less  
10 s: FR-D740-120 and 160

<sup>\*2</sup> The initial value differs according to the voltage class:  
200 V/400 V

Parameter	Name	Setting Range	Initial Value
146	Parameter for manufacturer setting. Do not set.		
150	Output current detection level	0 to 200 %	150 %
151	Output current detection signal delay time	0 to 10 s	0 s
152	Zero current detection level	0 to 200 %	5 %
153	Zero current detection time	0 to 1 s	0.5 s
156	Stall prevention operation selection	0 to 31, 100, 101	0
157	OL signal output timer	0 to 25 s, 9999	0 s
158	AM terminal function selection	1 to 3, 5, 8 to 12, 14, 21, 24, 52, 53, 61, 62	1
©160	Extended function display selection	0, 9999	9999
161	Frequency setting/ key lock operation selection	0, 1, 10, 11	0
162	Automatic restart after instantaneous power failure selection	0, 1, 10, 11	1
165	Stall prevention operation level for restart	0 to 200 %	150 %
166	Output current detection signal retention time	0 to 10 s, 9999	0.1 s
167	Output current detection operation selection	0, 1	0
168	Parameter for manufacturer setting. Do not set.		
169	Do not set.		
170	Watt-hour meter clear	0, 10, 9999	9999
171	Operation hour meter clear	0, 9999	9999
178	STF terminal function selection	0 to 5, 7, 8, 10, 12, 14, 16, 18, 24, 25, 37, 60, 62, 65 to 67, 9999	60
179	STR terminal function selection	0 to 5, 7, 8, 10, 12, 14, 16, 18, 24, 25, 37, 61, 62, 65 to 67, 9999	61
180	RL terminal function selection	0 to 5, 7, 8, 10, 12, 14, 16, 18, 24, 25, 37, 62, 65 to 67, 9999	0
181	RM terminal function selection		1
182	RH terminal function selection		2
190	RUN terminal function selection	0, 1, 3, 4, 7, 8, 11 to 16, 25, 26, 46, 47, 64, 70, 90, 91, 93, 95, 96, 98, 99, 100, 101, 103, 104, 107, 108, 111 to 116, 125, 126, 146, 147, 164, 170, 190, 191, 193, 195, 196, 198, 199, 9999	0

Parameter	Name	Setting Range	Initial Value
192	ABC terminal function selection	0, 1, 3, 4, 7, 8, 11 to 16, 25, 26, 46, 47, 64, 70, 90, 91, 95, 96, 98, 99, 100, 101, 103, 104, 107, 108, 111 to 116, 125, 126, 146, 147, 164, 170, 190, 191, 195, 196, 198, 199, 9999	99
232 to 239	Multi-speed setting (speeds 8 to 15)	0 to 400 Hz, 9999	9999
240	Soft-PWM operation selection	0, 1	1
241	Analog input display unit switchover	0, 1	0
244	Cooling fan operation selection	0, 1	1
245	Rated slip	0 to 50 %, 9999	9999
246	Slip compensation time constant	0.01 to 10 s	0.5 s
247	Constant-power range slip compensation selection	0, 9999	9999
249	Earth (ground) fault detection at start	0, 1	0
250	Stop selection	0 to 100 s, 1000 to 1100 s, 8888, 9999	9999
251	Output phase loss protection selection	0, 1	1
255	Life alarm status display	(0 to 15)	0
256	Inrush current suppression circuit life display	(0 to 100 %)	100 %
257	Control circuit capacitor life display	(0 to 100 %)	100 %
258	Main circuit capacitor life display	(0 to 100 %)	100 %
259	Main circuit capacitor life measuring	0, 1 (2, 3, 8, 9)	0
260	PWM frequency automatic switchover	0, 1	0
261	Power failure stop selection	0, 1, 2	0
267	Terminal 4 input selection	0, 1, 2	0
268	Monitor decimal digits selection	0, 1, 9999	9999
269	Parameter for manufacturer setting. Do not set.		
295	Magnitude of frequency change setting	0, 0.01, 0.10, 1.00, 10.00	0
296	Password lock level	1 to 6, 101 to 106, 9999	9999
297	Password lock/ unlock	1000 to 9998 (0 to 5, 9999)	9999
298	Frequency search gain	0 to 32767, 9999	9999
299	Rotation direction detection selection at restarting	0, 1, 9999	0
338	Communication operation command source	0, 1	0
339	Communication speed command source	0, 1, 2	0



Parameter	Name	Setting Range	Initial Value
340	Communication startup mode selection	0, 1, 10	0
342	Communication EEPROM write selection	0, 1	0
343	Communication error count	—	0
450	Second applied motor	0, 1, 9999	9999
495	Remote output selection	0, 1, 10, 11	0
496	Remote output data 1	0 to 4095	0
502	Stop mode selection at communication error	0,1, 2	0
503	Maintenance timer	0 (1 to 9998)	0
504	Maintenance timer alarm output set time	0 to 9998, 9999	9999
549	Protocol selection	0, 1	0
551	PU mode operation command source selection	2, 4, 9999	2
555	Current average time	0.1 to 1 s	1 s
556	Data output mask time	0.0 to 20 s	0 s
557	Current average value monitor signal output reference current	0 to 500 A	Rated inverter current
561	PTC thermistor protection level	0.5 to 30 Ω, 9999	9999
563	Energization time carrying-over times	(0 to 65535)	0
564	Operating time carrying-over times	(0 to 65535)	0
571	Holding time at a start	0.0 to 10.0 s, 9999	9999
575	Output interruption detection time	0 to 3600 s, 9999	1 s
576	Output interruption detection level	0 to 400 Hz	0 Hz
577	Output interruption cancel level	900 to 1100 %	1000 %
592	Traverse function selection	0, 1, 2	0
593	Maximum amplitude amount	0 to 25 %	10 %
594	Amplitude compensation amount during deceleration	0 to 50 %	10 %
595	Amplitude compensation amount during acceleration	0 to 50 %	10 %
596	Amplitude acceleration time	0.1 to 3600 s	5 s
597	Amplitude deceleration time	0.1 to 3600 s	5 s
611	Acceleration time at a restart	0 to 3600 s, 9999	9999

Parameter	Name	Setting Range	Initial Value
653	Speed smoothing control	0 to 200 %	0
665	Regeneration avoidance frequency gain	0 to 200 %	100
872 *1	Input phase loss protection selection	0, 1	1
882	Regeneration avoidance operation selection	0, 1, 2	0
883	Regeneration avoidance operation level	300 to 800 V	400 V / 780 V DC *2
885	Regeneration avoidance compensation frequency limit value	0 to 10 Hz, 9999	6 Hz
886	Regeneration avoidance voltage gain	0 to 200 %	100 %
888	Free parameter 1	0 to 9999	9999
889	Free parameter 2	0 to 9999	9999
891	Cumulative power monitor digit shifted times	0 to 4, 9999	9999
C1 (901) *3	AM terminal calibration	—	—
C2 (902) *3	Terminal 2 frequency setting bias frequency	0 to 400 Hz	0 Hz
C3 (902) *3	Terminal 2 frequency setting bias	0 to 300 %	0 %
125 (903) *3	Terminal 2 frequency setting gain frequency	0 to 400 Hz	50 Hz
C4 (903) *3	Terminal 2 frequency setting gain	0 to 300 %	100 %
C5 (904) *3	Terminal 4 frequency setting bias frequency	0 to 400 Hz	0 Hz
C6 (904) *3	Terminal 4 frequency setting bias	0 to 300 %	20 %
126 (905) *3	Terminal 4 frequency setting gain frequency	0 to 400 Hz	50 Hz
C7 (905) *3	Terminal 4 frequency setting gain	0 to 300 %	100 %

\*1 Available only for the three-phase power input specification model.

\*2 The initial value differs according to the voltage class:  
200 V/400 V

\*3 The parameter number in parentheses is the one for use with the operation panel (FR-PA02-02) for the FR-E500 series or parameter unit (FR-PU04/FR-PU07).

Parameter	Name	Setting Range	Initial Value
<b>C22</b> (922) *1	Parameter for manufacturer setting. Do not set.		
<b>C23</b> (922) *1			
<b>C24</b> (923) *1			
<b>C25</b> (923) *1			
<b>990</b>	<b>PU buzzer control</b>	0, 1	1
<b>991</b>	<b>PU contrast adjustment</b>	0 to 63	58
<b>Pr.CL</b>	<b>Parameter clear</b>	0, 1	0
<b>ALLC</b>	<b>All parameter clear</b>	0, 1	0
<b>Er.CL</b>	<b>Alarm history clear</b>	0, 1	0
<b>Pr.CH</b>	<b>Initial value change list</b>	—	—

\*1 The parameter number in parentheses is the one for use with the operation panel (FR-PA02-02) for the FR-E500 series or parameter unit (FR-PU04/FR-PU07).

# 7 TROUBLESHOOTING

When a fault occurs in the inverter, the protective function is activated bringing the inverter to an alarm stop and the PU display automatically changes to any of the following fault (alarm) indications.

If the fault does not correspond to any of the following faults or if you have any other problem, please contact your sales representative.

- Retention of fault output signal..... When the magnetic contactor (MC) provided on the input side of the inverter is opened at the activation of the protective function, the inverter's control power will be lost and the alarm output will not be held.
- Fault or alarm display..... When a fault or alarm occurs, the operation panel display automatically switches to the fault or alarm indication.
- Resetting method ..... When a protective function of the inverter is activated, the power output of the inverter is blocked (motor is coasting). The inverter cannot start up again unless an automatic restart has been configured or the inverter is reset. Please observe carefully the warnings contained below in the configuration of an automatic restart or the execution of a reset.
- If protective functions were activated (i. e. the inverter switched off with an error message) follow the instructions for error correction provided in the manual for the inverter. Especially in the case of short circuits or earth contacts in the inverter output and mains overvoltages the cause of the fault must be determined prior to switching on again as a recurrence of such faults at short intervals can lead to premature aging of components or even the complete breakdown of the device. After the cause of the fault has been found and corrected the inverter can be reset and operations continue.

Inverter fault or alarm indications are roughly divided as below.

- Error Message  
A message regarding operational fault and setting fault by the operation panel and parameter unit (FR-PU04/FR-PU07) is displayed. The inverter does not shut off output.
- Warnings  
The inverter does not shut off output even when a warning is displayed. However, failure to take appropriate measures will lead to a major fault.
- Alarm  
The inverter does not shut off output. You can also output an alarm signal by making parameter setting.
- Fault  
When the protective function is activated, the inverter output is shut off and an fault signal is output.

## 7.1 Reset method of protective function

### Resetting the inverter

The inverter can be reset by performing any of the following operations. Note that the internal thermal integrated value of the electronic thermal relay function and the number of retries are cleared (erased) by resetting the inverter. Recover about 1 s after reset is cancelled.

Three different methods can be used to reset an inverter.

- Using the operation panel, press the STOP/RESET key to reset the inverter.  
(This may only be performed when a fault occurs.)

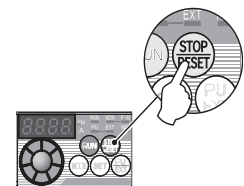

- Switch power off once, then switch it on again.

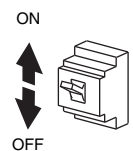

- Turn on the reset signal (RES) for more than 0.1 s. (If the RES signal is kept on, "Err." appears (flickers) to indicate that the inverter is in a reset status.)

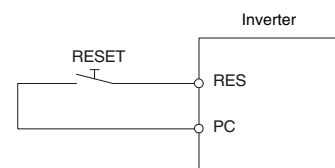

## 7.2 List of alarm display

Operation Panel Indication		Meaning
Error messages	E---	E--- Faults history
	HOLD	HOLD Operation panel lock
	Er1 to Er4	Er1 to 4 Parameter write error
	Err.	Err. Inverter reset
	LOCd	LOCd Password locked
Warnings	OL	OL Stall Prevention (overcurrent)
	oL	oL Stall prevention (overvoltage)
	rb	RB Regenerative brake prealarm
	TH	TH Electronic thermal relay function prealarm
	PS	PS PU Stop
	MT	MT Maintenance signal output
	UV	UV Undervoltage
Alarm	Fn	FN Fan alarm
Fault	E.OC1	E.OC1 Overcurrent shut-off during acceleration
	E.OC2	E.OC2 Overcurrent shut-off during constant speed
	E.OC3	E.OC3 Overcurrent shut-off during deceleration or stop
	E.OV1	E.OV1 Regenerative overvoltage shut-off during acceleration
	E.OV2	E.OV2 Regenerative overvoltage shut-off during constant speed
	E.OV3	E.OV3 Regenerative overvoltage shut-off during deceleration or stop
	E.THT	E.THT Inverter overload shut-off (electronic thermal relay function)
	E.THM	E.THM Motor overload shut-off (electronic thermal relay function)
	E.FIN	E.FIN Fin overheat

Operation Panel Indication		Meaning
Fault	E.ILF	E.ILF* Input phase loss
	E.OLT	E.OLT Stall prevention
	E.bE	E.BE Brake transistor alarm detection
	E.GF	E.GF Output side earth (ground) fault overcurrent protection
	E.LF	E.LF Output phase loss
	E.OHT	E.OHT External thermal relay operation
	E.PTC	E.PTC* PTC thermistor operation
	E.PE	E.PE Parameter storage device fault
	E.PUE	E.PUE PU disconnection
	E.RET	E.RET Retry count excess
	E.CPU	E.CPU CPU fault
	E.CDO	E.CDO* Output current detection value exceeded
	E.IOH	E.IOH* Inrush current limit circuit fault
	E.AIE	E.AIE* Analog input fault

\* If an E.ILF, E.PTC, E.CDO, E.IOH or E.AIE fault occurs when using the FR-PU04, "Fault 14" is displayed on the FR-PU04.

---

---

# A APPENDIX

---

---

## A.1 Instructions for Compliance with the European Directives

---

### A.1.1 EMC Directive

- Our view of transistorized inverters for the EMC Directive  
A transistorized inverter is a component designed for installation in an enclosure and for use with the other equipment to control the equipment/device. Therefore, we understand that the EMC Directive does not apply directly to transistorized inverters. For this reason, we do not place the CE mark on the transistorized inverters. (The CE mark is placed on inverters in accordance with the Low Voltage Directive.) CEMEP
- Compliance  
We understand that the general-purpose inverters are not covered directly by the EMC Directive. However, the EMC Directive applies to machines/equipment into which inverters have been incorporated, and these machines and equipment must carry the CE marks. EMC Installation Guidelines BCN-A21041-202
- Outline of installation method  
Install an inverter using the following methods:
  - Use the inverter with an European Standard-compliant noise filter.
  - For wiring between the inverter and motor, use shielded cables or run them in a metal piping and ground the cables on the inverter and motor sides with the shortest possible distance.
  - Insert a line noise filter and ferrite core into the power and control lines as required.  
Full information including the European Standard-compliant noise filter specifications are written in the technical information "EMC Installation Guidelines" (BCN-A21041-202). Please contact your sales representative.

### A.1.2 Low Voltage Directive

We have self-confirmed our inverters as products compliant to the Low Voltage Directive (Conforming standard EN 61800-5-1) and placed the CE mark on the inverters.

#### Outline of instructions

- If your application require by installation standards a RCD (residual current device) as up stream protection please select according to DIN VDE 0100-530 as following:  
Single phase inverter type A or B  
Three phase inverter only type B
  - Additionally, when selecting a residual current device (RCD), leakage current caused by the mains filter, the length of the shielded motor cable and the carrier frequency must be taken into consideration.
  - When connecting AC current using switches without a step function, brief asymmetrical loads may result in unwanted triggering of the residual current device (RCD). It is recommendable here to use a Type B residual current device (RCD) Type B with delayed actuation or to switch on all three phases simultaneously using a main contactor.
- If you don't use a RCD, provide double or reinforced insulation between the inverter and other equipment, or put a transformer between the main power supply and inverter.
- Do not use a RCD as an electric shock protector without connecting the equipment to the earth. Connect the equipment to the earth securely.
- Wire the earth terminal independently. (Do not connect two or more cables to one terminal.)
- Use the cable sizes on *page 6* under the following conditions.
  - Ambient temperature: 40 °C maximum  
If conditions are different from above, select appropriate wire according to EN60204 ANNEX C TABLE 5.
- When tightening the screw, be careful not to damage the threads.
- For use as a product compliant with the Low Voltage Directive, use PVC cable whose size is indicated on *page 6*.
- Use the moulded case circuit breaker and magnetic contactor which conform to the EN or IEC Standard.
- Use the inverter under the conditions of overvoltage category II (usable regardless of the earth (ground) condition of the power supply), overvoltage category III (usable with the earthed-neutral system power supply, 400 V class only) specified in IEC664.
- To use the inverter under the conditions of pollution degree 3, install it in the enclosure of IP54 or higher.

- To use the inverter (IP20) outside of an enclosure in the environment of pollution degree 2, fix a fan cover with the fan cover fixing screws enclosed.

FR-D720S-070 and 100, FR-D740-080 or less

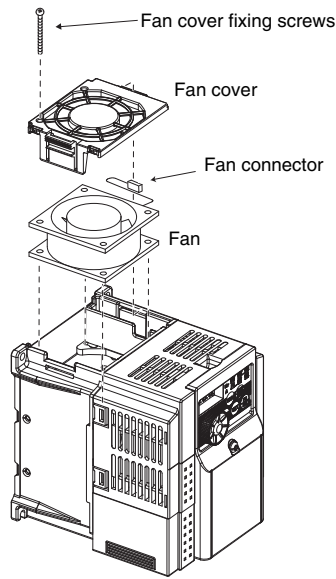

Example for FR-D740-036

FR-D740-120 or more

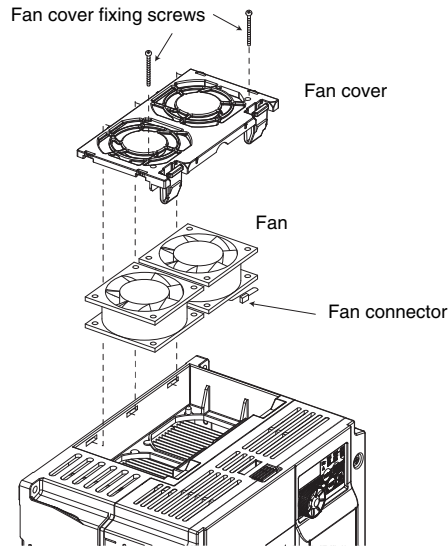

Example for FR-D740-160

- On the input and output of the inverter, use cables of the type and size set forth in EN60204 Appendix C.
- The operating capacity of the relay outputs (terminal symbols A, B, C) should be 30 V DC, 0.3 A. (Relay outputs are basically isolated from the inverter internal circuit.)
- Control circuit terminals on page 4 are safely isolated from the main circuit.

**Environment**

	During Operation	In Storage	During Transportation
Ambient temperature	-10 °C to +50 °C (non-freezing)	-20 °C to +65 °C	-20 °C to +65 °C
Ambient humidity	90 % RH or less	90 % RH or less	90 % RH or less
Maximum altitude	1000m	1000m	10000m

**Wiring protection**

Provide the appropriate UL and cUL listed class T type fuse that are suitable for branch circuit protection in accordance with the table below.

FR-D720S-□□□-EC (C)		008	014	025	042	070	100
Rated voltage [V]		240 V or more					
Fuse maximum allowable rating [A] *	Without power factor improving reactor	15	20	20	30	40	60
	With power factor improving reactor	15	20	20	20	30	50

FR-D740-□□□-EC (C)		012	022	036	050	080	120	160
Rated voltage [V]		480 V or more						
Fuse maximum allowable rating [A] *	Without power factor improving reactor	6	10	15	20	30	40	70
	With power factor improving reactor	6	10	10	15	25	35	60

\* Maximum allowable rating by US National Electrical Code. Exact size must be chosen for each installation.



**Motor overload protection**

When using the electronic thermal relay as motor overload protection, set the rated motor current to Pr. 9 *Electronic thermal O/L relay*.

**Electronic thermal relay function characteristic**

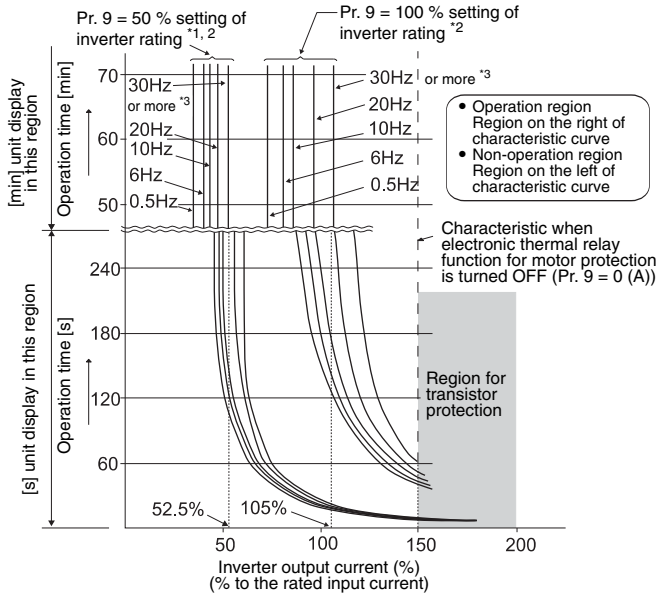

This function detects the overload (overheat) of the motor, stops the operation of the inverter's output transistor, and stops the output.

When using the Mitsubishi constant-torque motor set "1" or any of "13", "50" or "53" in Pr. 71. This provides a 100 % continuous torque characteristic in the low-speed range. Set the rated current of the motor in Pr. 9.

<sup>\*1</sup> When a value 50 % of the inverter rated output current (current value) is set in Pr. 9.

<sup>\*2</sup> The % value denotes the percentage to the inverter rated output current. It is not the percentage to the motor rated current.

<sup>\*3</sup> When you set the electronic thermal relay function dedicated to the Mitsubishi constant-torque motor, this characteristic curve applies to operation at 6 Hz or higher.

**CAUTION**

- Protective function by electronic thermal relay function is reset by inverter power reset and reset signal input. Avoid unnecessary reset and power-off.
- When multiple motors are operated by a single inverter, protection cannot be provided by the electronic thermal relay function. Install an external thermal relay to each motor.
- When the difference between the inverter and motor capacities is large and the setting is small, the protective characteristics of the electronic thermal relay function will be deteriorated. In this case, use an external thermal relay.
- A special motor cannot be protected by the electronic thermal relay function. Use an external thermal relay.
- Electronic thermal relay does not function when 5 % or less of inverter rated current is set to electronic thermal relay setting.

**A.1.3 Short circuit ratings**

- 200 V class  
Suitable for use in a circuit capable of delivering not more than 5 kA rms symmetrical amperes, 264 V maximum.
- 400 V class  
Suitable for use in a circuit capable of delivering not more than 5 kA rms symmetrical amperes, 528 V maximum.

## A.2 Instructions for UL and cUL

(UL 508C, CSA C22.2 No.14)

### A.2.1 General precaution

The bus capacitor discharge time is 10 minutes. Before starting wiring or inspection, switch power off, wait for more than 10 minutes, and check for residual voltage between terminal + and – with a meter etc., to avoid a hazard of electrical shock.

### A.2.2 Installation

The below types of inverter have been approved as products for use in enclosure and approval tests were conducted under the following conditions.

Design an enclosure so that the inverter ambient temperature, humidity and atmosphere satisfy the specifications. (Refer to *page 2*.)

#### Wiring protection

For installation in the United States, branch circuit protection must be provided in accordance with the National Electrical Code and any applicable provincial codes.

For installation in Canada, branch circuit protection must be provided in accordance with the Canada Electrical Code and any applicable provincial codes.

As specified, UL Class T fuses or any faster acting fuse with the appropriate rating must be employed.

FR-D720S-□□□-EC (C)		008	014	025	042	070	100
Rated voltage [V]		240 V or more					
Fuse maximum allowable rating [A] *	Without power factor improving reactor	15	20	20	30	40	60
	With power factor improving reactor	15	20	20	20	30	50

FR-D740-□□□-EC (C)		012	022	036	050	080	120	160
Rated voltage [V]		480 V or more						
Fuse maximum allowable rating [A] *	Without power factor improving reactor	6	10	15	20	30	40	70
	With power factor improving reactor	6	10	10	15	25	35	60

\* Maximum allowable rating by US National Electrical Code. Exact size must be chosen for each installation.

### A.2.3 Short circuit ratings

- 200 V class  
Suitable for use in a circuit capable of delivering not more than 100 kA rms symmetrical amperes, 264 V maximum.
- 400 V class  
Suitable for use in a circuit capable of delivering not more than 100 kA rms symmetrical amperes, 528 V maximum.

### A.2.4 Wiring

- The cables used should be 75 °C copper cables.
- Tighten the terminal screws to the specified torques.  
Undertightening can cause a short or misoperation.  
Overtightening can cause the screws and unit to be damaged, resulting in a short or misoperation.
- Use the UL approved round crimping terminals. Crimp the terminals with the crimping tool recommended by the terminal manufacturer.



## A.2.5 Motor overload protection

When using the electronic thermal relay as motor overload protection, set the rated motor current to Pr. 9 *Electronic thermal O/L relay*.

### Electronic thermal relay function characteristic

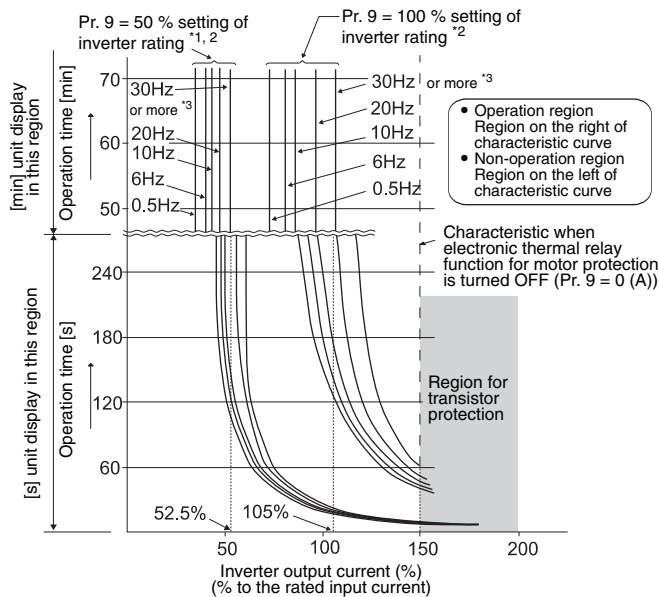

This function detects the overload (overheat) of the motor, stops the operation of the inverter's output transistor, and stops the output.

When using the Mitsubishi constant-torque motor set "1" or any of "13", "50" or "53" in Pr. 71. This provides a 100 % continuous torque characteristic in the low-speed range. Set the rated current of the motor in Pr. 9.

<sup>1</sup> When a value 50 % of the inverter rated output current (current value) is set in Pr. 9.

<sup>2</sup> The % value denotes the percentage to the inverter rated output current. It is not the percentage to the motor rated current.

<sup>3</sup> When you set the electronic thermal relay function dedicated to the Mitsubishi constant-torque motor, this characteristic curve applies to operation at 6 Hz or higher.

### CAUTION

- Protective function by electronic thermal relay function is reset by inverter power reset and reset signal input. Avoid unnecessary reset and power-off.
- When multiple motors are operated by a single inverter, protection cannot be provided by the electronic thermal relay function. Install an external thermal relay to each motor.
- When the difference between the inverter and motor capacities is large and the setting is small, the protective characteristics of the electronic thermal relay function will be deteriorated. In this case, use an external thermal relay.
- A special motor cannot be protected by the electronic thermal relay function. Use an external thermal relay.
- Electronic thermal relay does not function when 5 % or less of inverter rated current is set to electronic thermal relay setting.

## About the CD ROM

- The copyright and other rights of this enclosed CD ROM all belong to Mitsubishi Electric Corporation.
- No part of this CD ROM may be copied or reproduced without the permission of Mitsubishi Electric Corporation.
- Specifications of this CD ROM are subject to change without notice.
- We are not responsible for any damages and lost earnings, etc. from use of this CD ROM.
- Microsoft, Windows, Microsoft Windows NT are registered trademarks of Microsoft Corporation in the United States and/or other countries. Adobe and Acrobat are registered trademarks of Adobe Systems Incorporated. Pentium is a registered trademark of Intel Corporation of the United States and/or other countries. Mac OS is a registered trademark of Apple Computer, Inc., U.S.A. PowerPC is a registered trademark of International Business Machines Corporation. Other company and product names herein are the trademarks and registered trademarks of their respective owners.
- Warranty
  - We do not provide a warranty against defects in this CD ROM and related documents.
  - We are not responsible to any loss resulting from use of this product.
- Acrobat Reader

For use of Acrobat Reader contained in this CD ROM, please follow use conditions established by Adobe System Incorporated.

### WARNING

- This is a personal computer dedicated CD ROM. Do not attempt to play it on ordinary audio devices. The loud volume may damage hearing and speakers.

## When playing the CD ROM on Windows OS

### Operating environment

The following system is required to read instruction manuals contained in this CD ROM:

Item	Specifications
OS	Microsoft Windows 95 OSR 2.0, Windows 98 Second Edition, Windows Millennium Edition, Windows NT 4.0 with Service Pack 6, Windows 2000 with Service Pack 2, Windows XP Professional or Home Edition, Windows XP Tablet PC Edition
CPU	Intel Pentium processor
Memory	64MB of RAM
Hard disk	24MB of available hard disk space
CD ROM drive	Double speed or more (more than quadruple speed is recommended)
Monitor	800x600 dot or more
Application	Acrobat Reader 4.05 or more (This CD ROM contains Acrobat Reader 5.0. Install Acrobat Reader contained in the CD ROM or download Acrobat Reader from the internet)

### Operating method of this CD ROM:

- Acrobat Reader 5.0 installation procedure
  - ① Start Windows and place this CD ROM in the CD ROM drive.
  - ② If Acrobat Reader is not installed in your computer, an installation screen of Acrobat Reader is automatically displayed.
  - ③ Install according to the instruction of installation screen of Acrobat Reader.

#### Manual installation

- ① Start Windows and place this CD ROM in the CD ROM drive.
- ② Select a CD ROM drive (example: D drive) of "My computer" and click the right mouse button. Then, click "open" in the context menu.
- ③ Open "WINDOWS" folder in "ACROBAT" folder in the opened folder and execute AR505ENU.EXE.
- ④ Install according to the instruction of installation screen of Acrobat Reader.

- How to read instruction manual

- ① Start Windows and place this CD ROM in the CD ROM drive.
- ② "700 series documentation" PDF automatically opens.
- ③ Click a PDF file name of the manual you want to read in the "INSTRUCTION MANUAL" list.
- ④ PDF manual you clicked opens.

#### Manual opening of this CD ROM

- ① Start Windows and place this CD ROM in the CD ROM drive.
- ② Select a CD ROM drive (example: D drive) of "My computer" and click the right mouse button. Then, click "open" in the context menu.
- ③ Open "INDEX.PDF" in the opened folder
- ④ "700 series documentation" PDF opens. Operates according to the steps from Step ③ of "How to read instruction manual"

## When playing this CD ROM on Macintosh OS

Item	Specifications
OS	Mac OS 8.6, 9.0.4, 9.1, or Mac OS X* (* Some features may not be available.)
CPU	PowerPC processor
Memory	64MB of RAM
Hard disk	24MB of available hard disk space
CD ROM drive	Double speed or more (more than quadruple speed is recommended)
Monitor	800x600 dot or more
Application	Acrobat Reader 4.05 or more (This CD ROM contains Acrobat Reader 5.0. Install Acrobat Reader contained in the CD ROM or download Acrobat Reader from the internet)

- Operating method of this CD ROM

- ① Start Macintosh and place this CD ROM in the CD ROM drive.
- ② Double click on the CD ROM icon on the desk top to open the CD ROM.
- ③ Open "MacOS" folder in "ACROBAT" folder in the opened folder and execute Acrobat Reader Installer.
- ④ Install according to the instruction of installation screen of Acrobat Reader.

- How to read instruction manuals

- ① Start Macintosh and place this CD ROM in the CD ROM drive.
- ② Double click on the CD ROM icon on the desk top to open the CD ROM.
- ③ Open "INDEX.PDF" in the opened folder.
- ④ "700 series documentation" PDF opens.
- ⑤ Click a PDF file name of the manual you want to read in the "INSTRUCTION MANUAL" list.
- ⑥ PDF manual you clicked opens.

**HEADQUARTERS**

MITSUBISHI ELECTRIC EUROPE B.V. **EUROPE**  
 German Branch  
 Gothaer Straße 8  
**D-40880 Ratingen**  
 Phone: +49 (0)2102 / 486-0  
 Fax: +49 (0)2102 / 486-1120

MITSUBISHI ELECTRIC EUROPE B.V. **CZECH REPUBLIC**  
 Czech Branch  
 Avenir Business Park, Radlická 714/113a  
**CZ-158 00 Praha 5**  
 Phone: +420 (0)251 551 470  
 Fax: +420 (0)251-551-471

MITSUBISHI ELECTRIC EUROPE B.V. **FRANCE**  
 French Branch  
 25, Boulevard des Bouvets  
**F-92741 Nanterre Cedex**  
 Phone: +33 (0)1 / 55 68 55 68  
 Fax: +33 (0)1 / 55 68 57 57

MITSUBISHI ELECTRIC EUROPE B.V. **IRELAND**  
 Irish Branch  
 Westgate Business Park, Ballymount  
**IRL-Dublin 24**  
 Phone: +353 (0)1 4198800  
 Fax: +353 (0)1 4198890

MITSUBISHI ELECTRIC EUROPE B.V. **ITALY**  
 Italian Branch  
 Viale Colleoni 7  
**I-20041 Agrate Brianza (MB)**  
 Phone: +39 039 / 60 53 1  
 Fax: +39 039 / 60 53 312

MITSUBISHI ELECTRIC EUROPE B.V. **POLAND**  
 Poland Branch  
 Krakowska 50  
**PL-32-083 Balice**  
 Phone: +48 (0)12 / 630 47 00  
 Fax: +48 (0)12 / 630 47 01

MITSUBISHI ELECTRIC EUROPE B.V. **SPAIN**  
 Spanish Branch  
 Carretera de Rubí 76-80  
**E-08190 Sant Cugat del Vallés (Barcelona)**  
 Phone: 902 131121 // +34 935653131  
 Fax: +34 935891579

MITSUBISHI ELECTRIC EUROPE B.V. **UK**  
 UK Branch  
 Travellers Lane  
**UK-Hatfield, Herts. AL10 8XB**  
 Phone: +44 (0)1707 / 27 61 00  
 Fax: +44 (0)1707 / 27 86 95

MITSUBISHI ELECTRIC CORPORATION **JAPAN**  
 Office Tower "Z" 14 F  
 8-12, 1 chome, Harumi Chuo-Ku  
**Tokyo 104-6212**  
 Phone: +81 3 622 160 60  
 Fax: +81 3 622 160 75

MITSUBISHI ELECTRIC AUTOMATION, Inc. **USA**  
 500 Corporate Woods Parkway  
**Vernon Hills, IL 60061**  
 Phone: +1 847 478 21 00  
 Fax: +1 847 478 22 53

**EUROPEAN REPRESENTATIVES**

GEVA **AUSTRIA**  
 Wiener Straße 89  
**AT-2500 Baden**  
 Phone: +43 (0)2252 / 85 55 20  
 Fax: +43 (0)2252 / 488 60

TEHNIKON **BELARUS**  
 Oktyabrskaya 16/5, Off. 703-711  
**BY-220030 Minsk**  
 Phone: +375 (0)17 / 210 46 26  
 Fax: +375 (0)17 / 210 46 26

ESCO DRIVES & AUTOMATION **BELGIUM**  
 Culliganlaan 3  
**BE-1831 Diegem**  
 Phone: +32 (0)2 / 717 64 30  
 Fax: +32 (0)2 / 717 64 31

Koning & Hartman b.v. **BELGIUM**  
 Woluwelaan 31  
**BE-1800 Vilvoorde**  
 Phone: +32 (0)2 / 257 02 40  
 Fax: +32 (0)2 / 257 02 49

INEA BH d.o.o. **BOSNIA AND HERZEGOVINA**  
 Aleja Lipa 56  
**BA-71000 Sarajevo**  
 Phone: +387 (0)33 / 921 164  
 Fax: +387 (0)33 / 524 539

AKHNATON **BULGARIA**  
 4 Andrej Ljapchev Blvd. Pb 21  
**BG-1756 Sofia**  
 Phone: +359 (0)2 / 817 6004  
 Fax: +359 (0)2 / 97 44 06 1

INEA CR d.o.o. **CROATIA**  
 Losinjska 4 a  
**HR-10000 Zagreb**  
 Phone: +385 (0)1 / 36 940 - 01 / -02 / -03  
 Fax: +385 (0)1 / 36 940 - 03

AutoCont C.S. s.r.o. **CZECH REPUBLIC**  
 Technologická 374/6  
**CZ-708 00 Ostrava-Pustkovce**  
 Phone: +420 595 691 150  
 Fax: +420 595 691 199

B:ELECTRIC, s.r.o. **CZECH REPUBLIC**  
 Mladoboleslavská 812  
**CZ-197 00 Praha 19 - Kbely**  
 Phone: +420 286 850 848, +420 724 317 975  
 Fax: +420 286 850 850

Beijer Electronics A/S **DENMARK**  
 Lykkegårdsvej 17, 1.  
**DK-4000 Roskilde**  
 Phone: +45 (0)46 / 75 76 66  
 Fax: +45 (0)46 / 75 56 26

Beijer Electronics Eesti OÜ **ESTONIA**  
 Pärnu mnt.160i  
**EE-11317 Tallinn**  
 Phone: +372 (0)6 / 51 81 40  
 Fax: +372 (0)6 / 51 81 49

Beijer Electronics OY **FINLAND**  
 Jaakonkatu 2  
**FIN-01620 Vantaa**  
 Phone: +358 (0)207 / 463 500  
 Fax: +358 (0)207 / 463 501

UTECO A.B.E.E. **GREECE**  
 5, Mavrogenous Str.  
**GR-18542 Piraeus**  
 Phone: +30 211 / 1206 900  
 Fax: +30 211 / 1206 999

MELTRADE Ltd. **HUNGARY**  
 Fertő utca 14.  
**HU-1107 Budapest**  
 Phone: +36 (0)1 / 431-9726  
 Fax: +36 (0)1 / 431-9727

Beijer Electronics SIA **LATVIA**  
 Vestienas iela 2  
**LV-1035 Riga**  
 Phone: +371 (0)784 / 2280  
 Fax: +371 (0)784 / 2281

Beijer Electronics UAB **LITHUANIA**  
 Savanoriu Pr. 187  
**LT-02300 Vilnius**  
 Phone: +370 (0)5 / 232 3101  
 Fax: +370 (0)5 / 232 2980

**EUROPEAN REPRESENTATIVES**

ALFATRADE Ltd. **MALTA**  
 99, Paola Hill  
**Malta- Paola PLA 1702**  
 Phone: +356 (0)21 / 697 816  
 Fax: +356 (0)21 / 697 817

INTEHSIS srl **MOLDOVA**  
 bld. Traian 23/1  
**MD-2060 Kishinev**  
 Phone: +373 (0)22 / 66 4242  
 Fax: +373 (0)22 / 66 4280

HIFLEX AUTOM.TECHNIEK B.V. **NETHERLANDS**  
 Wolveverstraat 22  
**NL-2984 CD Ridderkerk**  
 Phone: +31 (0)180 - 46 60 04  
 Fax: +31 (0)180 - 44 23 55

Koning & Hartman b.v. **NETHERLANDS**  
 Haarlbergweg 21-23  
**NL-1101 CH Amsterdam**  
 Phone: +31 (0)20 / 587 76 00  
 Fax: +31 (0)20 / 587 76 05

Beijer Electronics AS **NORWAY**  
 Postboks 487  
**NO-3002 Drammen**  
 Phone: +47 (0)32 / 24 30 00  
 Fax: +47 (0)32 / 84 85 77

Sirius Trading & Services srl **ROMANIA**  
 Aleea Lacul Morii Nr. 3  
**RO-060841 Bucuresti, Sector 6**  
 Phone: +40 (0)21 / 430 40 06  
 Fax: +40 (0)21 / 430 40 02

Craft Con. & Engineering d.o.o. **SERBIA**  
 Bulevar Svetog Cara Konstantina 80-86  
**SER-18106 Nis**  
 Phone: +381 (0)18 / 292-24-4/5  
 Fax: +381 (0)18 / 292-24-4/5

INEA SR d.o.o. **SERBIA**  
 Izletnicka 10  
**SER-113000 Smederevo**  
 Phone: +381 (0)26 / 617 163  
 Fax: +381 (0)26 / 617 163

AutoCont Control s.r.o. **SLOVAKIA**  
 Radlinského 47  
**SK-02601 Dolny Kubin**  
 Phone: +421 (0)43 / 5868210  
 Fax: +421 (0)43 / 5868210

CS MTrade Slovensko, s.r.o. **SLOVAKIA**  
 Vajanskeho 58  
**SK-92101 Piestany**  
 Phone: +421 (0)33 / 7742 760  
 Fax: +421 (0)33 / 7735 144

INEA d.o.o. **SLOVENIA**  
 Stegne 11  
**SI-1000 Ljubljana**  
 Phone: +386 (0)1 / 513 8100  
 Fax: +386 (0)1 / 513 8170

Beijer Electronics AB **SWEDEN**  
 Box 426  
**SE-20124 Malmö**  
 Phone: +46 (0)40 / 35 86 00  
 Fax: +46 (0)40 / 35 86 02

Econotec AG **SWITZERLAND**  
 Hinterdorfstr. 12  
**CH-8309 Nürensdorf**  
 Phone: +41 (0)44 / 838 48 11  
 Fax: +41 (0)44 / 838 48 12

GTS **TURKEY**  
 Bayraktar Bulvari Nutuk Sok. No:5  
**TR-34775 Yukari Dudullu-Umraniye-ISTANBUL**  
 Phone: +90 (0)216 526 39 90  
 Fax: +90 (0)216 526 3995

CSC Automation Ltd. **UKRAINE**  
 4-B, M. Raskovoyi St.  
**UA-02660 Kiev**  
 Phone: +380 (0)44 / 494 33 55  
 Fax: +380 (0)44 / 494-33-66

**EURASIAN REPRESENTATIVES**

Kazpromautomatiks Ltd. **KAZAKHSTAN**  
 Mustafina Str. 7/2  
**KAZ-470046 Karaganda**  
 Phone: +7 7212 / 50 11 50  
 Fax: +7 7212 / 50 11 50

**MIDDLE EAST REPRESENTATIVE**

SHERF Motion Techn. Ltd. **ISRAEL**  
 Rehov Hamerkava 19  
**IL-58851 Holon**  
 Phone: +972 (0)3 / 559 54 62  
 Fax: +972 (0)3 / 556 01 82

CEG INTERNATIONAL **LEBANON**  
 Cebaco Center/Block A Autostrade DORA  
**Lebanon - Beirut**  
 Phone: +961 (0)1 / 240 430  
 Fax: +961 (0)1 / 240 438

**AFRICAN REPRESENTATIVE**

CBI Ltd. **SOUTH AFRICA**  
 Private Bag 2016  
**ZA-1600 Isando**  
 Phone: +27 (0)11 / 928 2000  
 Fax: +27 (0)11 / 392 2354