



**SOLID STATE
SOFT STARTER**

ASTAT Plus

USER MANUAL

REMARKS :

1. Read this manual thoroughly before using the ASTAT Plus, and store in a safe place for reference.
2. Make sure that this manual is delivered to the end user
3. **CE MARKING**
When using ASTAT Plus in the EU, compliance with EMC is required.
ASTAT Plus range comply with the generic EN 50081-2 and EN 50082-2

ASTAT Plus. Soft Starters

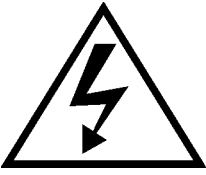

WARNINGS

1. Disconnect power before installing or servicing.
2. Hazardous voltages are present in the motor circuit even when the starter is OFF. An isolation contactor is recommended, configured to provide automatic isolation when the motor is turned OFF.
3. Unit may contain more than one live circuit. Disconnect both control and main circuits before installing or servicing.
4. Soft stop should not be used as an Emergency stop.
5. Stopping mode must be set to meet applicable standards for operator safety.
6. Separate motor overcurrent protection is required to be provided in accordance with the Canadian Electrical Code, Part 1. ASTAT Plus provides separate motor protection.

CAUTIONS

1. Semi-conductor fuses specified may not provide branch circuit protection. Refer to local applicable electrical codes.
2. Overload relay setting should be properly coordinated with motor.
3. Slow speed running will affect the motor thermal characteristic due to reduced cooling. Care must be taken when operating motor under these conditions.
4. DC braking - braking current may cause motor overheating. Select the lowest braking current and time.
5. DC braking must use additional (DC3) in the motor circuit. See wiring diagram page 6-1.
6. Abnormal starting times in excess of 30 seconds, or closely repeated operations of acceleration ramp/deceleration ramp, slow speed, or DC injection braking may cause motor damage. Contact motor manufacturer for proper motor selection.
7. If control power is lost between starts, the overload relay protection is reset to cold start conditions.

ASTAT Plus. Soft Starters

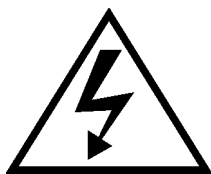

PRECAUTIONS

1. Debranchez l'alimentation en courant électrique avant de raccorder ou d'intervenir.
2. Des tensions dangereuses sont présentes dans le circuit moteur même si le soft starter indique la position "arrêt". Un contacteur d'isolement assurant un isolement automatique quand le moteur est arrêté, est recommandé.
3. L'appareil peut renfermer plus d'un circuit sous tension de brancher les circuits principaux et les circuits de contrôle avant de raccorder ou d'intervenir.
4. Délestage "soft stop" ne devrait jamais être utilisé en lieu de délestage d'urgence.
5. Procédés de délestage doivent être conformes aux normes de sécurité des utilisateurs.

AVERTISSEMENTS

1. Les fusibles semi-conducteurs spécifiés ne protègent pas obligatoirement les circuits se conformer aux codes locaux d'installations électriques.
2. Le relais de courant de surcharge doit être correctement coordonné avec la marche du moteur.
3. La marche en sous-régime agit sur les caractéristiques thermiques à cause de la réduction de refroidissement. Opérez le moteur avec précaution dans ce cas.
4. Ralentissement courant continu peut provoquer la surchauffe du moteur. Choisissez le plus faible courant de décélération et la durée de ralentissement la plus courte.
5. Pour le freinage courant continu, un contacteur (DC3) supplémentaire est nécessaire dans le circuit moteur, voir le schéma de raccordement page 6-1.
6. Les délais anormaux de mise en service d'une durée supérieure à 30 secondes, ainsi que les montées/descentes en régime, les exploitations régime lent ou les freinages par injection de courant continu répétés et rapprochés sont susceptibles d'endommager le moteur. Mettez-vous en rapport avec votre fabricant en ce qui concerne le choix du moteur adéquat.
7. En cas d'interruption de l'alimentation entre deux démarrages, la protection assurée par le démarrage à froid.
8. Le moteur doit être muni d'une protection distincte contre les surintensités, et la surchauffe conformément au code de l'électricité, première partie. ASTAT Plus le relais de courant de surcharge doit être correctement coordonné avec la marche du moteur.

INDEX

Section 1. Generalities	1-1
1-1 Comparison of starting systems	1-1
1-2 Advantages of the ASTAT Plus Solid State Soft Starters	1-2
Section 2. Types and Ratings	2-1
2-1 IEC ratings	2-1
2-2 UL ratings	2-2
2-3 Thermal characteristics	2-2
Section 3. Technical specifications	3-1
3-1 General Specifications	3-1
3-2 I/O Terminal Board Specification	3-2
3-3 I/O Wiring	3-3
3-4 Operating modes	3-4
Section 4. Programming.	4-1
4-1 Keypad and display description	4-1
4-2 Parameter configuration	4-2
4-3 Monitor block parameters	4-4
4-4 Calibration block parameters	4-5
4-5 Basic block parameters	4-6
4-6 Advanced block parameters	4-7
Section 5. Installation.	5-1
5-1 Equipment installation	5-1
5-2 Fuses, contactors and supply wiring	5-2
5-3 Start-up	5-3
5-4 Troubleshooting	5-3
5-5 Thyristor Check	5-4
Section 6. Appendix.	6-1
6-1 Application Diagrams	6-1
6-2 Serial Communications	6-4
6-3 Dimensions	6-7
6.4 PCB's Layout	6-8

1. Generalities

1-1. Comparison of starting systems

There are numerous applications where soft starting and limited current peak are needed and thereby making direct starting of squirrel-cage motors impossible. Traditionally in such cases other types of starting with reduced stator voltage have been resorted to. The best-known are star-delta starters, autotransformer starters, stator resistance starters or using part winding motors.

Any reduced starting voltage imposes a current limitation, and as a consequence the starting torque is also reduced, but there will always be peaks during the change from one point or state to another which can damage the machine being driven. In order to analyse the performances offered by each of these different types of starters, the following table shows the special characteristics of each of them, comparing with the ASTAT system.

Note that in general all reduced voltage starts produce a reduction in torque in squared proportion to the current in the phases of the motor (not on the line) and the latter in turn is reduced in linear proportion to the voltage. From this it can be deduced that any start with reduced voltage reduces the torque in squared proportion to the voltage per motor phase. From this point of view soft starting produces, just like any other reduced voltage start, a reduction in starting torque, according

to the adjusted parameters. The advantage, of course, is the ease with which this ramp can be controlled to produce a soft start in accordance with the actual requirement of the machine.

From the comparison table it can be seen that the maximum starting torque attainable using the soft system is 90% of that which direct starting tends to. Bearing in mind that the direct starting torque varies between 1.5 and 2.4 times rated torque, it can be deduced that with the soft starter, starting torques which are somewhat higher than rated are obtained.

This area includes the starting of pumps, fans, conveyor belts, etc., where a torque in the region of 60% of rated is usually sufficient for correct starting.

As a general rule it can be guaranteed that soft starter will allow starting of drives which are currently used in conventional starting systems, with the advantages outlined, and above all the facility to adjust the current peaks and torque at the machine, faced with the impossibility or difficulty of varying the steps in conventional systems.

	CONVENTIONAL STARTERS					SOFT STARTER
	Direct	Autotransfo	Stator resistance	Part winding motor	Star-delta	
% of direct start current (in the line)	100%	30 - 40 or 64%	58 - 70%	65%	33%	Depending on adjust, max. 90%
% of direct start torque	100%	30 - 40 or 64%	33 - 49%	48%	33%	Depending on adjust, max. 90%
Starting steps (1)	1	4, 3 or 2	3 or 2	2	2	Continuous, no steps
Connections to motor	3	3	3	6	6	3
Line overload (approx.)	5 I _n	1,5 - 2,1 or 3,2 I _n	3 - 3,5 I _n	3,25 I _n	1,65 I _n	Depending on adjust, max. 4-7 I _n
Change or starting pause	NO	NO	NO	NO	YES	NO

(1) "Steps" mean sharp changes of speed during the time from rest until rated speed is reached.

1. Generalities

1-2. Advantages of the ASTAT Plus Solid State Soft starter

1 Increase in productivity and reliability with the use of static soft starters.

Starting and stopping the motor without steps or transitions lengthens the life of power-driven machine mechanical elements, greatly reducing stress on transmission and coupling parts.

Consequently, overhauling times are reduced and machine and facility lifespans are lengthened.

2 Improvement in acceleration / deceleration characteristics

Being able to start by using the voltage ramp or alternatively by limiting current lets acceleration fit the load characteristics. Application of a pulse start may also be selected in cases of high static friction load.

Braking may be made by cutting-off power or by stop ramp, and it is also possible to brake more energetically by feeding a DC current to the motor stator, so there are many ways to obtain the best possible deceleration.

3 Protected motor

The soft starter protects the motor from overloads as well as from incorrect operating conditions such as loss of an input or output phase, blocked rotor, thyristor short circuit, etc.

4 Digital technology

The control system is based on the use of a highly specialized microcontroller by which signals are treated digitally, thereby avoiding deratings and adjustments common to analogue circuits and obtaining excellent precision and speed of execution.

The control board is made with the technology of surface mounting devices (SMD), which increases equipment reliability.

5 High level of immunity

Design of the unit was closely tied to the conditions of supply lines, which handle more disturbance every day. The control signals are optoelectronically isolated and various levels of protection have been set up in the circuits to immunize the equipment against external disturbance and its effects.

6 Easy to run and adjust

This unit can be used for a wide range of applications.

Adjustments are very easy to make and diverse options may be selected to have equipment capabilities suited to application needs every time.

7 Easy maintenance due to full monitoring

The signalling code based on alphanumeric display, makes the equipment working conditions known at any time and gives a quick diagnosis when protection security is violated.

8 Pump control

The ASTAT Plus includes a Pump Control function which is more effective than the standard soft stop, reducing fluid surges or hammering in a pipe line system. This method reduces the motor speed, by controlling internal parameters in the motor as well as the output voltage in a close-loop system.

9 Advanced functions

The ASTAT Plus includes advanced functions, like linear acceleration ramp, forward and reverse jog, programmable I/O or connection to a computer by serial communication (RS 232), all included as standard.

These performances allows the incorporation of the soft starter to a distributed control net, in automated plant processes, together with other soft starters, programmable controllers, variable speed drives, etc.

2. Types and ratings

2-1. IEC Ratings (1)

HEAVY DUTY					LIGHT DUTY					Degree of protection	TYPE	Weight unit	Cooled
Current rating (2)	220V / 240V	380V / 415V	440V	480V / 500V	Current rating (3)	220V / 240V	380V / 415V	440V	480V / 500V				
A	kW(4)	kW(4)	kW(4)	kW(4)	A	kW(5)	kW(5)	kW(5)	kW(5)		Kg.		
14	3	5.5	7.5	-	17	4	7.5	7.5	-	IP-00	QC1FDP QC2FDP	4,3	Natural
	3	5.5	7.5	7.5		4	7.5	7.5	11	IP-00		4,3	Natural
17	4	7.5	7.5	-	21	5.5	11	11	-	IP-00	QC1GDP QC2GDP	4,3	Natural
	4	7.5	7.5	11		5.5	11	11	13	IP-00		4,3	Natural
22	5.5	11	11	-	27	7.5	13	15	-	IP-00	QC1HDP QC2HDP	4,6	Natural
	5.5	11	11	15		7.5	13	15	15	IP-00		4,6	Natural
32	7.5	15	18.5	-	38	10	18.5	22	-	IP-00	QC1IDP QC2IDP	4,6	Natural
	7.5	15	18.5	22		10	18.5	22	25	IP-00		4,6	Natural
48	13	22	22	-	58	15	25	30	-	IP-00	QC1JDP QC2JDP	12,5	By fan
	13	22	22	30		15	25	30	37	IP-00		12,5	By fan
63	15	30	37	-	75	22	37	45	-	IP-00	QC1KDP QC2KDP	12,5	By fan
	15	30	37	37		22	37	45	45	IP-00		12,5	By fan
72	20	37	37	-	86	25	45	50	-	IP-00	QC1LDP QC2LDP	17,0	By fan
	20	37	37	45		25	45	50	50	IP-00		17,0	By fan
105	30	55	55	-	126	37	63	75	-	IP-00	QC1MDP QC2MDP	17,0	By fan
	30	55	55	75		37	63	75	80	IP-00		17,0	By fan
156	40	75	90	-	187	55	90	110	-	IP-00	QC1NDP QC2NDP	45,0	By fan
	40	75	90	110		55	90	110	132	IP-00		45,0	By fan
240	63	110	132	-	288	80	150	165	-	IP-00	QC1QDP QC2QDP	45,0	By fan
	63	110	132	160		80	150	165	200	IP-00		45,0	By fan
315	90	160	200	-	378	110	200	220	-	IP-00	QC1RDP QC2RDP	55,0	By fan
	90	160	200	220		110	200	220	250	IP-00		55,0	By fan
370	110	200	220	-	444	132	220	250	-	IP-00	QC1SDP QC2SDP	55,0	By fan
	110	200	220	250		132	220	250	315	IP-00		55,0	By fan
475	150	250	250	-	570	160	300	355	-	IP-00	QC1TDP QC2TDP	80,0	By fan
	150	250	250	335		160	300	355	400	IP-00		80,0	By fan
610	200	315	400	-	732	220	400	450	-	IP-00	QC1UDP QC2UDP	105,0	By fan
	200	315	400	400		220	400	450	500	IP-00		105,0	By fan
850	250	450	530	-	1020	300	560	600	-	IP-00	QC1VDP QC2VDP	120,0	By fan
	250	450	530	600		300	560	600	750	IP-00		120,0	By fan
1075	355	600	670	-	1290	395	715	750	-	IP-00	QC1XDP QC2XDP	150,0	By fan
	355	600	670	750		395	715	750	850	IP-00		150,0	By fan

Notes: (1) = Ratings in Amps. given for ambient temperature up to 40°C and 1000m altitude
Derate output current by 1,5% / °C above 40°C.
Derate output current by 1% / 100m above 1000m

(2) = Heavy duty ratings, IEC Class 10 and 20 protections allowed

(3) = Light duty ratings, only IEC Class 10 protection allowed.

(4) = Maximum recommended Motor Power for IEC Class 20 protection. Set ASTAT's parameters "N" and "o" accordingly

(5) = Maximum recommended Motor Power for IEC Class 10 protection. Set ASTAT's parameters "N" and "o" accordingly

2. Types and ratings

2-2. UL Ratings

Current rating	Max. starting current	STANDARD DUTY			HEAVY DUTY			Degree of protection	TYPE	Weight (1)	Cooled unit
		200V	230V	460V	200V	230V	460V				
A	A	HP	HP	HP	HP	HP	HP			Kg.	
14	70	3 -	3 -	- 7,5	3 -	3 -	- 7,5	IP-00 IP-00	QC1FDP QC2FDP	4,3 4,3	Natural Natural
17	85	3 -	3 -	- 10	3 -	3 -	- 10	IP-00 IP-00	QC1GDP QC2GDP	4,3 4,3	Natural Natural
22	110	5 -	7,5 -	- 15	5 -	7,5 -	- 15	IP-00 IP-00	QC1HDP QC2HDP	4,6 4,6	Natural Natural
34	170	7,5 -	7,5 -	- 20	7,5 -	7,5 -	- 20	IP-00 IP-00	QC1IDP QC2IDP	4,6 4,6	Natural Natural
48	240	15 -	15 -	- 30	10 -	15 -	- 30	IP-00 IP-00	QC1JDP QC2JDP	12,5 12,5	By fan By fan
63	315	20 -	20 -	- 40	15 -	20 -	- 40	IP-00 IP-00	QC1KDP QC2KDP	12,5 12,5	By fan By fan
72	360	20 -	25 -	- 50	20 -	20 -	- 40	IP-00 IP-00	QC1LDP QC2LDP	17,0 17,0	By fan By fan
105	525	30 -	30 -	- 75	30 -	30 -	- 60	IP-00 IP-00	QC1MDP QC2MDP	17,0 17,0	By fan By fan
156	780	50 -	60 -	- 125	40 -	50 -	- 100	IP-00 IP-00	QC1NDP QC2NDP	45,0 45,0	By fan By fan
240	1200	75 -	75 -	- 200	60 -	75 -	- 150	IP-00 IP-00	QC1QDP QC2QDP	45,0 45,0	By fan By fan
315	1575	100 -	125 -	- 250	75 -	100 -	- 200	IP-00 IP-00	QC1RDP QC2RDP	55,0 55,0	By fan By fan
370	1850	125 -	150 -	- 300	100 -	125 -	- 250	IP-00 IP-00	QC1SDP QC2SDP	55,0 55,0	By fan By fan
500	2500	150 -	200 -	- 400	150 -	150 -	- 350	IP-00 IP-00	QC1TDP QC2TDP	80,0 80,0	By fan By fan
630	3150	200 -	250 -	- 500	200 -	200 -	- 400	IP-00 IP-00	QC1UDP QC2UDP	105,0 105,0	By fan By fan
850	4250	300 -	350 -	- 700	300 -	350 -	- 700	IP-00 IP-00	QC1VDP QC2VDP	120,0 120,0	By fan By fan

2. Types and ratings

2-3. ASTAT Plus, Thermal characteristics

The ASTAT Plus allows motor protection according IEC Class 10 or Class 20 and Nema 10, 20 or 30, free selectable by parameter "o" -overload-

IEC Class 10

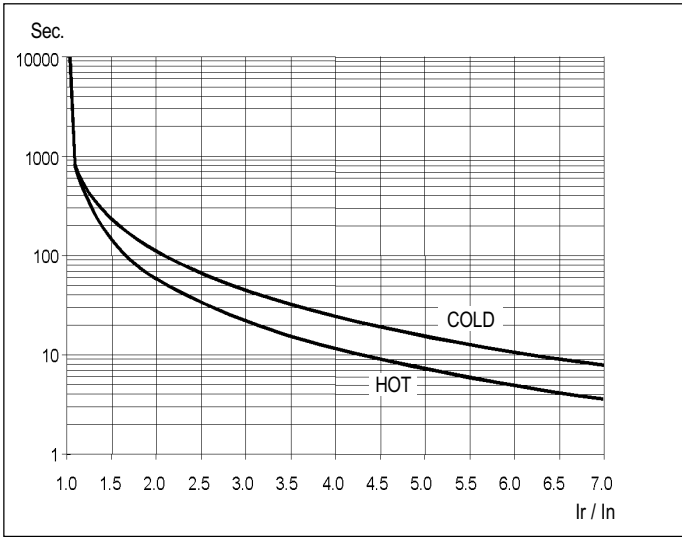

IEC Class 20

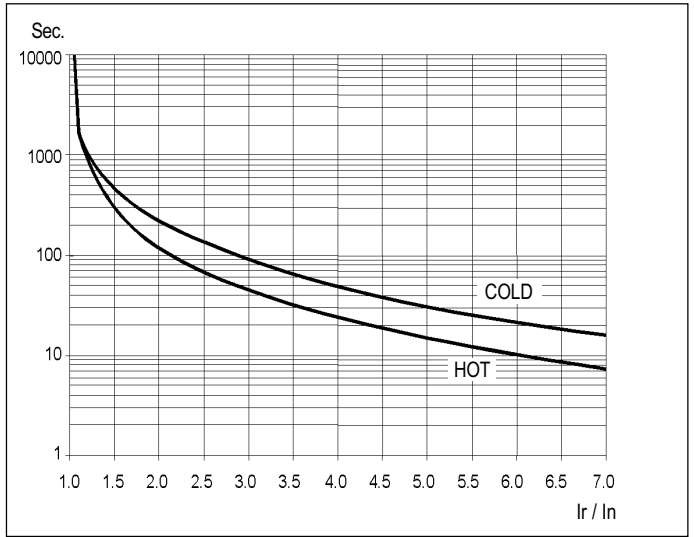

Nema 10

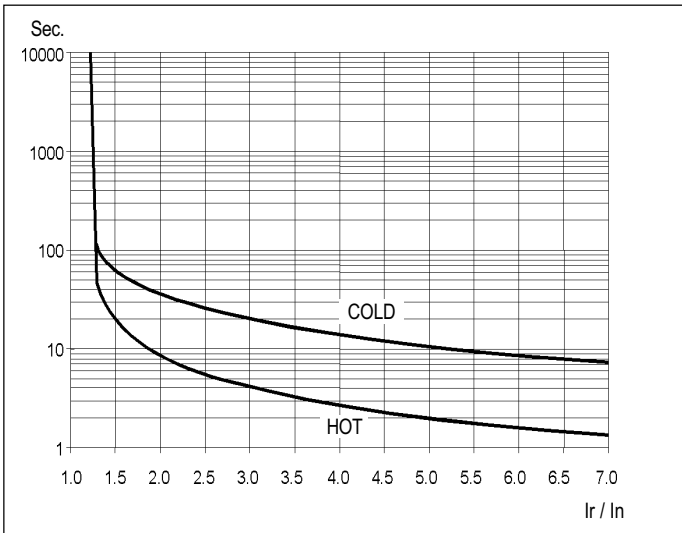

Nema 20

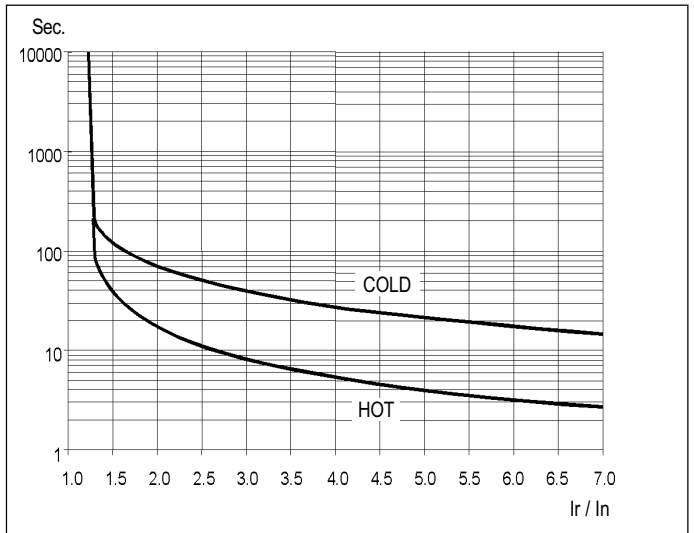

Nema 30

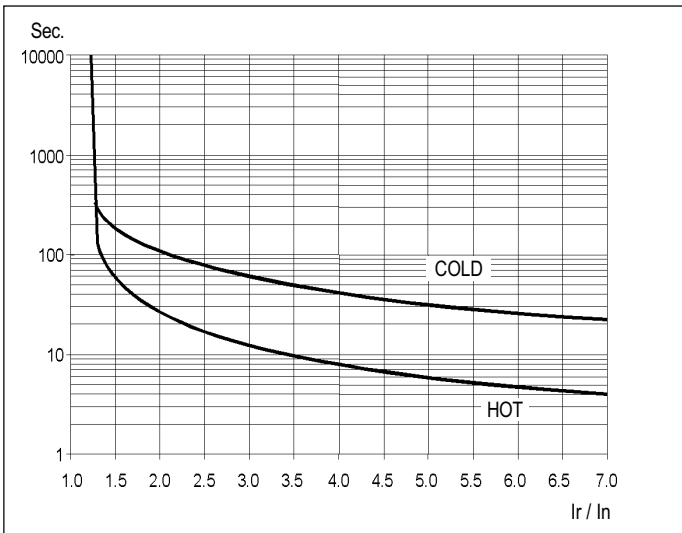

Thermal memory:

If the control voltage is not removed, the unit has a cool down characteristic, being the cool down time 300 sec. after the overload trip.

If the control voltage is removed after tripping, you must wait, at least, 2 minutes before the unit can be restarted.

Operations per hour:

Supposing a cycle T, with starting time of t1, running time of T-t1 at rated current and OFF time of t1 sec. at least, the ASTAT Plus allows the following operations per hour.

Overload	Operations / Hour. Starting time t1= 10sec.	Operations / Hour Starting time t1=20 sec.
2 Ir	180	90
3 Ir	160	60
4 Ir	30	10

3. Technical specifications

3-1. ASTAT Plus, General specifications

Voltage Ratings	3ph AC Systems		Up to 440V, +10%, -15% for QC1xDP ASTAT Plus series Up to 500V, +10%, -15% for QC2xDP ASTAT Plus series
Freq. Range	50/60	Hz	Control range of 45-65 Hz
Control Specifications	Control system		Digital system with microcontroller Starting ramp with progressive increase in voltage and current limitation
	Initial voltage (pedestal)	%	30 - 95 U_n
	Starting torque	%	10 - 90 $M_{direct\ start}$
	Kick start	%	95 U_n (90% $M_{direct\ start}$), adjustable 0 to 999 ms
	Motor current (I_m)		0,4 to 1,2 I_r (rated ASTAT current)
	Current limitation		1 to 7 I_n
	Acceleration ramp time	s	1 to 99 (types: standard or linear ramp up)
	Energy savings		Output voltage reduction according to power factor
	Override		Fixed output voltage permanently equal to supply voltage
	Bypass		Direct control of a bypass contactor
	Brake time by ramp	s	1 to 120 (1 to 99 in secondary ramp) adjustable independently of starting ramp time (types: standard, pump control or linear ramp down)
	DC braking		0 to 99 s. ; 0,5 to 2,5 I_n
	Slow speed		Direct torque: 7% or 14% of nominal speed; reverse torque: 20% of nominal speed
	Retry		0 to 4 attempts, and 1 to 99 sec. retry time
	Monitoring		Motor current, line voltage, power, power factor and elapsed time
Operation	External control		Start - Stop
	Acceleration phase		Adjustable time
	Permanent phase		Energy savings / Override choice
	Stop phase		Power cut-off / Ramp / DC braking/Pump control
Inputs / Outputs	Inputs		4 digital optocoupled. Two fixed (Start , Stop) , and 2 programmable (I3, I4)
	Outputs		1 Analog 0-5VDC for Tachogenerator input feedback 3 programmable relays, (1r, 2r, 3r) 1 Analog 0-10VDC output for current metering
Protections	Current limit		Adjustable from 1 I_n to 7 I_n
	Overload		IEC class 10 and 20 ; NEMA class 10,20 and 30 all selectable
	Cool-down time after overload trip	s	300
	Loss on input phase	s	Trip at 3
	Thyristor short circuit	ms	Trip at 200
	Radiator overheating	ms	Trip at 200
	Motor thermistor	ms	Trip at 200 if thermistor impedance > response value
	Loss on output phase	s	Trip at 3
	Stalled rotor	ms	Trip at 200
	Supply frequency error	Hz	If $f < 45$ or $f > 65$, will not start
	Overcurrent		100 to 150% I_n ; trip time adjustable from 0 to 99 sec.
	Undercurrent		0 to 99% I_n ; trip time adjustable from 0 to 99 sec.
	Overvoltage		100 to 130% U_n ; trip time adjustable from 0 to 99 sec.
	Undervoltage		0 to 50% U_n ; trip time adjustable from 0 to 99 sec.
	Error (CPU)	ms	60
	Memory		4 former errors
	Long start time	s	2 x t_a (t_a = acceleration ramp time)
	Long slow speed time	s	120
Environmental conditions	Temperature	°C	0 to +55 (derate output current by 1,5% / °C above 40°C)
	Relative humidity	%	95% without condensation
	Maximum altitude	m	3000 (derate output current by 1% / 100m above 1000m)
	Mounting position		Vertical
	Protection Degree		IP00
Standards	CE, cUL		CE Conforming IEC 947-4-2
	Conducted & Radiated emissions		Conforming IEC 947 -4-2, Class A
	Electrostatic discharges		Conforming to IEC 1000-4-2, level 3
	Radioelectric interference		Conforming to IEC 1000-4-6, level 3 and to IEC 1000-4-3, level 3
	Immunity to fast transients		Conforming to IEC 1000-4-4, level 3
	Immunity to Surge Voltage		Conforming to IEC 1000-4-5, level 3

3. Technical specifications

3-2. I/O terminal board specifications

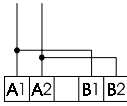
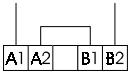
Power I/O terminals <table border="1"> <thead> <tr> <th>Terminal</th> <th>Function</th> </tr> </thead> <tbody> <tr> <td>1L1, 3L2, 5L3</td> <td>Mains Input</td> </tr> <tr> <td>2T1, 4T2, 6T3</td> <td>Motor output</td> </tr> <tr> <td>A1, A2, B1, B2</td> <td>Input Control Voltage</td> </tr> </tbody> </table>		Terminal	Function	1L1, 3L2, 5L3	Mains Input	2T1, 4T2, 6T3	Motor output	A1, A2, B1, B2	Input Control Voltage	<p>Description 3ph input voltage according ASTAT Plus type.</p> <p>Output terminals to 3ph AC motor</p> <p>110/120V AC, +10%, -15%:  ; 220/240V AC, +10%, -15%: </p>																
Terminal	Function																									
1L1, 3L2, 5L3	Mains Input																									
2T1, 4T2, 6T3	Motor output																									
A1, A2, B1, B2	Input Control Voltage																									
Digital Inputs <table border="1"> <thead> <tr> <th>Terminal</th> <th>Function</th> </tr> </thead> <tbody> <tr> <td>57</td> <td>Common for digital inputs</td> </tr> <tr> <td>1</td> <td>Run</td> </tr> <tr> <td>2</td> <td>Stop</td> </tr> <tr> <td>3</td> <td>Programmable input I3</td> </tr> <tr> <td>4</td> <td>Programmable input I4</td> </tr> </tbody> </table>		Terminal	Function	57	Common for digital inputs	1	Run	2	Stop	3	Programmable input I3	4	Programmable input I4	<p>Description This is a common terminal for the digital input terminals specified below.</p> <p>Run order. Command signal may be provided by one NO free voltage push-button to terminals 1 and 57. Stop order. Command signal may be provided by one NC free voltage push-button to terminals 2 and 57.</p> <p>Note: Run/Stop permanent command is allowed linking 1-57 and using one dry NO contact to 2-57 terminals.</p> <p>These two inputs are programmable. Can be assigned to the following internal functions</p> <table border="0"> <tbody> <tr> <td>-soft stop</td> <td>-DC brake</td> <td>-Linear Ramp</td> </tr> <tr> <td>-pump control</td> <td>-slow speed control</td> <td>-dual ramp selection</td> </tr> <tr> <td>-kick start</td> <td>-reverse slow speed</td> <td>-bypass function</td> </tr> <tr> <td>-override</td> <td>-local / remote control</td> <td></td> </tr> </tbody> </table> <p>Command signal should be provided by one NC dry contact to terminals 57-3 or terminals 57-4. By switching ON / OFF this contact, is possible to enable or disable the assigned function.</p>	-soft stop	-DC brake	-Linear Ramp	-pump control	-slow speed control	-dual ramp selection	-kick start	-reverse slow speed	-bypass function	-override	-local / remote control	
Terminal	Function																									
57	Common for digital inputs																									
1	Run																									
2	Stop																									
3	Programmable input I3																									
4	Programmable input I4																									
-soft stop	-DC brake	-Linear Ramp																								
-pump control	-slow speed control	-dual ramp selection																								
-kick start	-reverse slow speed	-bypass function																								
-override	-local / remote control																									
Digital Outputs <table border="1"> <thead> <tr> <th>Terminal</th> <th>Function</th> </tr> </thead> <tbody> <tr> <td>11, 12, 14</td> <td>Programmable relay 1r</td> </tr> <tr> <td>23, 24</td> <td>Programmable relay 2r</td> </tr> <tr> <td>33, 34</td> <td>Programmable relay 3r</td> </tr> </tbody> </table>		Terminal	Function	11, 12, 14	Programmable relay 1r	23, 24	Programmable relay 2r	33, 34	Programmable relay 3r	<p>Description 11-12 = NC, 11-14 = N.O. dry contacts. This relay can be assigned to several internal output functions. (p. 3-6) As default assigned to function RUN</p> <p>23-24 = N.O. free voltage contact. This relay can be assigned to several internal output functions. (page 3-6) As default assigned to function EOR</p> <p>33-34 = N.O. free voltage contact. This relay can be assigned to several internal output functions. (page 3-6) As default assigned to function DC BRAKE</p> <p>Common for all relay output contacts</p> <table border="0"> <tbody> <tr> <td>Maximum usage voltage:</td> <td>380VAC</td> </tr> <tr> <td>Thermal current:</td> <td>8A</td> </tr> <tr> <td>AC-15 use:</td> <td>220V / 3A, 380V / 1A</td> </tr> <tr> <td>DC-15 use:</td> <td>30V max/ 3.5A</td> </tr> </tbody> </table>	Maximum usage voltage:	380VAC	Thermal current:	8A	AC-15 use:	220V / 3A, 380V / 1A	DC-15 use:	30V max/ 3.5A								
Terminal	Function																									
11, 12, 14	Programmable relay 1r																									
23, 24	Programmable relay 2r																									
33, 34	Programmable relay 3r																									
Maximum usage voltage:	380VAC																									
Thermal current:	8A																									
AC-15 use:	220V / 3A, 380V / 1A																									
DC-15 use:	30V max/ 3.5A																									
Analog I/O <table border="1"> <thead> <tr> <th>Terminal</th> <th>Function</th> </tr> </thead> <tbody> <tr> <td>8</td> <td>Analog input common</td> </tr> <tr> <td>7</td> <td>TG feedback input</td> </tr> <tr> <td>9</td> <td>Current Output</td> </tr> </tbody> </table>		Terminal	Function	8	Analog input common	7	TG feedback input	9	Current Output	<p>Description This is a common terminal for the analog input terminal number 7.</p> <p>0-5V analog input for speed feedback. It should be provided by a DC tachogenerator coupled to the motor. This speed feedback signal is required when the "linear ramp" function is used.</p> <p>0-10V DC analog Output for current measurement purpose. It correspond to 2V DC Load Impedance 10KΩ or higher</p>																
Terminal	Function																									
8	Analog input common																									
7	TG feedback input																									
9	Current Output																									
Motor thermistor terminals <table border="1"> <thead> <tr> <th>Terminal</th> <th>Function</th> </tr> </thead> <tbody> <tr> <td>5, 6</td> <td>Motor thermistor input</td> </tr> </tbody> </table>		Terminal	Function	5, 6	Motor thermistor input	<p>Description This input allows motor thermistor with response value from 2,8 to 3,2KΩ, and reset value from 0,75 to 1KΩ. When the motor thermistor is not used, a link must be set between those terminals.</p>																				
Terminal	Function																									
5, 6	Motor thermistor input																									
Communications <table border="1"> <thead> <tr> <th>Terminal</th> <th>Function</th> </tr> </thead> <tbody> <tr> <td>SG, TD, RD</td> <td>Gr, Tx, Rx data</td> </tr> </tbody> </table>		Terminal	Function	SG, TD, RD	Gr, Tx, Rx data	<p>Description RS232C, 3 wires, half duplex. Maximum cable length 3mts. Asynchronous data transmission, 9600 Bauds, 1 bit start, 8 bits data, 1 bit stop. no parity</p>																				
Terminal	Function																									
SG, TD, RD	Gr, Tx, Rx data																									

3. Technical specifications

3-3. I/O Wiring

ASTAT Plus's terminal layout and wiring configuration is shown in the diagram of bellow

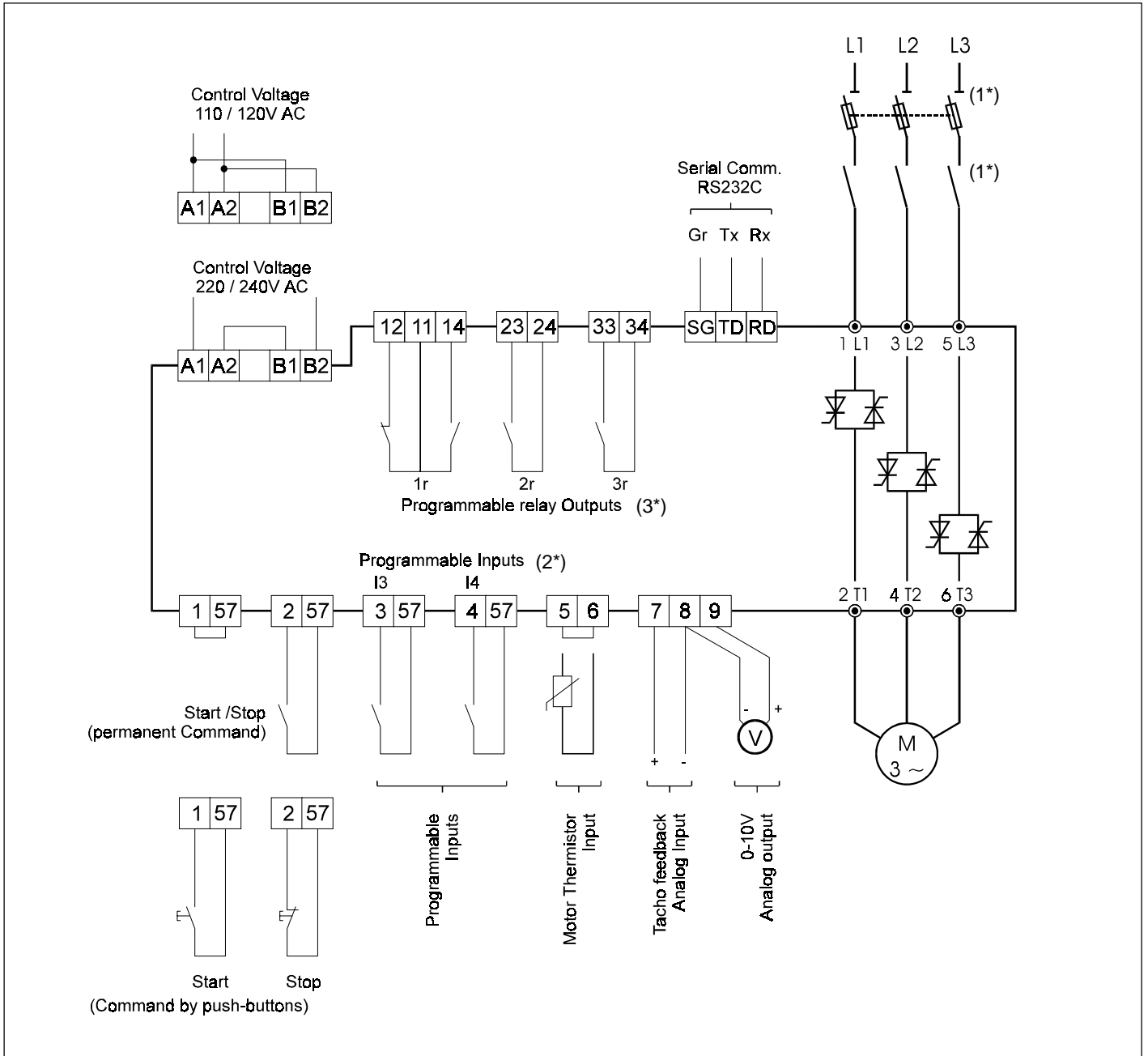

- Notes:**
- (1) Control and Mains wiring recommendations are given in chapter 5.
 - (2) The programmable inputs I3, I4 are not assigned to any function as default. Check pages 3-6 before to use these inputs.
 - (3) The programmable relay outputs are as default assigned to the following functions:
 Relay (1r): RUN, (RUN status)
 Relay (2r): EOR, (End of Ramp)
 Relay (3r): DCBR, (DC Braking control)

3. Technical specifications

3-4. Operating modes

Starting and Stopping

Initial ramp	①	5 main frequency cycles
Initial voltage (pedestal)	①a	30 to 95% U_n (adjustable)
Kick start	②	95% U_n . Enabled by parameter "Pxxx" to ON
Acceleration ramp (t_{ramp})	③	Voltage ramp up from 1 to 99s (adjustable). Dual ramp possibility Linear speed ramp by tacho feedback also possible
	③a	Fast increase of output voltage when motor gets rated speed
Current limit	④	1 to 7 I_n
Permanent state	⑤	Rated voltage (Override)
	⑤a	Rated current
	⑥	Energy savings. Enabled by "Fxxx" to OFF
Stopping modes (All selectable)	⑦	Motor power cut-off. "Sxxx" to OFF, "Cxxx" to OFF
	⑧	Deceleration ramp 1 to 120s (adjustable). Secondary ramp 1 to 99s Ramp down modes available are: - Soft Stop -Voltage ramp down-. Enabled by "Sxxx" to ON - Pump control. Selectable by "Sxxx" to ON and "Cxxx" to ON - Linear ramp down (Tacho feedback needed)
	⑧a	Evolution of current in deceleration ramp mode
	⑨	DC brake (0 to 99s adjustable). Enabled by "Bxxx" to ON

Starting by voltage ramp

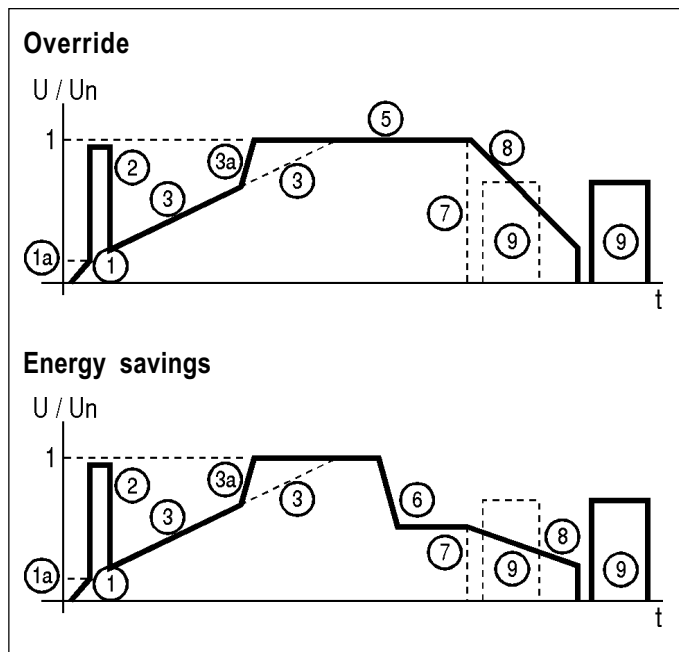

Starting by current limitation

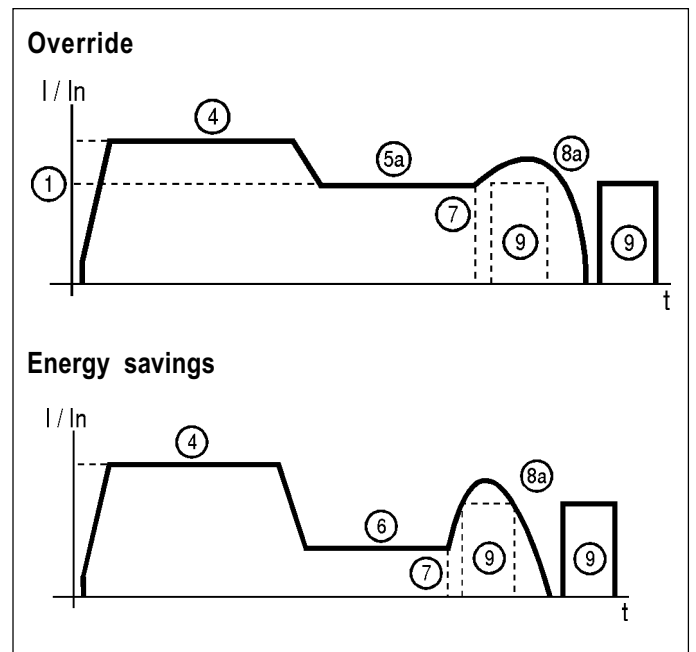

3. Technical specifications

Jog and linear ramp

Linear acceleration and deceleration ramp	① ①a	Ramp time adjustable (Selectable by parameter "Dxxx" to ON)
Low slow (7%) and High slow (14%) speeds	② ③	Enabled by parameter "Jxxx" to ON and "jxxx" to LO or HI
Reverse slow speed (20%)	③a	Enabled by parameter "Jxxx" to ON and "rxxx" to ON
Slow speed (7% or 14%)	④	Enabled by parameter "Jxxx" to ON
Acceleration ramp	⑤	Ramp time adjustable
Soft stop (deceleration ramp)	⑥	Ramp time adjustable
Slow speed (7% or 14%)	⑦	Enabled by parameter "Jxxx" to ON
DC Brake	⑧	Current and time adjustables

Linear ramp with T.G. feedback

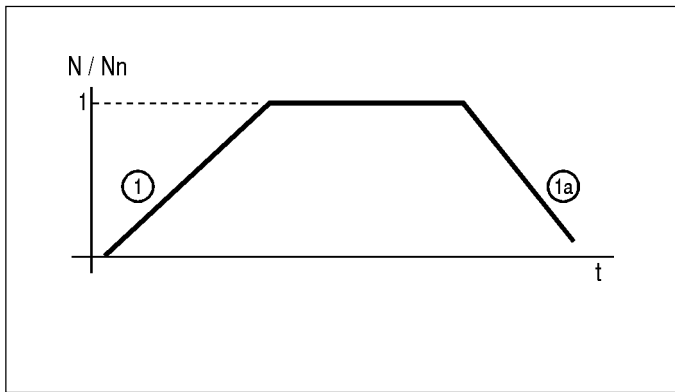

Slow speed. Basic diagram

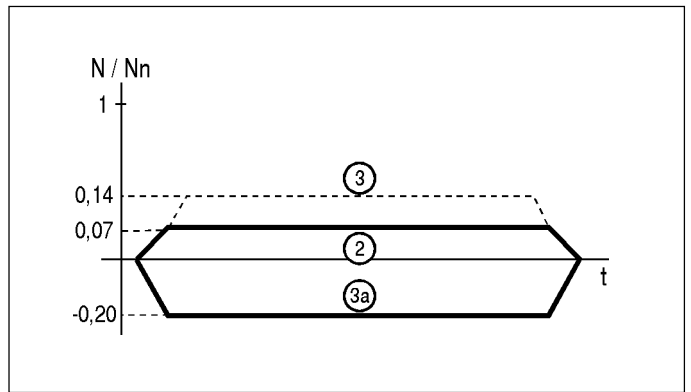

Slow speed. Full diagram

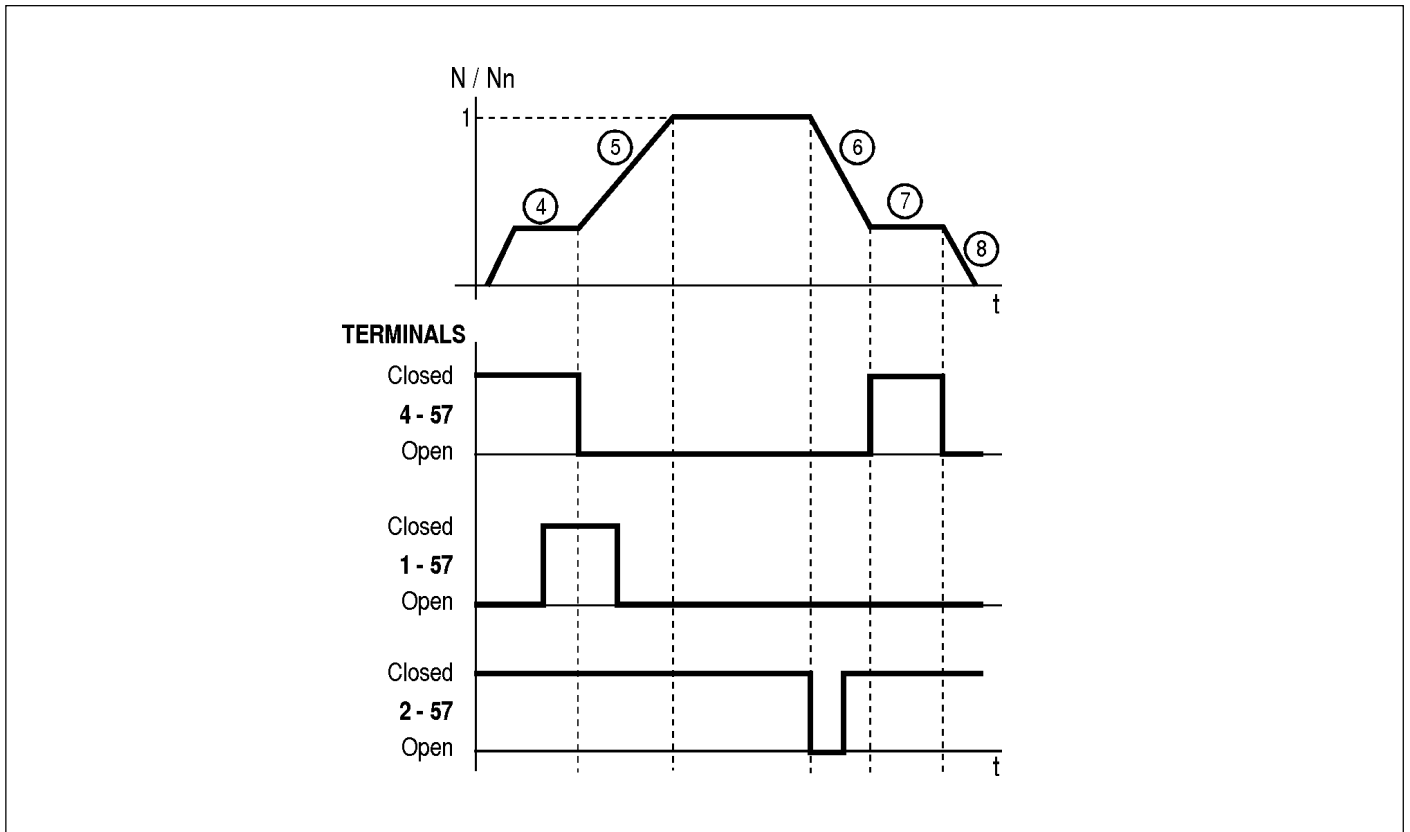

3. Technical specifications

Programmable Inputs and functions

The ASTAT Plus functions like Soft stop, kick start, and almost all others, can be enabled or disabled by setting ON or OFF in their dedicated parameters, using the facilities provided by the keypad. The most of these functions can be enabled or disabled remotely as well, through the programmable inputs I3 or I4 (terminals board 3-57 and 4-57).

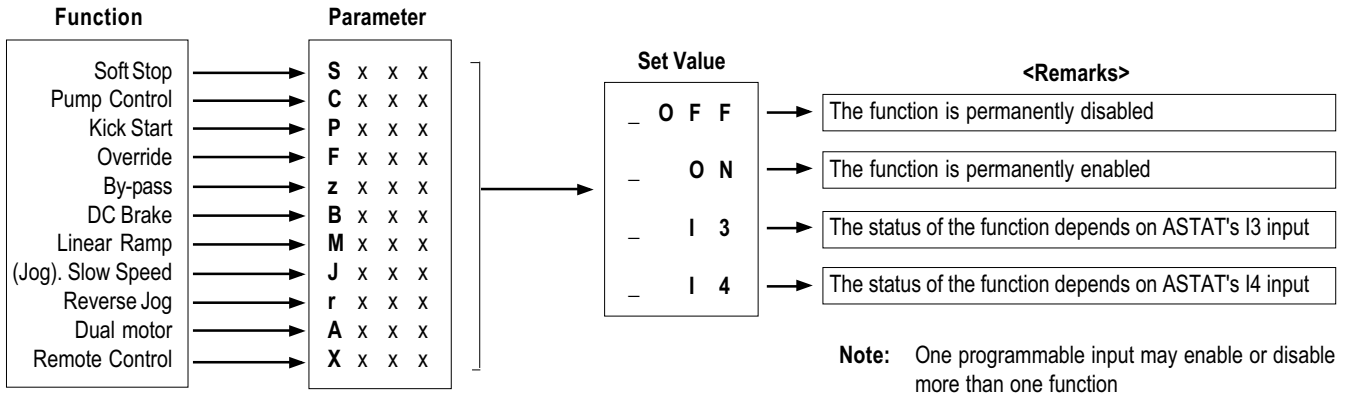

Programmable Relay Outputs

The ASTAT Plus includes three programmable relay named 1r, 2r and 3r, (dry contacts to ASTAT terminals 11-12-14, 23-24 and 33-34) These relays can be assigned to several functions, as shown below

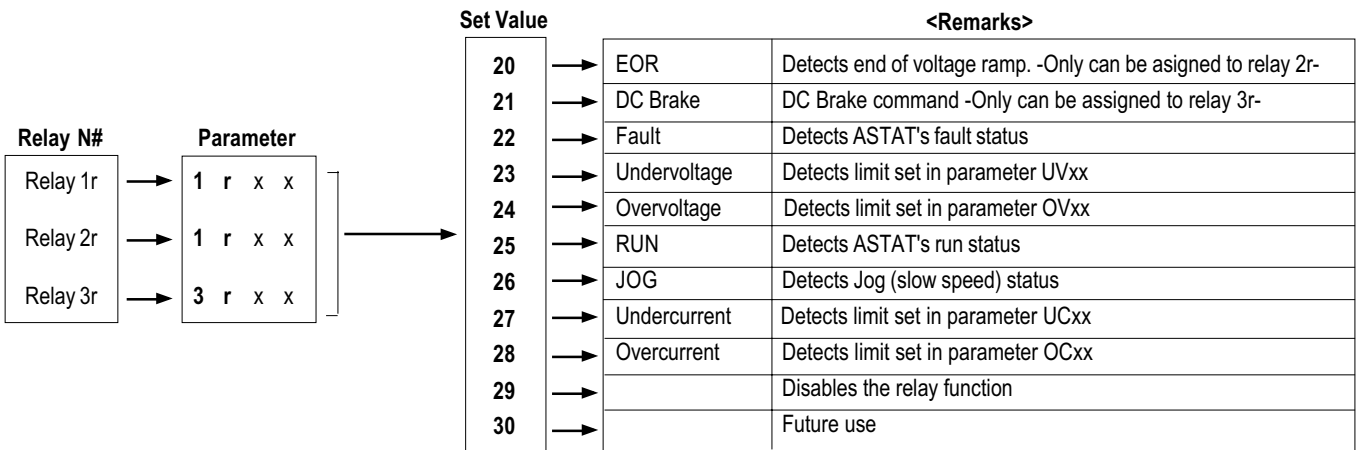

4. Programming

4-1. Keypad and Display description

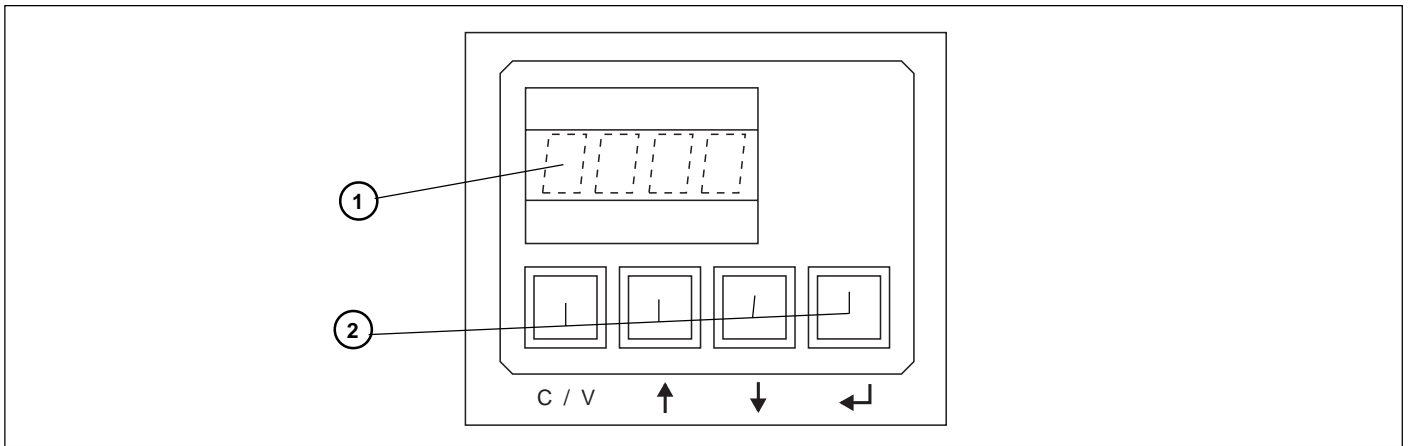

Display ① Displays Monitoring, Status indications, error messages and function set values

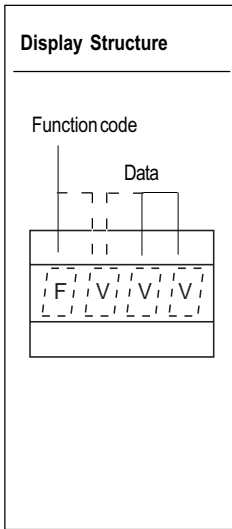

F V V V	Status code
O N	Equipment is connected to main supply (equipment is ON)
S T O P	Stop
L O C K	Remote stop
P U L S	Kickstart
R A M P	Acceleration ramp
F U L L	Full conduction
S A V E	Energy saving
S O F T	Softstop
P U M P	Pump control
D C B K	DC braking
F U L L	Override (full voltage)
I N C H	Inching / slow speed
T A C H	Linear ramp (tacho)

F V V V	Error code
E 0 1 0	Frequency out of range
E 0 1 1	Overload trip
E 0 1 3	Loss of synchronism
E 0 1 4	Phase U scr
E 0 1 5	Phase V scr
E 0 1 6	Phase W scr
E 0 1 7	Heatsink overtemperature
E 0 1 8	Motor thermistor
E 0 1 9	Phase U lost
E 0 2 0	Phase V lost
E 0 2 1	Phase W lost
E 0 2 2	Stalled rotor
E 0 2 3	Internal error
E 0 2 5	Long start time
E 0 2 6	Long slow speed time
E 0 2 7	Lock-out
E 0 2 8	Undervoltage
E 0 2 9	Overvoltage
E 0 3 0	Undercurrent
E 0 3 1	Overcurrent
E 0 3 2	Retry

F F/V V V	function code (*)
M x x x	Motor current
v x x x	Software Version
.	.
P F x x	Power Factor
.	.
L x x x	Limit current
T x x x	Starting Torque
a x x x	Ramp up time
d x x x	Ramp down time
S x x x	Soft Stop selection
.	.
L K x x	Lock out
.	.
.	.

(*) These are examples. Full details in sections 4-2, 4-3, 4-4, 4-5 and 4-6

Keypad ② Allows setting of parameters and functions

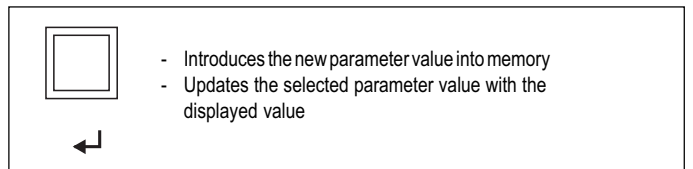
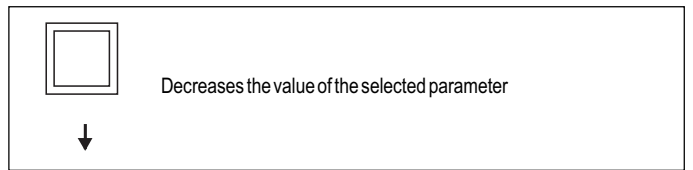
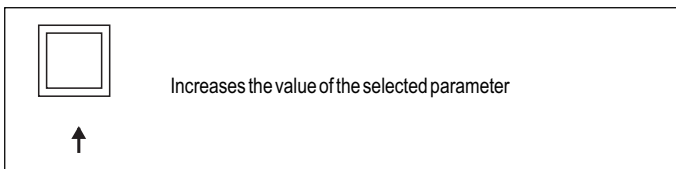
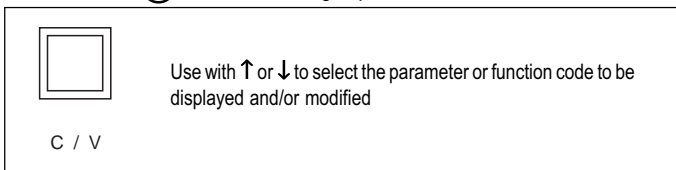

4. Programming

4-2. Parameter Blocks configuration

Mode Selection

The ASTAT Plus includes a large number of parameters which are divided in four blocks: Monitor, Calibration, Basic and Advanced. The parameters of each group can be displayed or skipped according the selection done in parameter "G".

The monitor parameters are always displayed whichever is the mode selected

Settings in parameter "G"	Gxxx	The Monitor parameters are always displayed, whichever are the settings in parameter "G".
	GCAL	The Calibration parameters are displayed
	GBAS	The Basic parameters are displayed
	GADV	The Advanced parameters are displayed
	GALL	All parameters are displayed

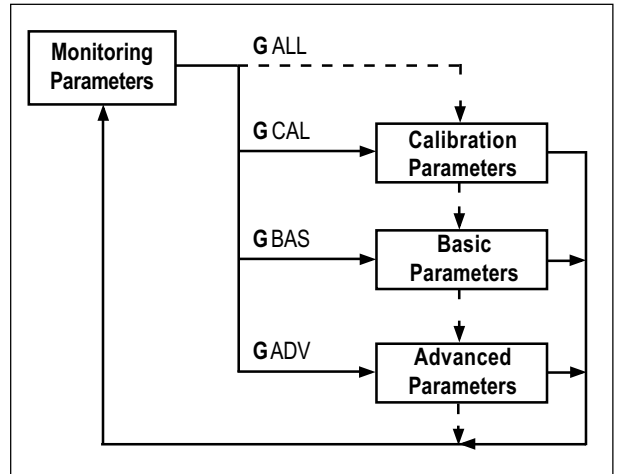

Searching and Setting Parameters

The ASTAT Plus displays the parameters sequentially while maintain pressed key and pushing repeatedly or keys. Proceed in this way until the parameter "G" is displayed.

There is a quick way to search automatically the parameter "G" by pressing and Keys. "Gxxx" will be shown whichever is the actual parameter displayed.

Once the parameter "G" is displayed, choose the value desired by pressing or Keys. The display will sequence "GBAS", "GCAL", "GADV" and "GALL" values repeatedly. The actual value displayed can be stored in a temporal memory buffer by pressing key.

Values stored in the temporal memory are lost after switch off, unless these are saved in the permanent E2PROM memory through parameter "W". Additional indications are given in page 4-4

The above is an example given for parameter "G", but all ASTAT Plus parameters can be modified from its default factory value proceeding in similar way.

Parameter layout

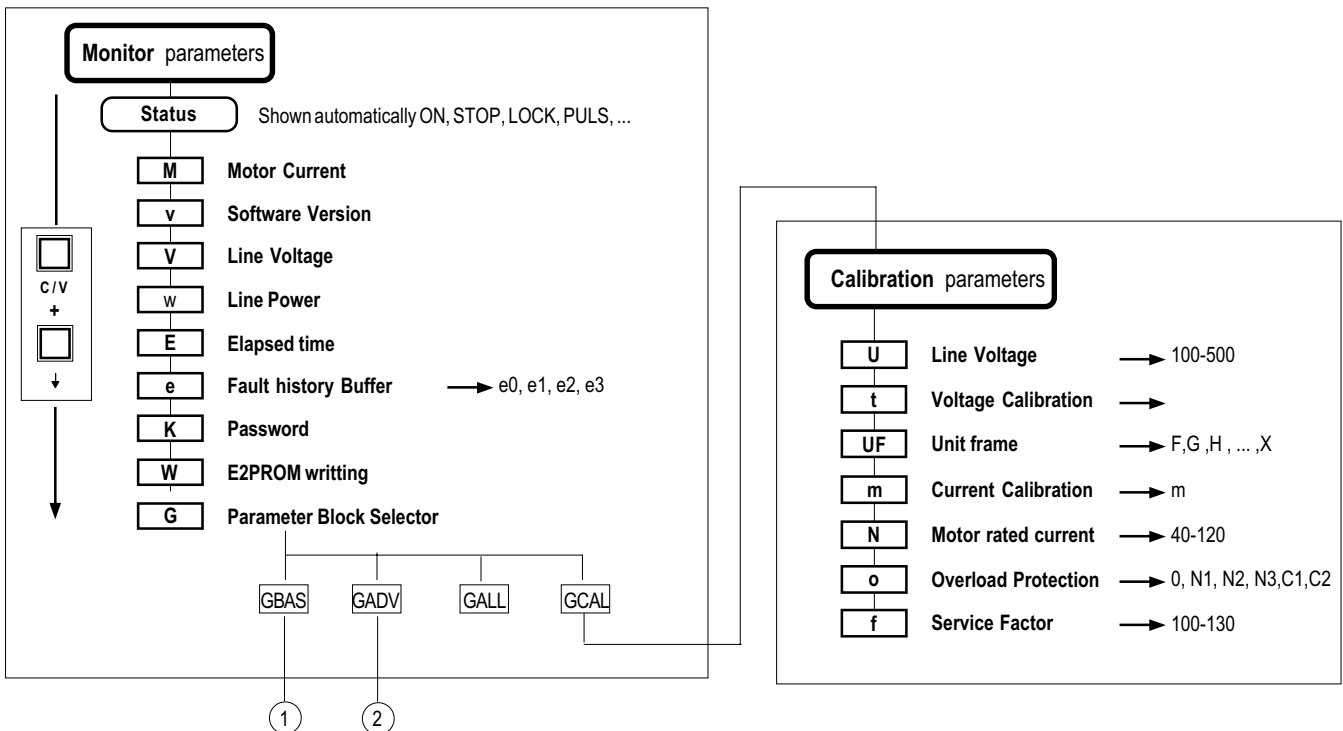

4. Programming

①

Basic Parameters

L	Current Lmit	→ 100-700
T	Starting Torque	→ 010-090
a	Ramp up time	→ 01-99
d	Ramp down time	→ 01-120
p	Kick Start	→ 000-999
b	DC Brake time	→ 000-099
l	DC Brake current	→ 050-250
S	Soft Stop switch	→ OFF, ON, I3, I4
C	Pump Control switch	→ OFF, ON, I3, I4
P	Kick Start Switch	→ OFF, ON, I3, I4
F	Override Switch	→ OFF, ON, I3, I4
z	By-pass Switch	→ OFF, ON, I3, I4
B	DC Brake Switch	→ OFF, ON, I3, I4 PON, PI3, PI4

②

Advanced Parameters

LK	Lock-out	→ 00-45
R	E2PROM Reading	→ ON, OFF
Q	Factory Settings	→ ON, OFF
Y	Retry	→ 000-004
y	Retry time	→ 001-099
UV	Undervoltage	→ 00-50
uv	Undervoltage trip time	→ 00-99
OV	Overvoltage	→ 00-30
ov	Overvoltage trip time	→ 00-99
UC	Undercurrent	→ 00-99
uc	Undercurrent trip time	→ 00-99
OC	Overcurrent	→ 00-50
oc	Overcurrent trip time	→ 00-99
2a	Secondary Ramp up	→ 01-99
2d	Secondary Ramp down	→ 01-99
2t	Secondary Starting Torque	→ 10-90
D	Tacho control switch	→ ON, OFF, I3, I4
J	Slow Speed switch	→ OFF, I3, I4
j	Low / High slow speeds	→ LO, HI
r	Reverse slow speed	→ OFF, ON, I3, I4
A	Dual motor switch	→ OFF, ON, I3, I4
X	Remote control	→ OFF, ON, I3, I4
1r	Output relay 1r	→ 22-30
2r	Output relay 2r	→ 20, 22-30
3r	Output relay 3r	→ 21, 22-30

4. Programming

4-3. Monitor block Parameters

Display	Function	Default	Range	Unit	Description
O N	Status	O N	ON STOP LOCK PULS RAMP FULL SAVE SOFT PUMP DCBK FULL INCH TACH	- - - - - - - - - - - - -	Switch on time. Equipment is connected to main supply Stop Remote stop. Then the control is made thru serial comm. Kick start Acceleration ramp Full conduction Energy saving Soft stop Pump control DC braking Override (full voltage) Inching / slow speed Linear ramp (tacho feedback needed)
M x x x	Motor Current		000-999 1.0-9.9	A kA %	Displays motor current in Amps. Current higher than 999A is displayed in kA If parameter UFxx is not calibrated, the motor current is displayed in %N
v x x x	Software Version		-	-	xxx = Version number
V x x x	Main Source Voltage		-	V	Displays line voltage in Volts.
P F x x	Power Factor		00-99	%	Displays line Power Factor
w x x x	Line Power		-	kW	Displays Line Power
E x x x	Elapsed time		-	Hrs	Displays RUN time in Hours (x 1000)
e x x x	Error trace buffer		e0xx-e3xx	-	Saves the last four errors e0xx: Fault 1 -Latest fault- xx: Fault code error e1xx: Fault 2 e2xx: Fault 3 e3xx: Fault 4
K x x x	Password	K 0 0 0	000-999	-	= 69 allows E2PROM writing operation = 10 Key lock enabled = 20 Key lock disabled
W x x x	E2PROM writting	W O F F	ON, OFF	-	Saves the unit current parameters to the E2PROM This rewrites the last values saved
G x x x	Parameter display selection	G B A S	CAL, BAS, ADV, ALL	-	CAL: Displays Calibration Parameters BAS: Displays Basic Parameters ADV: Displays Advanced Parameters ALL: Displays All parameters
					Note: The Monitor block parameters are always displayed

4. Programming

4-4. Calibration block Parameters -CAL-

Display	Function	Default	Range	Unit	Description
U x x x	Line Voltage setting	U 4 0 0	100-500	V	Line Voltage from 100 to 500V. Set Rated Value
t x x x	Voltage Calibration	t 4 0 0	000-600	V	Setting of this parameter allows better accuracy in monitoring or voltage protections. (Check the current calibration procedure)
U F x	Unit Frame	U F 0	F, G, H, I, J, K, L, M, N, Q, R, ...X	-	Unit frame rating (F,G,H,...X) Setting "0" disables calibration
m x x x	Current Calibration	m 0 0 0	000-1000	A	Setting of this parameter allows better accuracy in monitoring or current protections. (Check the current calibration procedure)
N x x x	Motor Rated Current	N 1 0 0	040-120	%	100 x I motor/ I unit ratio When this parameter is adjusted at a value higher than 105% the overload protection curve is automatically adjusted to Class 10. "C1", or to Nema 20 "N2"
o x x x	Overload Protection	o C 1	OFF N1, N2, N3, C1, C2	-	Selects either the following overload curves OFF: Overload protection disabled (external overload relay must be used) N1: Nema 10 N2: Nema 20 N3: Nema 30 C1: Class 10 C2: Class 20
f x x x	Service Factor	f 1 2 0	100-120	%	Allows motor service factor. Applicable for Nema ratings

(*) Voltage calibration procedure

When the unit is installed on site or after PCB's replacement the voltage measurements may have accuracy of 10%. To improve the Voltage measurement accuracy up to 3% proceed as follow.

1. Switch on the ASTAT and measure the RMS voltage on phases 1L1-3L2 using a calibrated voltmeter
2. Search the parameter "txxx", set the voltage measured and save this value by the enter's keypad key. It is not necessary to rewrite the E2PROM to make permanent the new setting, the ASTAT plus do this automatically.
3. Once the ASTAT has been calibrated, this operation does not need to be repeated. Note however that the parameter "txxx" will show the latest entry, which may differ of actual voltage value.

(*) Current calibration procedure

When the unit is installed on site or after PCB's replacement the current measurements may have accuracy of 10%. To improve the Current measurement accuracy up to 3% proceed as follow.

1. Search parameter "UF x" and enter the right ASTAT's frame type letter. ("F", "G", "H", ..etc.)
2. Start the motor, and measure the rms motor current using a calibrated Ammeter.
This measurement must be done after complete the starting, once the motor current has been stabilized.
3. Search the parameter "mxxx", set the current measured and save this value by the enter's keypad key. It is not necessary to rewrite the E2PROM to make permanent the new setting, the ASTAT Plus do this automatically.
4. Once the ASTAT has been calibrated, this operation does not need to be repeated. Note however that the parameter "mxxx" will show the latest entry, which may differ of actual current value.

4. Programming

4-5. Basic block Parameters. -BAS-

4-5-1. Basic Functions

Display	Function	Default	Range	Unit	Description
L x x x	Current Limit	L 3 5 0	100-700	%	Sets Device current Limit. Sets motor current limit if parameter "N" is properly adjusted. The maximum range setting is automatically calculated by the unit according the following expression: Max Limit = 450 / N (max at all 700%) N is the motor capacity / unit capacity ratio adjusted in parameter "Nxxx".
T x x	Starting Torque	t 2 0	10-90	%	Sets the initial voltage applied to the motor
a x x	Ramp Up time	a 2 0	01-99	sec.	Sets Voltage ramp up time. Motor acceleration time will depend of load conditions.
d x x x	Ramp Down time	d 0 2 0	001-120	sec.	Sets Voltage ramp down time. Motor deceleration time will depend of load conditions. Enabled only if the parameter "Sxxx" is ON
p x x x	Kick start (1)	p 0 0 0	000-999	ms.	During the time adjusted, provides 95% of full voltage to motor at starting time. Useful for high static-friction loads Enabled only if the parameter "Pxxx" is ON
b x x	DC Brake time (1)	b 0 0	00-99	sec.	Provides DC braking at stopping time. Enabled only if the parameter "Bxxx" is ON
I x x x	DC Brake Current (1)	I 0 5 0	050-250	%	

(1) CAUTION If Pump Control is enabled (C=ON), the "Kick Start" and "DC Brake" functions are automatically disabled, so the parameters "p", "b" and "I" are now used to set PID Pump Control algorithm	Function	Display	Description
	Load detection	p x x x	x x x = 0 - 25 (default = 0 in 50Hz P. Source) (default = 15 in 60Hz P. Source)
	Proportional control	b x x x	x x x = 0 - 20 (default = 10)
	Integral time control	I x x x	x x x = 50 - 75 (default = 50)

4-5-2. Programmable Basic Functions

Display	Function	Default	Range	Description
S x x x	Soft Stop selector	S O F F	OFF, ON, I3, I4	Enables or disables all modes of Soft stop
C x x x	Pump Control selector	C O F F	OFF, ON, I3, I4	Enables the Pump control function. It is usefull to limit hammering. The parameter "Sxxx" must be enabled as well.
P x x x	Kick Start selector	P O F F	OFF, ON, I3, I4	Enables or disables the Kckk start function If Pump control function "P" is enabled, both Kick start and DC Brake functions are internally disabled
F x x x	Override selector	F O F F	OFF, ON, I3, I4	Enables or disables the energy saving feature, providing constant full voltage after starting time. Enabling this function the unit produces the lowest harmonic contents

4. Programming

Programmable Basic Functions (follow from previous page)

z x x x	By-pass selector	z 0 F F	OFF, ON, I3, I4	This function provides control of an external by-pass contactor, avoiding unit losses and harmonics When the By-Pass function "z" is enabled, the programmable relay output 2r is automatically assigned to this function, and must be used to control the external by-pass contactor
B x x x	DC Brake selector	B 0 F F	OFF, ON, I3, I4, PON, PI3, PI4	Enables or disables the DC brake function When the DC Brake function "B" is enabled, the programmable relay output 3r is automatically assigned to this function. PON, PI3 or PI4 settings enable the DC Brake function just before to start the motor. This is useful to stop a fan which is rotating in reverse at the starting time

4-6. Advanced Block Parameters -ADV-

4-6-1. Advanced Functions

Display	Function	Default	Range	Unit	Description
L K x x	Lock-Out	L K 0 0	00-45	min.	Sets time between consecutive starts. Setting "0" disables this function.
R x x x	E2PROM reading	R 0 F F	ON, OFF	-	Load the parameters from the E2PROM to the temporal buffer
Q x x x	Factory settings	Q 0 F F	ON, OFF	-	Load default factory settings to the temporal buffer.
Y x	Retry	Y 0	0-4	-	Allows up to four tries of automatic restart after a fault. Setting "0" disables this function.
y x x	Retry time	y 1 0	01-99	sec.	Time between retries.
U V x x	Undervoltage	U V 0 0	00-50	%	The unit trips if the line voltage decreases below of the percentage set. Setting "0" disables this protection. Note: Calibrate parameter "U" before to enable this protection.
u v x x	Undervoltage trip time	u v 2 0	00-99	sec.	Delay trip time
O V x x	Overvoltage	O V 0 0	00-30	%	The unit trips if the line voltage increases above of the percentage set. Setting "0" disables this protection. Note: Calibrate parameter "U" before to enable this protection.
o v x x	Overvoltage trip time	o v 2 0	00-99	sec.	Delay trip time
U C x x	Undercurrent	U C 0 0	00-99	%	The unit trips if the current decreases below of the percentage set. Setting "0" disables this protection. Note: Calibrate parameter "U" before to enable this protection.
u c x x	Undercurrent trip time	u c 2 0	00-99	sec.	Delay trip time
O C x x	Overcurrent	O C 0 0	00-50	%	The unit trips if the current increases above of the percentage set. Setting "0" disables this protection. Note: Calibrate parameter "U" before to enable this protection.
o c x x	Overcurrent trip time	o c 2 0	00-99	sec.	Delay trip time.
2 a x x	Dual Ramp Up	2 a 2 0	01-99	%	These are a secondary set of ramp up, ramp down and starting torque parameters, which take over the primary "a", "d" and "T" when the programmable function "A" is enabled.
2 d x x	Dual Ramp Down	2 d 2 0	01-99	%	
2 T x x	Dual Starting Torque	2 T 2 0	10-90	%	

4. Programming

4-6-2. Programmable Advanced Functions

Display	Function	Default	Range	Description
D x x x	Linear Ramp	D O F F	OFF, ON, I3, I4	This function provides linear acceleration and deceleration ramps in a wider range of load conditions. A DC Tacho-Generator coupled to motor must be used to provide an analog signal feedback of 0-5VDC
J x x x	Slow Speed	J O F F	OFF, I3, I4	This function allows slow speed operation Maximum operation time 120sec.
j x x	Speed changeover	j L O	LO, HI	LO: Low Speed, 7% of rated speed. HI: High Speed, 14% of rated speed.
r x x x	Reverse	r O F F	OFF, ON, I3, I4	Reverse direction is allowed in "High slow speed" mode only. It provides 20% of rated speed
A x x x	Dual motor selector	A O F F	OFF, ON, I3, I4	This function allows dual motor control settings of acceleration, deceleration and starting torque, and is useful to start or stop a motor in different load conditions. When this function is enabled, the parameters 2a, 2d and 2T take over the parameters a, d and T. It allows dual motor control settings
X x x x	Remote control selector	X O F F	OFF, ON, I3, I4	Allows serial communication control by SG, TD and RD terminals. Check Appendix section for more details

4-6-3. Programmable Relay Output Functions

Display	Function	Default	Range	Description
1 r x x	Output relay 1r	1 r 2 5	22-30	This is a programmable relay with one NO / NC dry contacts to ASTAT Plus's terminals 11-12-13
2 r x x	Output relay 2r	2 r 2 0	20, 22-30	This is a programmable relay with one NO dry contact to ASTAT Plus's terminals 23-24 This relay is automatically assigned to BY-Pass control if the function "z" is ON. Any other assignment by the user is overwritten in this case
3 r x x	Output relay 3r	3 r 2 1	21, 22-30	This is a programmable relay with one NO dry contact to ASTAT Plus's terminals 33-34 This relay is automatically assigned to DC-Brake control if the function "B" is ON. Any other assignment by the user is overwritten in this case

The programmable relays can be set to the functions shown in the following table

Range	Function	Remarks
20	EOR	Detects end of voltage ramp. -This function only can be assigned to relay 2r-
21	DC Brake	DC Brake control command -This function only can be assigned to relay 3r-
22	FAULT	Detects unit Fault status
23	Undervoltage	Detects Undervoltage according limit adjusted in function "UV"
24	Overvoltage	Detects Overvoltage according limit adjusted in function "OV"
25	RUN	Detects unit RUN status
26	Slow Speed	Detects slow speed status
27	Undercurrent	Detects Undercurrent according limit adjusted in function "UC"
28	Overcurrent	Detects Overcurrent limits as adjusted in function "OC"
29	Disabled	Disables the relay function
30	Future use	

5. Installation

5-1. Equipment installation

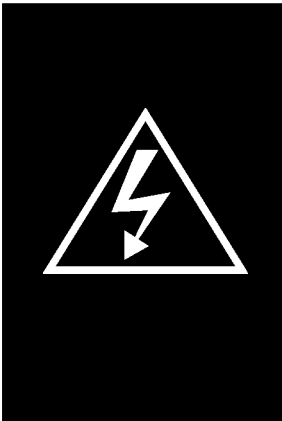

CAUTION! DISCONNECT POWER BEFORE INSTALLING OR SERVICING

ONLY SPECIALIZED PERSONNEL SHOULD INSTALL THE EQUIPMENT AND ONLY AFTER HAVING READ THIS USER'S GUIDE.

THE USER ITSELF IS RESPONSIBLE FOR ANY PHYSICAL INJURY OR MATERIAL DAMAGE RESULTING FROM MISHANDLING THE EQUIPMENT.

IF YOU HAVE ANY DOUBTS ABOUT ANY PROCEDURE, PLEASE CONTACT YOUR DEALER.

Remarks

Supply wire conductors should have the same section as direct starters. As an indication, **Vd** voltage drop in wires should not be more than 2%.

$$Vd = \frac{\sqrt{3} \times R \times L \times I_n}{1000}$$

R = conductor resistance (mΩ / m)
L = conductor length (m)
I_n = motor rated current (A)

Conductor section (mm ²)	2,5	4	6	10	16	25	35	50	100	150
Resistance R (Cu) 20°C (mΩ / m)	7,5	4,55	3,05	1,85	1,13	0,725	0,528	0,254	0,183	0,122
Resistance R (Al) 20°C (mΩ / m)					1,86	1,188	0,868	0,416	0,3	0,2

Signal wiring should be no longer than 50cm, and should be separate from power wires (line, motor, command relays, etc.) by at least 10cm, and if they cross, they should do so at a 90° angle

Relays and contactors located in the same housing as the equipment should have an RC suppressor parallel to the coil (or a reverse diode, if controlled by DC).

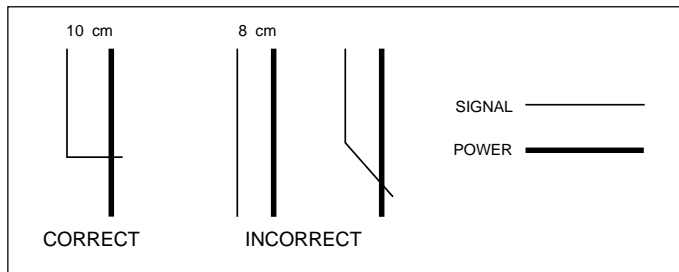

Do not install capacitors to correct the power factor between equipment output and motor

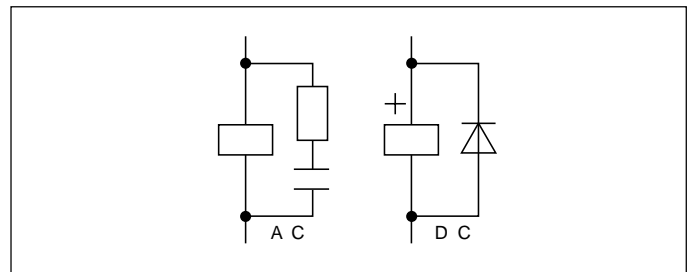

If the equipment is fed by a line transformer, its rated power should be at least 1.5 times, but less than 10 times, higher than equipment supply.

Environment

When installing equipment, keep the following points in mind :

- The equipment should be installed vertically and hang over a platform or bars. The vertical position is essential for proper cool air circulation
- Environmental conditions are in accordance with the following ranges and maximum values :
 - Operating temperature : 0°C to +55°C
 - Relative humidity (without condensation) : 95%
 - Maximum altitude : 3000m
- Reduce usage intensity by 1.5% / °C from 40°C and 1% / 100m from 1000m
- Do not install equipment in environments containing explosive or flammable gases, or near important heat sources
- Equipment should be well ventilated, at least keeping clearances as indicated in the following illustration.
- When equipment is to be mounted on a platform subject to strong vibrations, there should be an elastic base to protect the equipment.

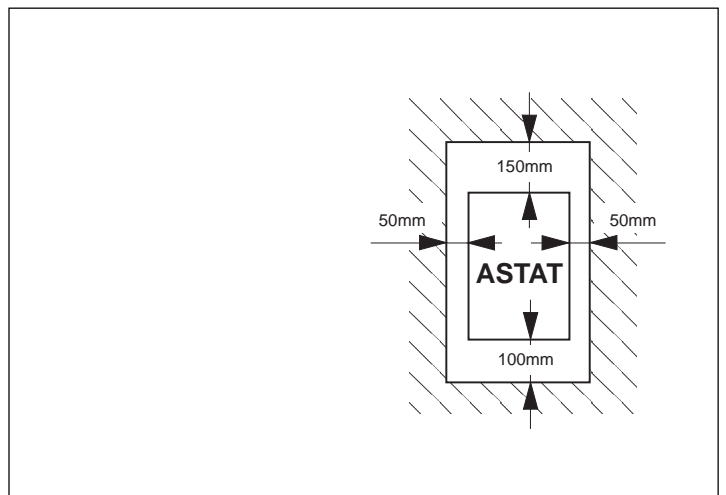

5. Installation

5-2. Fuses, contactors and supply wiring

IEC Class 10 Ratings

TYPE	In A	Total losses 100% In W	Fuses aM (F1) A	Fuses FERRAZ type (XX=according mech. design)	Fuses BUSSMANN type (Typower Sicu 660V~)		Control voltage		Contactor DC 1	Contactor DC 3 (2)	Conductor section mm ²
					Size	In	Fuse A	Consumpt. VA			
QC _ F DP	17	67	25	6,600 CP URC 14.51/40	00	40	1	18	CL02	CL02	4
QC _ G DP	21	78	32	6,6 URD 30 XX 0063	00	50	1	18	CL03	CL03	4
QC _ H DP	27	88	40	6,6 URD 30 XX 0080	00	80	1	18	CL04	CL03	6
QC _ I DP	38	116	63	6,6 URD 30 XX 0100	00	100	1	18	CL45	CL04	10
QC _ J DP	58	208	80	6,6 URD 30 XX 0125	00	125	2	55	CL07	CL45	16
QC _ K DP	75	277	100	6,6 URD 30 XX 0160	00	160	2	55	CL08	CL06	25
QC _ L DP	86	302	125	6,6 URD 30 XX 0160	00	200	2	55	CL09	CL06	35
QC _ M DP	126	389	200	6,6 URD 30 XX 0250	00	250	2	55	CL75	CL07	50
QC _ N DP	187	719	250	6,6 URD 30 XX 0315	00	315	2	78	CK08	CL10	95
QC _ Q DP	288	1097	400	6,6 URD 31 XX 0500	2	550	2	78	CK95	CK85	185
QC _ R DP	378	1286	500	6,6 URD 31 XX 0630	2	630	4	118	CK10	CK85	240
QC _ S DP	444	1374	630	6,6 URD 32 XX 0800	2	800	4	118	CK11	CK95	Bus bar (1)
QC _ T DP	570	2086	800	6,6 URD 33 XX 1000	3	1000	4	118	CK12	CK10	Bus bar (1)
QC _ U DP	732	2352	1000	6,6 URD 33 XX 1250	3	1250	4	248	CK12	CK10	Bus bar (1)
QC _ V DP	1020	3000	1250	6,6 URD 233 XX 2000	-	-	4	248	CK13	CK11	Bus bar (1)
QC _ X DP	1290	3839	2x800	6,6 URD 233 XX 2000	-	-	4	248	CK13	CK12	Bus bar (1)

(1) As per IEC 947

(2) The 3 contacts of DC3 must be connected in parallel

IEC Class 20 Ratings

TYPE	In A	Total losses 100% In W	Fuses aM (F1) A	Fuses FERRAZ type (XX=according mech. design)	Fuses BUSSMANN type (Typower Sicu 660V~)		Control voltage		Contactor DC 1	Contactor DC 3 (2)	Conductor section mm ²
					Size	In	Fuse A	Consumpt. VA			
QC _ F DP	14	56	20	6,600 CP URC 14.51/40	00	40	1	18	CL01	CL01	4
QC _ G DP	17	65	25	6,6 URD 30 XX 0063	00	50	1	18	CL02	CL02	4
QC _ H DP	22	74	32	6,6 URD 30 XX 0080	00	80	1	18	CL03	CL03	4
QC _ I DP	32	99	63	6,6 URD 30 XX 0100	00	100	1	18	CL04	CL04	6
QC _ J DP	48	178	80	6,6 URD 30 XX 0125	00	125	2	55	CL06	CL04	10
QC _ K DP	63	236	80	6,6 URD 30 XX 0160	00	160	2	55	CL07	CL04	16
QC _ L DP	72	257	100	6,6 URD 30 XX 0160	00	200	2	55	CL08	CL06	25
QC _ M DP	105	325	160	6,6 URD 30 XX 0250	00	250	2	55	CL10	CL06	35
QC _ N DP	156	591	200	6,6 URD 30 XX 0315	00	315	2	78	CK75	CL07	70
QC _ Q DP	240	901	315	6,6 URD 31 XX 0500	2	550	2	78	CK85	CK75	120
QC _ R DP	315	1063	400	6,6 URD 31 XX 0630	2	630	4	118	CK95	CK85	185
QC _ S DP	370	1136	500	6,6 URD 32 XX 0800	2	800	4	118	CK10	CK85	240
QC _ T DP	475	1721	630	6,6 URD 33 XX 1000	3	1000	4	118	CK11	CK95	Bus bar (1)
QC _ U DP	610	1950	800	6,6 URD 33 XX 1250	3	1250	4	248	CK12	CK10	Bus bar (1)
QC _ V DP	850	2491	1000	6,6 URD 233 XX 2000	-	-	4	248	CK13	CK10	Bus bar (1)
QC _ X DP	1075	3168	1250	6,6 URD 233 XX 2000	-	-	4	248	CK13	CK12	Bus bar (1)

(1) As per IEC 947

(2) The 3 contacts of DC3 must be connected in parallel

5. Installation

5-3. Start-up

<ul style="list-style-type: none"> - Make sure equipment wiring corresponds to one of the recommended routing diagrams or equivalent 	<ul style="list-style-type: none"> - If the motor does not have thermal protection sensor, a link must be set between terminals 5 and 6 															
<ul style="list-style-type: none"> - Make sure the control wire harness corresponds to the control voltage used. 	<div style="display: flex; justify-content: space-around;"> <div style="text-align: center;"> <p>110/120V ac</p> </div> <div style="text-align: center;"> <p>220/240V ac</p> </div> </div>															
<ul style="list-style-type: none"> - Adapt equipment rated current to motor, setting the motor current In 	$N \ x \ x \ x ; \ x \ x \ x = \frac{I_n \text{ (motor)}}{I_r \text{ (unit)}} \times 100$ <p style="text-align: right;">Factory setting N 1 0 0</p>															
<ul style="list-style-type: none"> - Set overload trip curve as needed 	<p>oxxx; xx x OFF = disabled (external overload relay must be used) C1/C2 = IEC Class 10 or Class 20 N1/N2/N3= Nema 10, 20 or 30</p> <p style="text-align: right;">Factory setting o C1</p>															
<ul style="list-style-type: none"> - Set starting parameters as needed : $L \ x \ x \ x = \frac{I_m \text{ (start)}}{I_n \text{ (motor)}} \times 100$	<table style="width: 100%; border-collapse: collapse;"> <tr> <td style="width: 40%;">Starting torque</td> <td style="width: 20%;">T _ x x</td> <td style="width: 40%; text-align: right;">T _ 20</td> </tr> <tr> <td>Acceleration ramp time</td> <td>a x x x</td> <td style="text-align: right;">a _ 20</td> </tr> <tr> <td>Kickstart</td> <td>P ON/OFF/I3/I4</td> <td style="text-align: right;">P OFF</td> </tr> <tr> <td>Kickstart time</td> <td>p x x x (if P enabled)</td> <td style="text-align: right;">P 1 0 0</td> </tr> <tr> <td>Current limit</td> <td>L x x x</td> <td style="text-align: right;">L 3 0 0</td> </tr> </table> <p style="text-align: right;">Factory setting</p>	Starting torque	T _ x x	T _ 20	Acceleration ramp time	a x x x	a _ 20	Kickstart	P ON/OFF/I3/I4	P OFF	Kickstart time	p x x x (if P enabled)	P 1 0 0	Current limit	L x x x	L 3 0 0
Starting torque	T _ x x	T _ 20														
Acceleration ramp time	a x x x	a _ 20														
Kickstart	P ON/OFF/I3/I4	P OFF														
Kickstart time	p x x x (if P enabled)	P 1 0 0														
Current limit	L x x x	L 3 0 0														
<ul style="list-style-type: none"> - Set braking parameters as needed : 	<table style="width: 100%; border-collapse: collapse;"> <tr> <td style="width: 40%;">Soft stop</td> <td style="width: 20%;">S ON/OFF/I3/I4</td> <td style="width: 40%; text-align: right;">S OFF</td> </tr> <tr> <td>Deceleration ramp time</td> <td>d x x x</td> <td style="text-align: right;">d _ 20</td> </tr> <tr> <td>DC injection brake</td> <td>B ON/OFF/I3/I4</td> <td style="text-align: right;">B OFF</td> </tr> <tr> <td>DC braking time</td> <td>b _ x x (if B enabled)</td> <td style="text-align: right;">b _ _ 5</td> </tr> <tr> <td>DC braking current</td> <td>l x x x (if B enabled)</td> <td style="text-align: right;">l 1 5 0</td> </tr> </table> <p style="text-align: right;">Factory setting</p>	Soft stop	S ON/OFF/I3/I4	S OFF	Deceleration ramp time	d x x x	d _ 20	DC injection brake	B ON/OFF/I3/I4	B OFF	DC braking time	b _ x x (if B enabled)	b _ _ 5	DC braking current	l x x x (if B enabled)	l 1 5 0
Soft stop	S ON/OFF/I3/I4	S OFF														
Deceleration ramp time	d x x x	d _ 20														
DC injection brake	B ON/OFF/I3/I4	B OFF														
DC braking time	b _ x x (if B enabled)	b _ _ 5														
DC braking current	l x x x (if B enabled)	l 1 5 0														
<p>If do you change the default configuration and wish to keep it, remember to rewrite the parameters in E2PROM as follows :</p>	<ul style="list-style-type: none"> - Set parameter K to ON (ON = 69 + ←↓) - Set parameter W to ON - Press ←↓ (parameter W is set to OFF automatically) 															
<ul style="list-style-type: none"> - Send run command to equipment and make sure that operation is correct. 																

5-4. Troubleshooting

Symptom or Error	Possible Cause	Measures to be taken
Display OFF	No control voltage	Check wire harness and control voltage
	F1 fuse blown on power supply PCB	Check and change
	Bad connection of flat wire joining power supply PCB to control PCB	Verify connectors
Equipment does not respond to STOP / START controls	F2 fuse blown on power supply PCB	Check and change
Frequency error (admits 45Hz ≤ f main ≤ 65Hz)	No 1L1 phase or frequency is out of range	Check 1L1 phase and/or mains frequency
Overload trip	Excessive load or excessive current during starting	Verify overload conditions during starting time and steady state. Check settings in parameters "Nxxx", "Lxxx", and "oxxx"

5. Installation

Symptom or Error	Possible Cause	Measures to be taken
Synchronism loss	Phase 1L1 lost	Check 1L1 phase
Phase U, V, W thyristor	Shortcircuited thyristor	Check thyristor module
	No output phases	Check 2T1, 4T2 and 6T3 phases
Heatsink thermostat	Heatsink thermostat tripped by overheating or defective	Check thermostat and wiring
Motor thermistor	Motor thermistor tripped by overheating or defective	Check thermistor and wiring
Phase U, V, W loss	No input / output phases	Check power wire harness for 1L1, 3L2, 5L3, 2T1, 4T2 and 6T3
	Defective thyristor or bad wire harness	Verify gate and cathode wire harness. Verify thyristors
Stalled rotor	Equipment detected stalled motor rotor	Restart equipment and check for an appreciable loss in motor speed at any time (i.e. when the motor is loaded). In this case, try jumping the bypass terminals 3-57 at the end of acceleration ramp).
Internal error	Microcontroller malfunction	Check IC1 and IC8 are correctly inserted in their sockets
Long start time	Current limit condition present more than 2 x ta sec. or 240 sec. (ta = acceleration ramp time)	Increase current limit and / or acceleration ramp time
Long slow speed time	Equipment has been in slow speed mode more than 120 sec.	Avoid this condition
Lock-out	The time between startings is less that the adjusted in parameter "LKxx"	Check is settings are correct This protection may be disabled
Undervoltage Overvoltage	The line voltage exceeds of limit set in parameters "UVxx" or "OVxx"	Check is settings are correct. This protection may be disabled
Undercurrent Overcurrent	The motor current exceeds of limit set in parameters "UCxx" or "OCxx"	Check is settings are correct. This protection may be disabled
Retry	The retry feature could not re-start the motor after a fault	Check last message "e1xx" and correct. Be sure that retry settings are correct as well.

5-5. Thyristor check

Shortcircuit

Use a testing lamp to check the defective power module between input and output phases.
If the lamp goes on, at least one of the thyristors has a shorcircuit.
Check with a tester the value or the R resistance between input and output of the same phase (connector B on main PCB must be previously removed)
If $R < 50K\Omega$, at least one of the thyristor is defective

Open thyristor

With the simple assembling shown here, the lamp should light when the S switch is closed and remain lighting when open.
If not, the thyristor is defective.

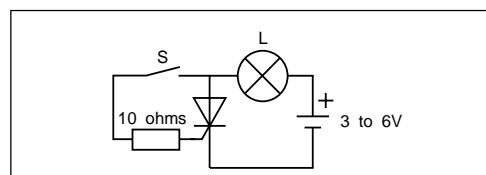
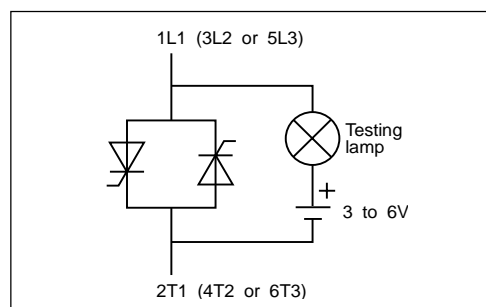

6. Appendix

6-1. Application diagrams

Basic diagram

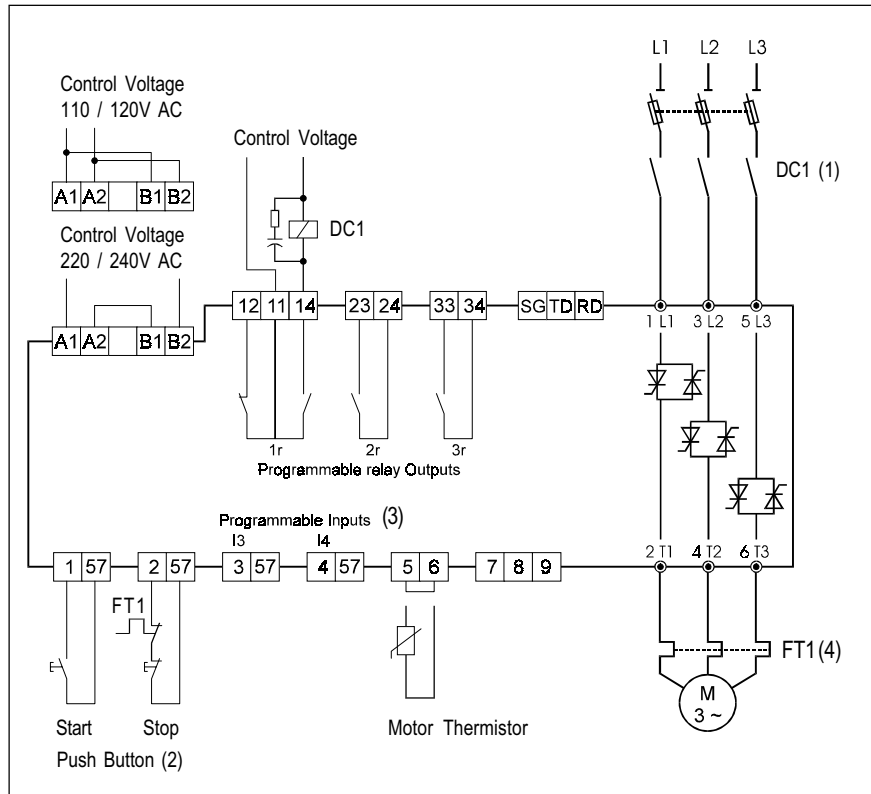

REMARKS:

- (1) The line contactor DC1, is not required to perform operation to the motor. Be aware however that DC1 provides galvanic isolation from the mains increasing the safety.
- (2) In this example, Start and Stop command is effected by push-buttons. Permanent command is allowed as well, wiring 1, 2 and 57 terminals as shown in page 3-3.
- (3) The output relays allow for direct action on contactors according ratings specified in page 3-2 of this manual.
- (4) The ASTAT Plus is performed with an electronic motor overload protection, which may be enough in the most of the applications. You should use an external overload protection if required by local rules or to protect the motor against current unbalance.

Basic diagram with By-Pass control

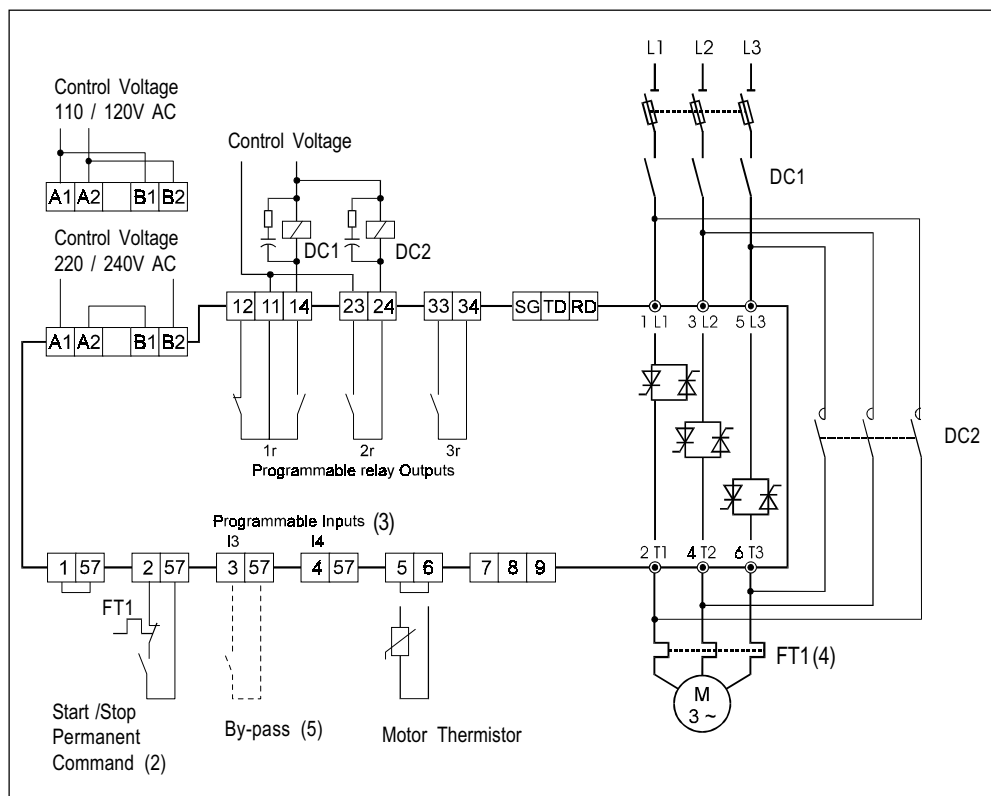

REMARKS:

- (1) The line contactor DC1, is not required to perform operation to the motor. Be aware however that DC1 provides galvanic isolation from the mains increasing the safety.
- (2) In this example, Start and Stop command is effected by permanent command. Push-buttons control is allowed as well, wiring 1, 2 and 57 terminals as shown in page 3-3.
- (3) The output relays allow for direct action on contactors according ratings specified in page 3-2 of this manual.
- (4) CAUTION: In by-pass mode an external overload relay protection must be used.
- (5) By-pass control using function "zxxx" and external contactor DC2. Details given below.

By-pass control. Programming steps

1. The by-pass function may be enabled by setting "zxxx" to ON. In this case the by-pass is automatically done after starting. As alternative, if "zxxx" is set to one of the programmable inputs "I3" or "I4", the by-pass may be controlled by one remote signal (5). Check section 4-5-2 for more details.
2. Once this function is enabled, the relay 2r is automatically assigned to this function (check section 4-6-3). This relay must be used to control the by-pass contactor.

6. Appendix

6-1. Application diagrams

Basic diagram with jog (slow speed) function

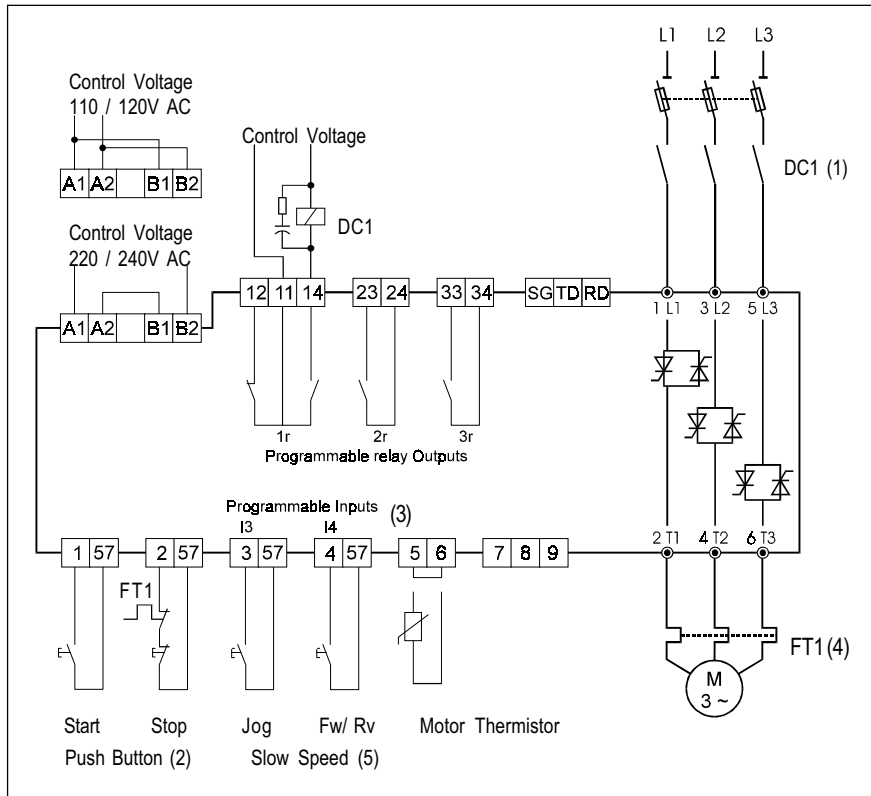

REMARKS:

- (1) The line contactor DC1, is not required to perform operation to the motor. Be aware however that DC1 provides galvanic isolation from the mains increasing the safety.
- (2) In this example, Start and Stop command is effected by push-buttons. Permanent command is allowed as well, wiring 1, 2 and 57 terminals as shown in page 3-3.
- (3) The output relays allow for direct action on contactors according ratings specified in page 3-2 of this manual.
- (4) The ASTAT Plus is performed with an electronic motor overload protection, which may be enough in the most of the applications. You should use an external overload protection if required by local rules or to protect the motor against current imbalance.
- (5) Slow Speed for Jog forward or reverse using programmable inputs I3, I4. Details given below.

Jog (Slow Speed) function. Programming steps

1. The slow speed function may be enabled by setting "Jxxx" to I3. In this case Slow Speed is allowed by a push-button wired to ASTAT's Plus terminals 3-57. Reverse jog is also possible by setting "rxxx" to ON. As alternative, if "rxxx" is set to programmable input I4, forward or reverse may be controlled by remote push-button signal (5). Check section 4-6-3 for more details.
2. Slow Speed can be effected with ASTAT Plus in stop status. Slow speed and normal run commands are internally interlocked.

Basic diagram with DC brake injection

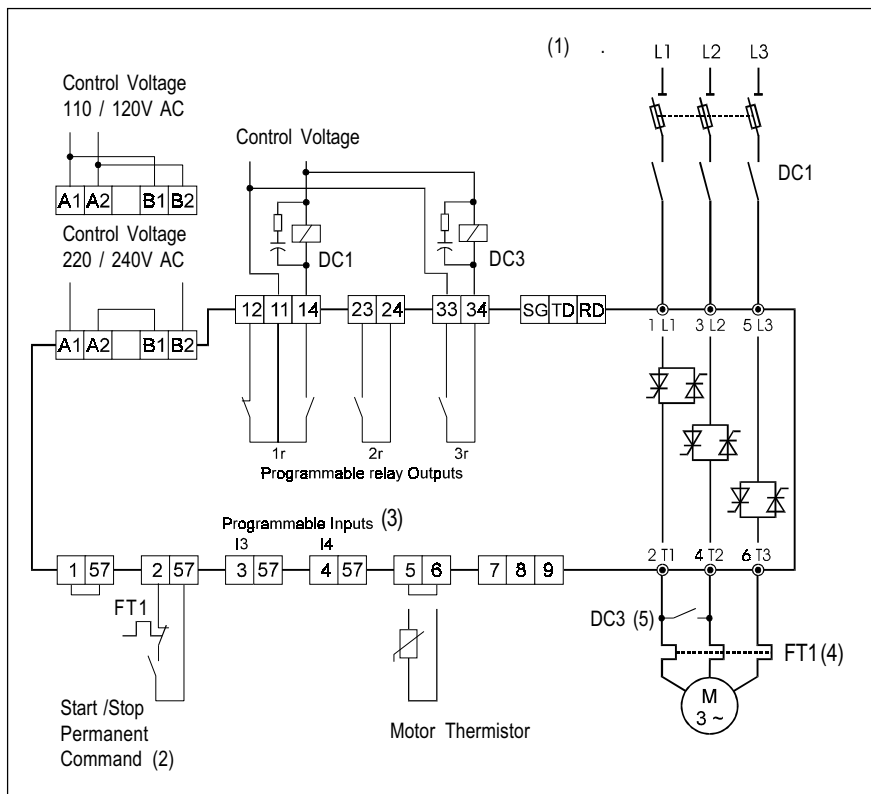

REMARKS:

- (1) The line contactor DC1, is not required to perform operation to the motor. Be aware however that DC1 provides galvanic isolation from the mains increasing the safety.
- (2) In this example, Start and Stop command is effected by permanent command. Push-buttons control is allowed as well, wiring 1, 2 and 57 terminals as shown in page 3-3.
- (3) The output relays allow for direct action on contactors according ratings specified in page 3-2 of this manual.
- (4) The ASTAT Plus is performed with an electronic motor overload protection, which may be enough in the most of the applications. You should use an external overload protection if required by local rules or to protect the motor against current imbalance.
- (5) DC brake at stopping time is provided by the DC brake function and external contactor DC3.

CAUTION:

The 3 contacts of DC3 must be connected in parallel. Mandatory between 2T1 and 4T2 phases, otherwise a short-circuit can occur

DC brake function. Programming steps

1. The DC function may be enabled by setting "Bxxx" to ON.
2. Once this function is enabled, the relay 3r is automatically assigned to this function. This relay must be used to control the DC brake contactor.

Check section 4-5-1 and 4-5-2 for more details

6. Appendix

6-1. Application diagrams

Basic diagram with Linear ramp

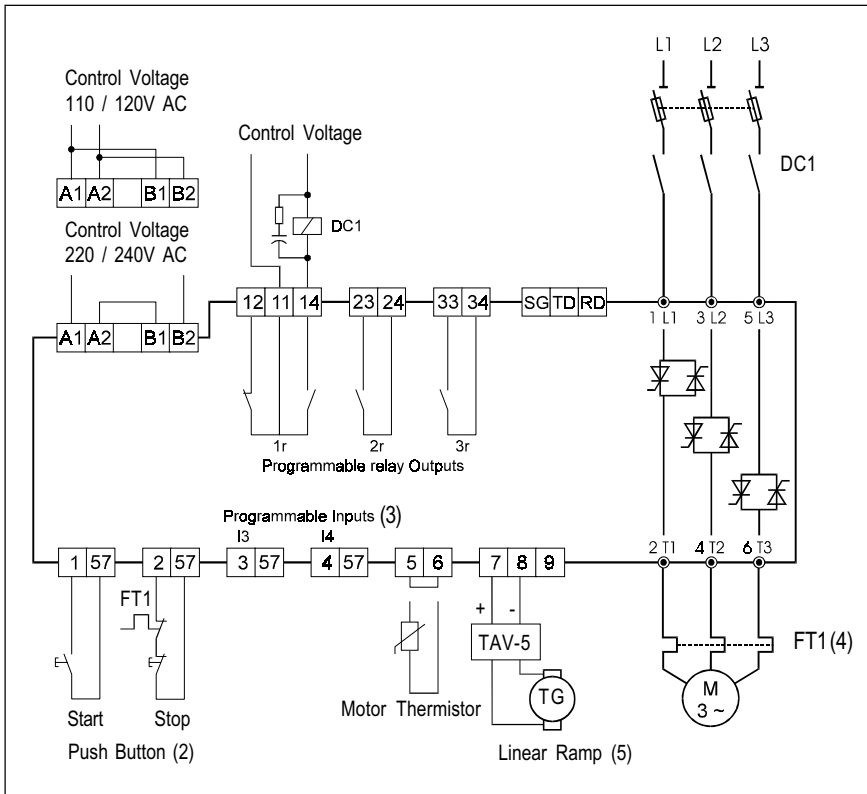

REMARKS:

- (1) The line contactor DC1, is not required to perform operation to the motor.
Be aware however that DC1 provides galvanic isolation from the mains increasing the safety.
- (2) In this example, Start and Stop command is effected by push-buttons. Permanent command is allowed as well, wiring 1, 2 and 57 terminals as shown in page 3-3.
- (3) The output relays allow for direct action on contactors according ratings specified in page 3-2 of this manual.
- (4) The ASTAT Plus is performed with an electronic motor overload protection, which may be enough in the most of the applications.
You should use an external overload protection if required by local rules or to protect the motor against current imbalance.
- (5) Linear ramp provided by "Dxxx" function. A tacho generator must be used as feedback. Details given bellow.

Linear ramp function. Programming steps

1. The linear ramp function may be enabled by setting "Dxxx" to ON. In this case, linear ramp independent of a wide load range is allowed.
This function needs the speed feedback provided by an external tacho generator. Check section 4-6-2 for more details.

6. Appendix

6-2. Serial communication

The ASTAT Plus has the possibility to communicate with a host via a standard RS232C. Through this serial communication, the ASTAT can be started, stopped, programmed and checked.

Request from the host to the ASTAT and response from the ASTAT to the host are a series of bytes in ASCII code sequentially transmitted.

6.2.1.- RS-232 connection

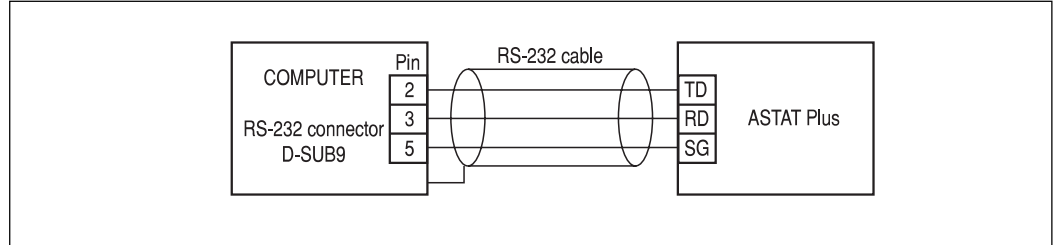

6.2.2.-Data transmission format

To write data into a parameter, the format command is the following:

Request from host :	Wxxxxyy
Response from the ASTAT :	Wxxxxyy

where 'xxx' (3 bytes needed) is the parameter number, and 'yyy' (3 bytes needed) is the value to write into the parameter.

Note: the parameters modification is not allowed while the motor is operating.

To read a parameter, the format command is the following:

Request from host :	Rxxx
Response from the ASTAT :	Rxxxxyyy

where 'xxx' (3 bytes needed) is the parameter number, and 'yyyyy' (5 bytes response) is the value of the parameter.

Examples:

- to start the unit, the command will be: **W060000**
- to stop the unit, the command will be: **W060001**
- to set the acceleration ramp time to 35sec., the command will be: **W005035**
- to know which overload curve is selected, the command will be: **R016** ;
 (if for instance the response is **R01600004**, this means that the overload curve selected is IEC class 10).

The Table A provides a complete reference as for the parameters that can be controlled by the serial interface.

Parameter number	Parameter name	Function	Read/Write (R / W)	Range	Comments
000	Status	Soft starter status	R/-	0 - 14	0: ON 1: STOP 2: LOCK 3: Alarm (errors) 4: PULS 5: RAMP 6: FULL 7: SAVE 8: SOFT 9: DCBK 10: FULL (override) 11: Not used 12: INCH 13: TACH 14: PUMP
001	M	Motor current (%N or Amps, depending on UF parameter)	R/-		
002	N	Nominal motor current (% Unit current)	R/W	40-120	
003	L	Limit current (% In)	R/W	100-700	
004	T	Starting torque (% DOL torque)	R/W	10-90	
005	a	Acceleration ramp time (sec)	R/W	1-99	
006	d	Deceleration ramp time (sec)	R/W	1-120	

6. Appendix

6-2. Serial communication

Parameter number	Parameter name	Function	Read/Write (R / W)	Range	Comments
007	p	Kick start time (msec)	R/W	0-999	
008	b	DC brake time (sec)	R/W	0-99	
009	l	DC brake current (% In)	R/W	50-250	
010	S	Soft stop control	R/W	0-3	0: OFF 1: ON 2: I3 3: I4
011	C	Pump control	R/W	0-3	0: OFF 1: ON 2: I3 3: I4
012	P	Kick start control	R/W	0-3	0: OFF 1: ON 2: I3 3: I4
013	F	Override	R/W	0-3	0: OFF 1: ON 2: I3 3: I4
014	B	DC brake control	R/W	0-6	0: OFF 1: ON 2: I3 3: I4 4: PON 5: PI3 6: PI4
015	LK	Lockout (sec)	R/W	0-45	
016	o	Overload trip curve	R/W	0-5	0: OFF 1: N1 2: N2 3: N3 4: C1 5: C2
019	R	Read EEPROM	-/W	1	
021	v	Software version	R/-	x x x	v x x x
024	1r	Programmable relay 11-12-14	R/W	22-30	See programmable relays functions in page xx
025	2r	Programmable relay 23-24	R/W	20,22-30	
026	3r	Programmable relay 33-34	R/W	21-30	
027	OC	Overcurrent (%N)	R/W	0-50	0: OFF
028	oc	Overcurrent time (sec)	R/W	0-99	
029	r	Reverse slow speed	R/W	0-3	0: OFF 1: ON 2: I3 3: I4
030	Y	Retry attemps	R/W	0-4	
031	y	Retry time (sec)	R/W	1-99	
032	UV	Undervoltage (%U)	R/W	0-50	0: OFF
033	uv	Undervoltage time (sec)	R/W	0-99	
034	OV	Overvoltage (%U)	R/W	0-30	0: OFF
035	ov	Overvoltage time (sec)	R/W	0-99	
036	UC	Undercurrent (%N)	R/W	0-99	0: OFF
037	uc	Undercurrent time (sec)	R/W	0-99	
038	PF	Power factor (%)	R/-	00-99	
039	U	Nominal voltage (volt)	R/W	100-500	
040	V	Line voltage (volt)	R/-		
041	w	Power (KW*10)	R/-		

6. Appendix

6-2. Serial communication

Parameter number	Parameter name	Function	Read/Write (R / W)	Range	Comments
042	X	Local/remote control		0-3	0: OFF 1: ON 2: I3 3: I4
043	D	Linear ramp control	R/W	0-3	0: OFF 1: ON 2: I3 3: I4
044	J	Slow speed control	R/W	0-2	0: OFF 1: I3 2: I4
045	j	Slow speed type	R/W	0-1	0: HI 1: LO
046	2a	Secondary acceleration ramp time (sec)	R/W	1-99	
047	2d	Secondary deceleration ramp time (sec)	R/W	1-99	
048	A	Dual ramp selection	R/W	0-3	0: OFF 1: ON 2: I3 3: I4
049	UF	Unit frame	R/W	0-16	0: not defined 1 to 16: F to X frames
050	E	Elapsed time (hours)	R/-		
052	Q	Recall factory settings	-/W	1	
053	2T	Secondary starting torque (%DOL torque)	R/W	10-90	
056	z	Bypass function	R/W	0-3	0: OFF 1: ON 2: I3 3: I4
058	f	Service factor (%N)	R/W	100-130	
060	RUN/STOP	RUN/STOP order	-/W		0: RUN 1: STOP
065	e0xx	error e0	R/-		xx: error code
066	e1xx	error e1	R/-		xx: error code
067	e2xx	error e2	R/-		xx: error code
068	e3xx	error e3	R/-		xx: error code

6. Appendix

6-3. Dimensions

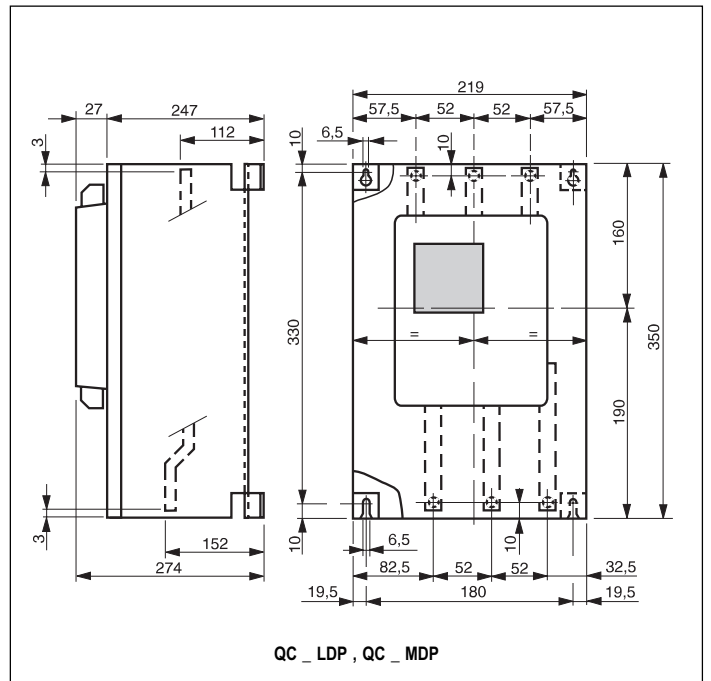
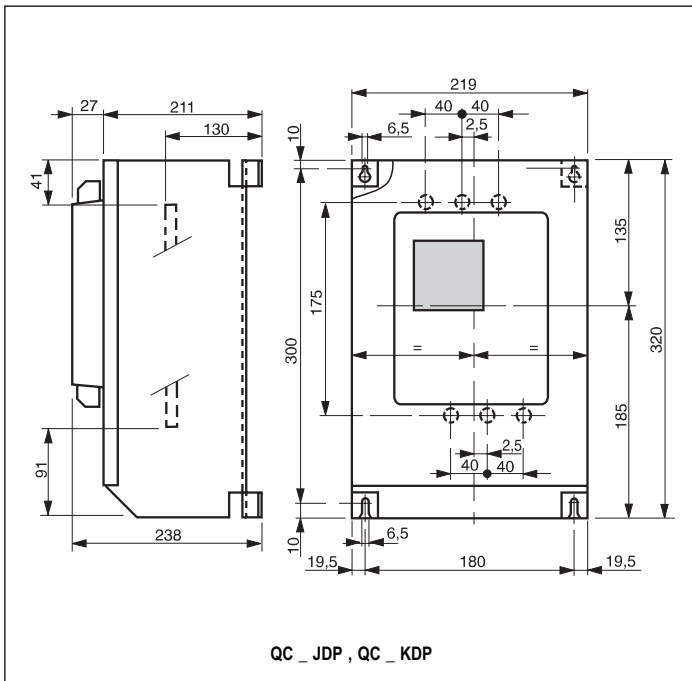
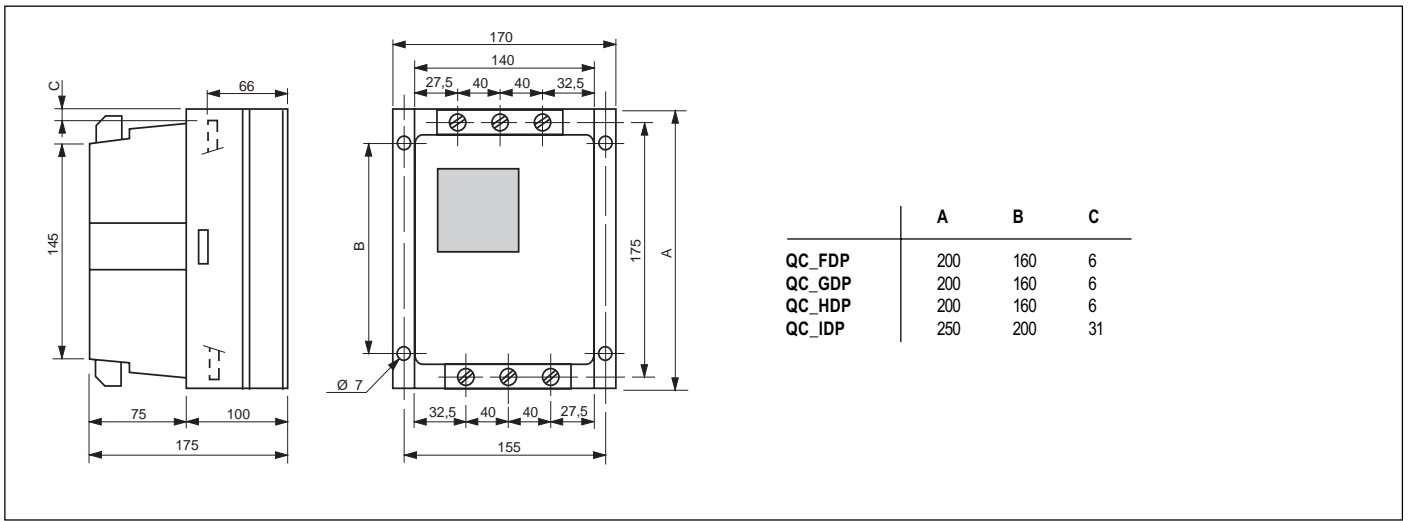

6. Appendix

6-3. Dimensions

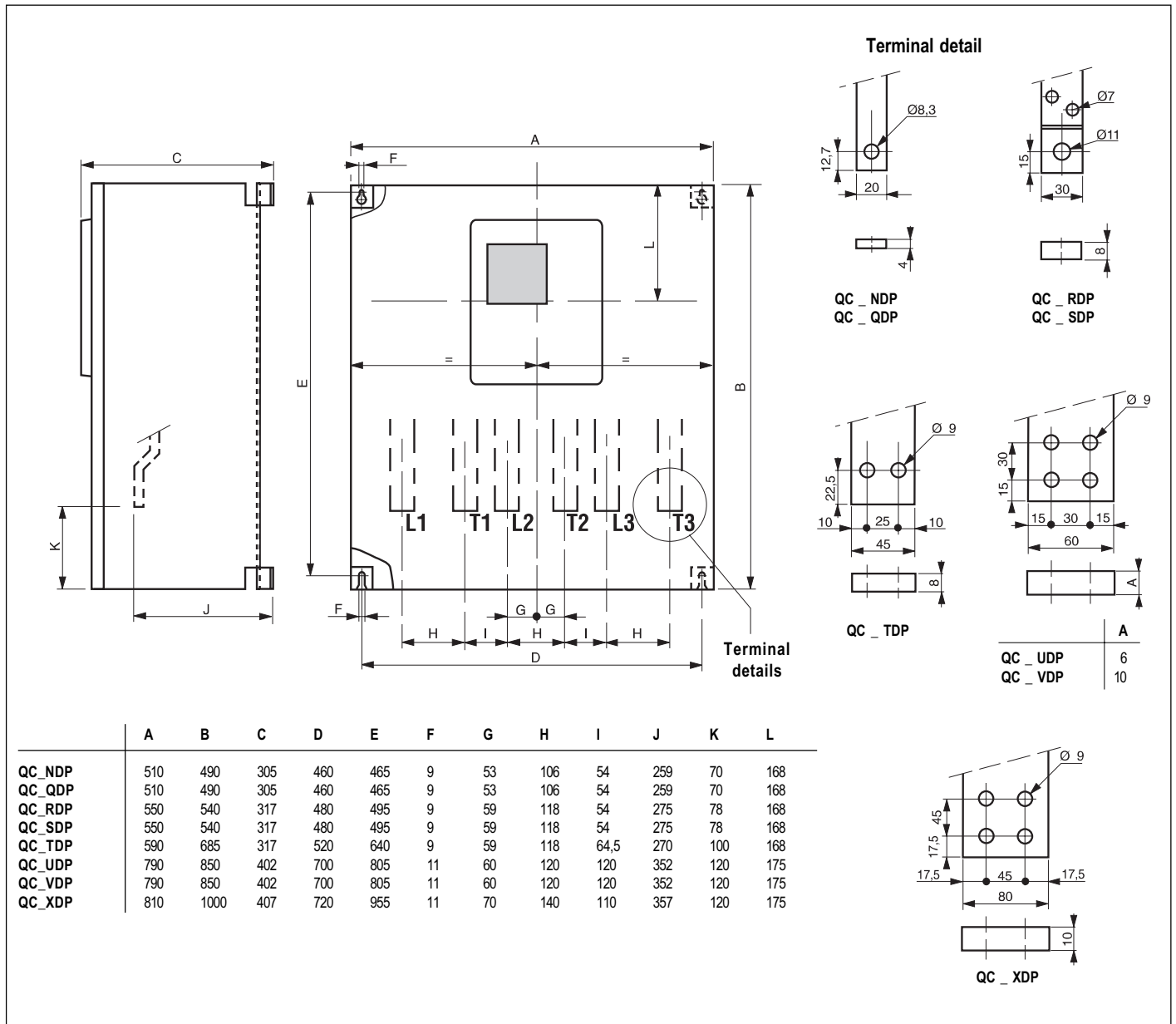

6-4. P.C.B. 's

